



Johnson Controls - Hitachi Wanbao Air Conditioning (Guangzhou)Co., Ltd.
江森自控日立万宝空调(广州)有限公司

Address: No. 1108 ChengAo East road, CongHua city,
Guangzhou, China

Telephone hotline: 400-163-1108

Official Website: <http://www.jci-hitachi.com/ga>

节能典范 · 值得信赖



CRAA质量认证



体系认证
CNAS C146-E CNAS C146-Q



环境管理体系认证
ISO14001



体系认证
CNAS C146-S



AHRI认证



质量安全

江森自控日立万宝空调(广州)有限公司相关产品已获得上述认证

江森自控日立万宝空调(广州)有限公司保留产品资料修改更新的权利，
恕不另行通知，此举有助日立公司随时把最新的科技创意带给客户采用。
具体产品性能由双方在合同中约定，本样本仅供参考。



扫一扫 · 欢迎关注

Printed in China No.JCH-GA-02-230718

HITACHI

K-VG Series/ permanent magnet synchrony

HITACHI CENTRAL AIR-CONDITIONING UNITS

Cooling capacity range:300-1100RT

Cooling & Heating





Hitachi K-VG series efficient direct-drive centrifugal chiller

Hitachi VG series efficient direct-drive centrifugal chiller is independently developed and manufactured by Hitachi, gathering advanced technology achievements of Hitachi central air conditioning research and development cooling capacity range of 300-1100RT, using R513A environmental protection refrigerant, the application of single-axis direct drive double-stage impeller technology, high-speed permanent magnet synchronous frequency conversion motor, high anti-surge frequency conversion control technology. Compared with the fixed-frequency centrifugal chiller, the overall efficiency of the unit is increased by more than 35%. The unit has the characteristics of high efficiency and energy saving, safe and reliable, stable operation, strong adaptability, etc. It can be widely used in large office buildings, hospitals, schools, shopping malls and process processes, and can directly replace the unit for energy saving transformation of the existing air conditioning system. The whole series of products have passed the certification of China Energy efficiency Certification body and obtained the certification of China Energy Saving Products.



Description of model

HC	—	**	K20D	600	G	*	VG	—	**	—	**	—	**
①		②	③	④	⑤	⑥	⑦		⑧		⑨		⑩
Number	Code description											Options	
①	High Pressure Refrigerant Centrifugal Chiller											—	
②	Refrigerant Code											Default: R513A	
③	Compressor Model											Three-Phase Asynchronous Compressor Code: K10D、K20D、K25D、K30D PMSM Compressor Code: K10M、K20M、K25M、K30M	
④	Rated Cooling Capacity (RT)											—	
⑤	Heat Exchanger Code											GX: Standard Series; GF: Efficient Series	
⑥	Airborne Code											Default: Not Airborne; U: Airborne	
⑦	Product Series Number											VG: Oil System Direct-drive Inverter Series	
⑧	Application Product Code											Default: Standard Application; D: Dual-mode Application; SC: With Subcooler Application	
⑨	Evaporator/Condenser Code											Default: Standard Product; **: Special Products	
⑩	Motor Code											Default: Standard Product; **: Special Products	

Unit structure

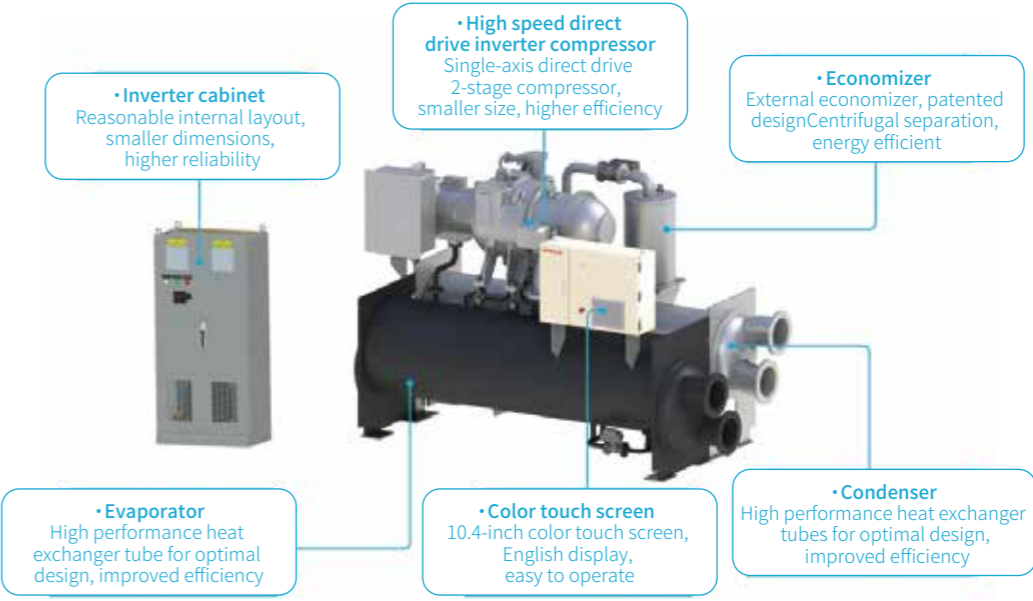

Product characteristics



Ozone layer protection

Use R513A refrigerant with 0 ODP, low GWP and no flammability.

The destruction of the stratospheric ozone layer will pose a great threat to the survival of mankind. Chlorofluorocarbons in the stratosphere break down when exposed to ultraviolet light, releasing chlorine atoms, which combine with oxygen atoms in the ozone layer and destroy the ozone layer. In R513A, since it does not contain chlorine atom, it does not destroy the ozone layer in the atmosphere.

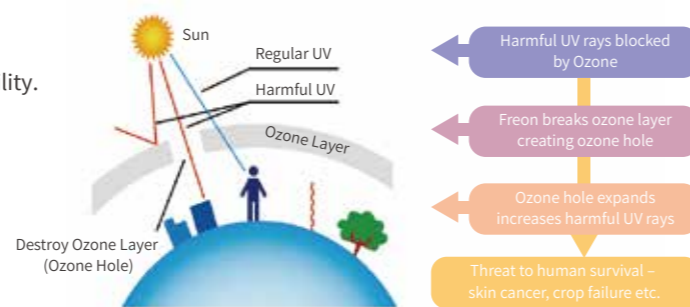

- 2-stage compression cycle
- Centrifugal economizer
- High-speed motor direct drive
- Permanent magnet synchronous inverter motor

Part load highest COP **23.05**
(HC-K20M600GFVG)

IPLV.IP (AHRI 550/590) **10.74**
(HC-K20M600GFVG)

Shift from focus on rated COP to focus on year-around overall energy efficiency

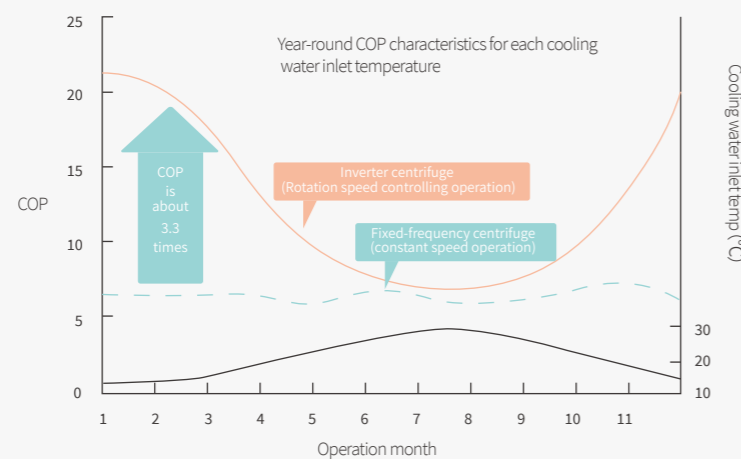

At low cooling water temperature, the partial load performance is greatly improved

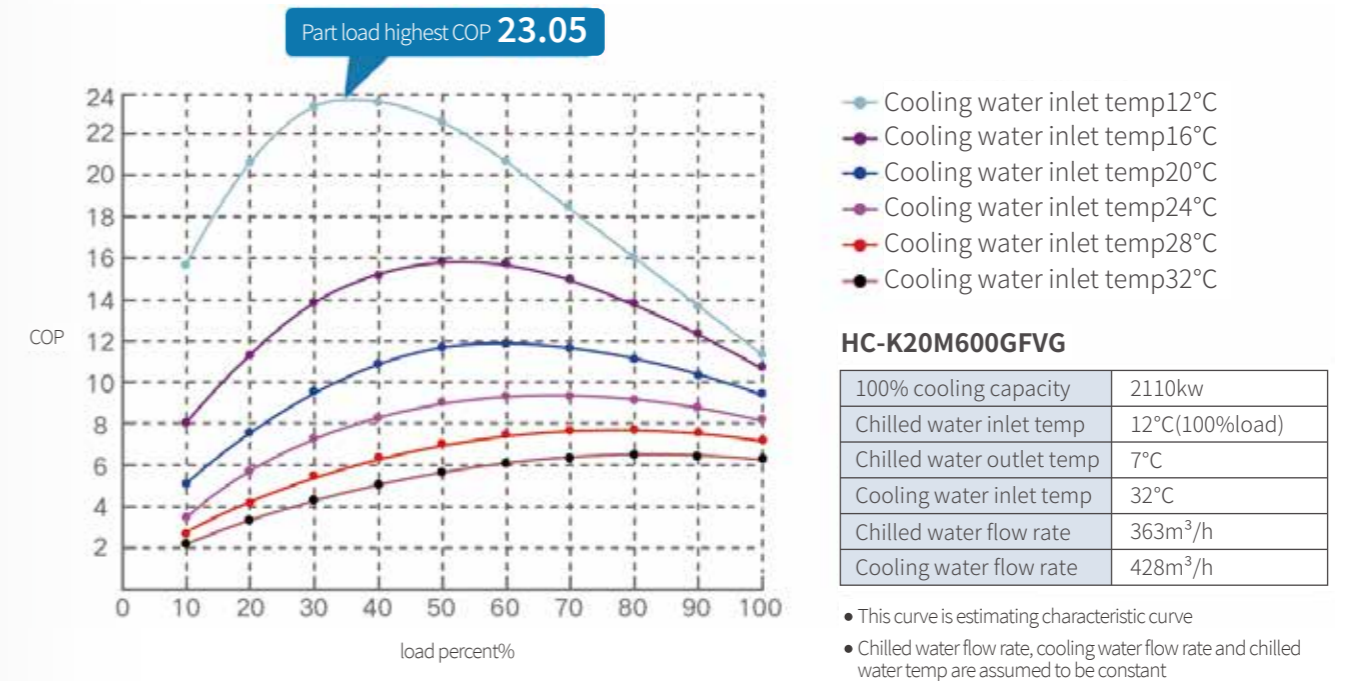

ECO mode, the unit operation efficiency is higher

In the transition season, winter and other refrigeration load reduction, such as allowing the chilled water outlet temperature higher than the rated temperature, can switch the "ECO" mode, the chilled water outlet temperature control to the chilled water inlet temperature control, to improve the efficiency of the centrifugal unit.

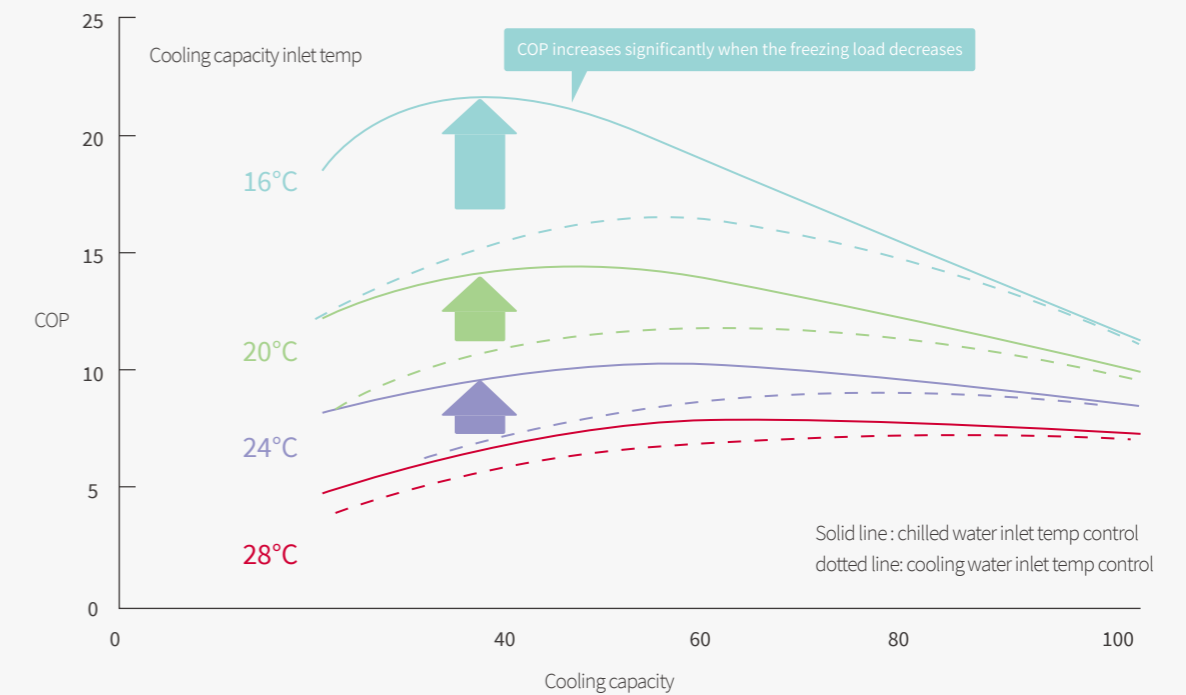

Product characteristics



2-stage compression efficient freezing cycle

Hitachi centrifugal chillers began to develop and apply two-stage compression technology in 1996 and has more than 20 years of design experience.

Two-stage compression has the following advantages over single-stage compression:

- Two-stage compression can provide a larger pressure ratio, obtain a higher refrigeration cycle efficiency, and expand the compressor application range, reduce the compressor under low load surge risk, so that the unit can still operate safely and stably.
- The use of multi-stage compression unique intermediate economizer, on the one hand to improve the refrigerant supercooling degree, increase the cooling capacity; On the other hand, the gas transmission of the first stage impeller is reduced, and the power consumption of the unit is reduced.
- Two-stage compression can reduce the speed of the compressor motor, improve the reliability of operation, increase the service life of the bearing, the unit vibration is small, low noise.

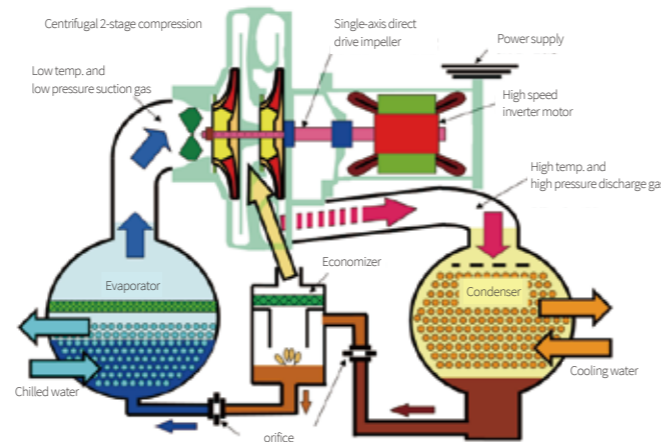

Centrifugal Economizer

· Hitachi patented centrifugal economizer is used to improve the performance of gas-liquid separation, improve the capacity and efficiency of the refrigerant system as a whole, and extend the service life of the unit.

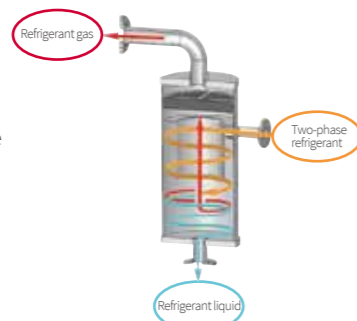

Single-axis direct drive two-stage impeller technology

- Adopt high-speed inverter motor single-axis direct drive two-stage impeller, compared with conventional gear compressor, reduce the mechanical loss caused by gear transmission, with higher energy efficiency.
- Direct drive, simple transmission system, high power density of high-speed variable frequency motor, compact size, compressor volume and weight is only 40% of the same cooling capacity of conventional compressor.
- Cancel the speed increasing gear, reduce the moving parts, the main vulnerable and consumable parts are reduced by 66% than the conventional compressor, at the same time, there is no high-frequency noise of the gear, the compressor operation noise is reduced.

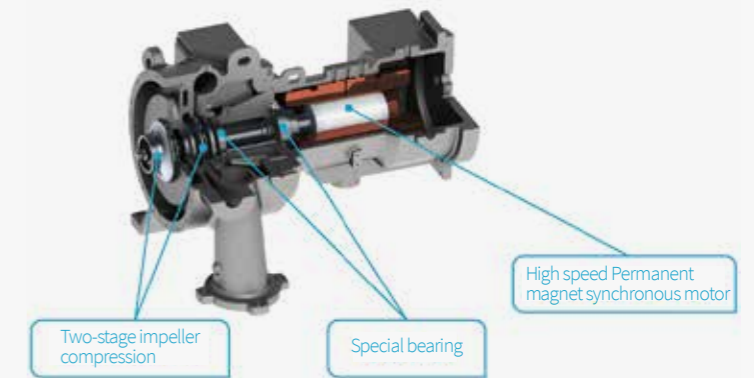

High speed permanent magnet synchronous inverter motor

Compared with asynchronous motor, permanent magnet synchronous motor has obvious advantages. It has high efficiency, especially the improvement of partial load efficiency, high power factor, small size, light weight, low working temperature rise, which better improves the quality factor of the power grid and saves the investment of the power grid.

- The high-power high speed permanent magnet synchronous motor independently developed by Hitachi for centrifugal compressors is used, with a power range of 250kW ~ 560kW and a speed range of 8500 rpm ~ 13085 rpm.
- High-speed permanent magnet synchronous motor, eliminate the excitation system loss, improve the motor efficiency, motor efficiency is more than 96%, the highest efficiency up to 98%, greatly improve the unit full load and partial load operation energy efficiency.

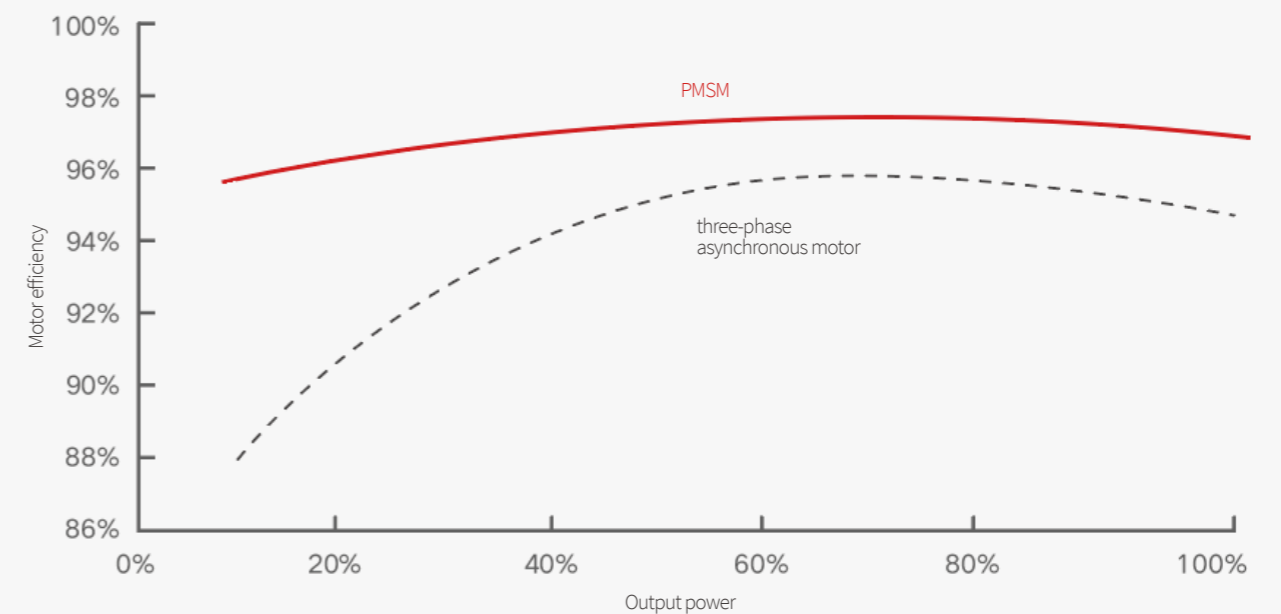

- The motor adopts ring refrigerant cooling technology to fully cool the stator and rotor of the motor, and the motor temperature field is uniform. The motor adopts H-class insulation design, and the temperature protection device is embedded inside the motor winding group, which always ensures the safe, efficient and stable operation of the motor.

Product characteristics

Mechanical characteristics



Fluid design for high-performance centrifugal compressor

The compressor adopts a new high efficiency closed impeller designed for R1234ZE refrigerant based on the theory of 3d-flow. The impeller adopts a wing-shaped three-dimensional structure with low flow loss to achieve high efficiency and reliability in a wider range of fields. The impeller is made of special aluminum alloy with high strength, and the ideal fluid shape is made by vacuum precision casting. At the same time, the strength analysis, coordinate detection, dynamic balance test and over-speed test of the impeller structure are carried out to ensure the reliable operation of the impeller at high speed.

With vane diffuser design can effectively convert high-speed gas into high static pressure gas, and achieve excellent pressure recovery. At the same time, through software simulation calculation, the blade is machined into the most ideal shape by CNC machine tool, which makes the operation range of the unit wider, the surge margin wider and the unit efficiency higher.

The impeller and the main shaft are connected with a free spline structure, which avoids the problem of local stress concentration caused by key connection, improves the low cycle fatigue strength of the compressor, and ensures the reliability and smoothness of the unit operation.

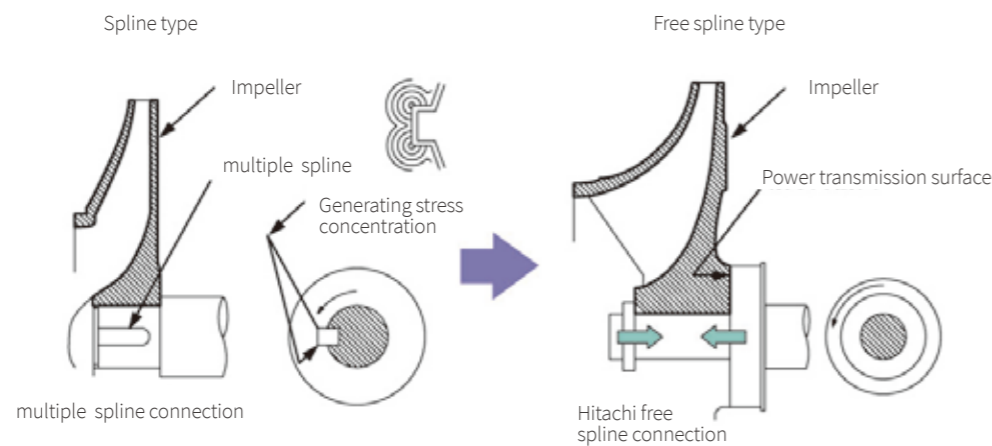

The fluid inside the compressor is reasonably designed to reduce the flow noise; By adopting two-stage compression, the rotation speed of the compressor motor is reduced, especially the low noise in the high frequency area is realized.

The semi-closed motor with liquid refrigerant spray cooling not only fully reduces the risk of refrigerant and lubricating oil leakage, but also controls the heat dissipation of the unit very well, saving the initial investment and operating costs of increasing the cooling device in the machine room.

High anti-surge frequency conversion control technology

Due to the high ambient temperature of summer in Japan, its industrial standard JIS puts forward high requirements for the stable operation of the unit in a high temperature environment. Hitachi centrifugal chiller strictly comply with Japanese JIS standards, the use of two-stage wing-like three-dimensional high efficiency impeller and blade diffuser can operate stably even when the cooling load is small and the cooling water temperature is high, to prevent the occurrence of surge and ensure high reliability of operation. It can realize stable operation in the cooling water inlet temperature range of 12 ~ 34 °C and realize stepless adjustment of 10 ~ 100% load.

Cooling water inlet temperature under different loads:

Load	Hitachi Standard	AHRI Standard	GB Standard
100%	32°C	29.4°C	30°C
75%	30.75°C	23.9°C	26°C
50%	29.5°C	18.3°C	23°C
25%	28.25°C	18.3°C	19°C
0%	27°C	18.3°C	19°C

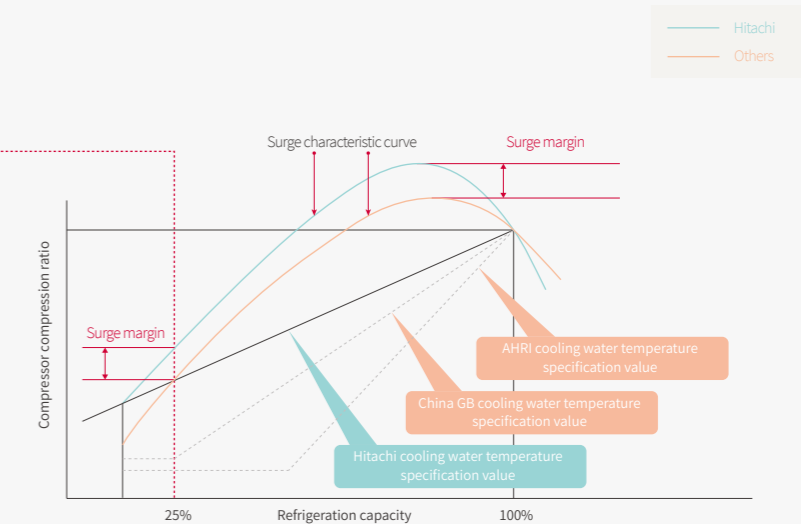

Adopt high-speed frequency conversion motor with wider frequency range, so that the unit priority through changing speed to achieve load change, thereby reducing the guide vane throttling loss to improve the unit performance.

Speed changes through pressure ratio to avoid unit surge caused by pollution of the heat transfer tube and escort the unit through strict surge detection and avoidance functions.

High performance heat exchanger

Adopt high-performance heat transfer tube designed for centrifugal chiller, the overall rational arrangement of the tube group, improve the performance of the heat exchanger.

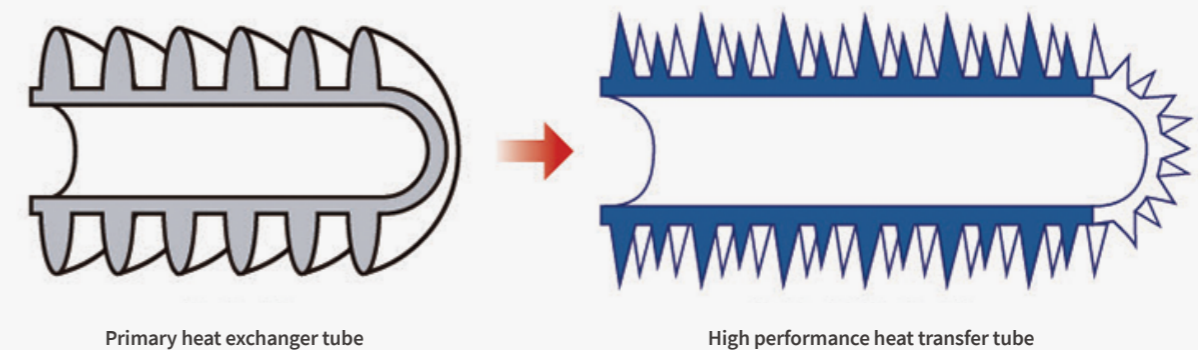

Product characteristics

Reliable oil supply system

Adopt Hitachi oil pump specially developed for centrifugal chiller, which has good sealing performance, by using lubricating oil cooling, reliable and stable operation.

Lubricating oil is cooled by refrigerant through plate heat exchanger, without cooling water pipe, and reliability is greatly enhanced.

When the compressor speed is low, the bearing friction heat is reduced, and the oil temperature of the unit is not too low by increasing the oil temperature control of the shaft bearing at different speeds.

The oil filter before and after the pipe distribution system is equipped with a standard stop valve, easy to clean and replace the filter element.

Before the unit starts, the oil pump starts in advance for bearing lubrication. The oil pump continues to operate during the unit operation and the inertia operation phase of shutdown. In the case of abnormal power failure, the gravity type emergency oil supply device can ensure the lubrication of the bearing, and no abnormal wear and damage will occur to ensure the safety of the unit's operation.

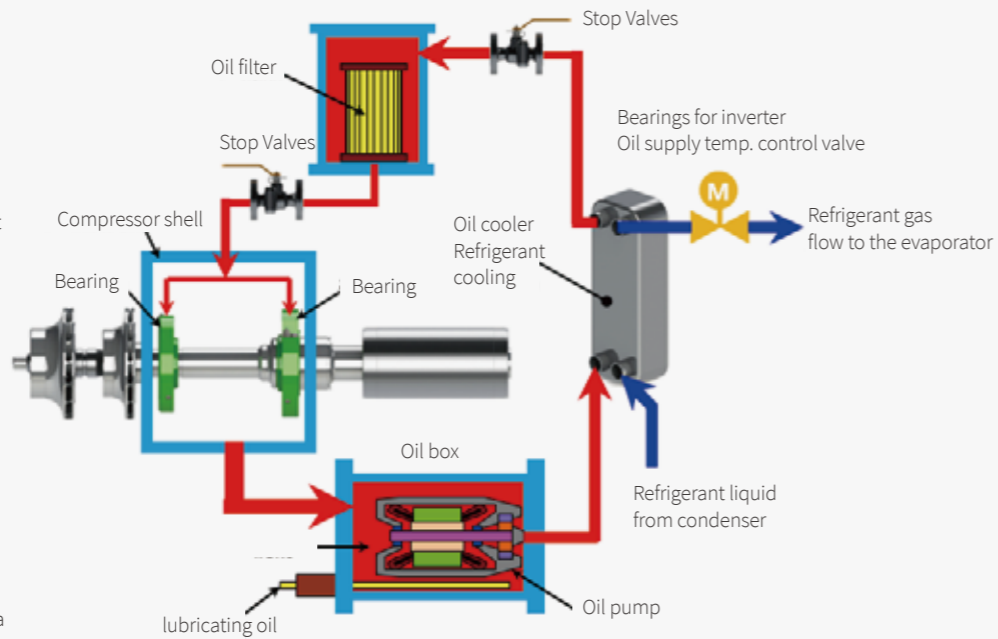

Fully automatic oil recovery system

Hitachi patented automatic injection back oil technology, which adopts oil pump exhaust as the injection power source, oil pressure is stable, oil recovery capacity will not be reduced with the change of unit working conditions, automatically and timely heat exchanger stored lubricating oil back to the tank, to avoid the lubricating oil into the refrigerant system caused by the heat transfer efficiency reduction; At the same time, no manual operation is required to reduce the daily maintenance and management costs of users.

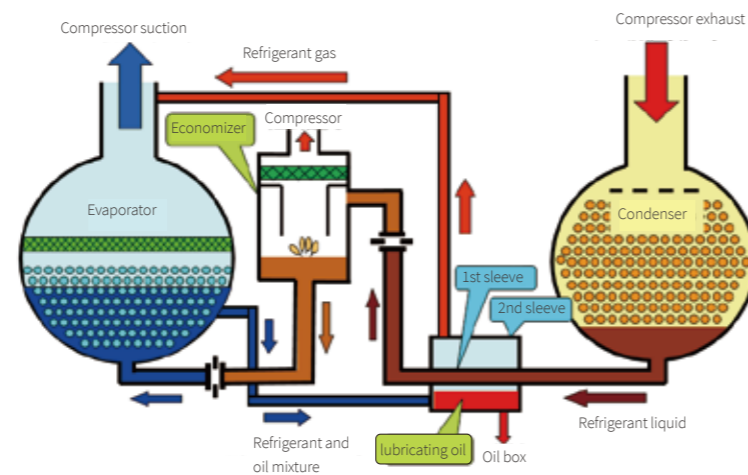

Color touch screen, English display, easy to operate

- The control center is completely composed of 10.4-inch color LCD touch display (LCD), which is clean and clear in appearance.
- Colorful touch screen, improve the convenience of recognition, simple and fast operation.
- Centralized display of the unit's simple process and various operating information.
- Centralized control of various Settings and states of the unit.
- Set three levels of access according to manufacturer Settings, customer service maintenance and different needs of users.



Display Information

- Display each operating status and operating data
- Display the trend chart in operation
- Display the past trend data (updated every minute)
- Display and save the fault and alarm history
- Display the corresponding guidance when the fault occurs

Show running status

- Main motor stopping
- Load limiting
- Oil pump stopping limiting
- Evaporation pressure
- Oil heater stopping
- Condensing pressure limiting
- ECO mode
- Restart limiting
- Power saving mode
- Low load stopping
- Bypass valve
- Power failure stopping



Display analog data

- Chilled water inlet temperature
- Cooling water inlet temperature
- Oil supply temperature
- Evaporation temperature
- CLTD
- ELTD
- Oil supply pressure
- Running current
- Chilled water outlet temperature
- Cooling water outlet temperature
- Tank temperature
- Condensing temperature
- Evaporation pressure
- Condensing pressure
- Operating frequency
- Capacity valve opening



Product characteristics

Fault and alarm information

- High temperature of main motor
- Chilled water over cooling
- Oil pump overload
- Chilled water/cooling water chain abnormal
- Communication abnormal
- Sensor abnormal
- Evaporator low pressure
- High oil supply temperature
- Frequency converter fault
- Low oil supply pressure
- Starting time out
- Sensor abnormal
- Frequency abnormal
- Battery abnormal
- Chilled water cut off
- Frequency converter abnormal
- Condenser high pressure
- Low tank temperature
- Cooling water cut off (optional)
- Emergency stop
- Abnormal economizer
- Capacity control valve potential abnormal

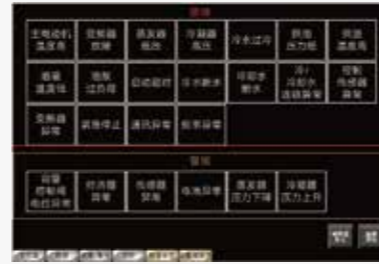

Remote Communication function

Through the RS485 interface, using the same communication format as the upper communication MODBUS RTU, to communicate with other equipment, real-time data acquisition and monitoring of the unit, users can form their own group control system according to actual needs. The user can control the start and stop of the unit by remote signal. And set the temperature or load limit value of the Chilled water outlet of the chiller by input DC4 ~ 20mA current signal remotely according to their own needs, and the load limit range is 5% ~ 100%.

Remote signal output

- Chiller operation signal output
- Main motor running signal output
- Restart limit signal output
- Remote/local signal output alarm
- Chilled water pump interlock signal output
- Main motor current analog signal output (DC4 ~ 20mA)
- Condensing pressure analog signal output (DC4 ~ 20mA)
- Capacity valve opening analog signal output (DC4 ~ 20mA)
- Fault signal output
- Low load stop signal output
- Cooling pump interlock signal output

Options

Evaporator/condenser water side pressure

Standard unit design pressure 1.0MPa, there are 1.6MPa, 2.0MPa specifications and special requirements specifications for choice.

Refrigerant isolation valve

Allows the refrigerant to be isolated and stored in the condenser during maintenance, eliminating the need to transfer the refrigerant to another container.

Spring isolator

The standard unit is equipped with high elastic rubber shock absorber gaskets. If there are special application requirements, spring shock absorber can be selected to further slow down the vibration transmission of the unit to the bearing surface.

Disassemble and knockdown shipment

If the equipment handling space is limited and the whole chiller is not allowed to be hoisted, the chiller can be disassembled into several large parts (compressors, heat exchangers, electric control boxes, economizers) and then hoisted to a smaller space.

Marine water tank

Marine water chamber tank makes it very convenient to clean the heat exchanger copper pipe without removing the water pipe.





·K-VG Series:

300~1100RT Recommended selection specification (Power Source AC 380V/50Hz/3φ/3W, Inverter starter, R513A)

Type	Cooling		Input power	Full load efficiency	COP	Rated Current	Evaporator				Condenser				Overall Dimension			Shipping Weight	Operating Weight	Ref.Amount (Initial charge)
	Unit	USRT					kW	kW/RT	A	Flow rate	Pressure drop	Pipe Diameter	Pass	Flow rate	Pressure drop	Pipe Diameter	Pass			
HC-K10M300GFVG	300	1055	179.3	0.598	5.884	291	181.4	78.3	150	—	211.1	64.2	200	—	4650	1850	2300	6.8	8.3	600
HC-K10M400GFVG	400	1407	238.7	0.597	5.894	387	241.9	83.3	200	—	281.4	67.6	200	—	4650	1850	2300	7.0	8.6	600
HC-K20M500GFVG	500	1758	286.9	0.574	6.128	464	302.4	74.6	200	—	349.8	60.1	250	—	4650	1950	2450	8.2	10.0	700
HC-K20M600GFVG	600	2110	343.7	0.573	6.139	556	362.9	78.6	250	—	419.7	65.4	250	—	4650	1950	2450	8.4	10.3	700
HC-K25M700GFVG	700	2461	411.6	0.588	5.979	666	423.4	81.1	250	2	491.4	68.6	250	2	4700	2350	2750	10.6	12.7	800
HC-K25M800GFVG	800	2813	469.6	0.587	5.990	760	483.8	83.9	250	—	561.5	70.8	300	—	4700	2350	2750	10.8	13.0	850
HC-K30M900GFVG	900	3165	526.6	0.585	6.010	852	544.3	85.3	300	—	631.4	71.1	300	—	4700	2450	2850	12.2	14.8	900
HC-K30M1000GFVG	1000	3516	584.2	0.584	6.018	945	604.8	87.0	300	—	701.4	72.5	350	—	4700	2450	2850	12.5	15.2	900
HC-K30M1100GFVG	1100	3868	641.5	0.583	6.030	1037	665.3	91.1	300	—	771.3	80.3	350	—	4700	2450	2850	12.7	15.5	950

Note:

(1)Annotation : Applicable conditions: chilled water inlet/outlet temperature 12/7°C, cooling water inlet/outlet temperature 32/37°C.

(2) This table is based on normal water, so please contact us if you need to use seawater, salt water, etc.

(3) Capacity controlling range standard is 100-10%, no additional hot gas bypass is required.

(4) The operating pressure of cold water and cooling water is 1.0 MPa, if it exceeds this specification, please specify it at the time of inquiry (the maximum pressure used for the alternative is 2.0 MPa)

(5) The fouling coefficient of the water side of the evaporator is 0.018m²C/kW, and the fouling coefficient of the water side of the condenser is 0.044m²C/kW.

(6) It is the Company's consistent policy to improve our products, and the configuration is subject to change without notice.

Product installation

Unit basic installation dimensions

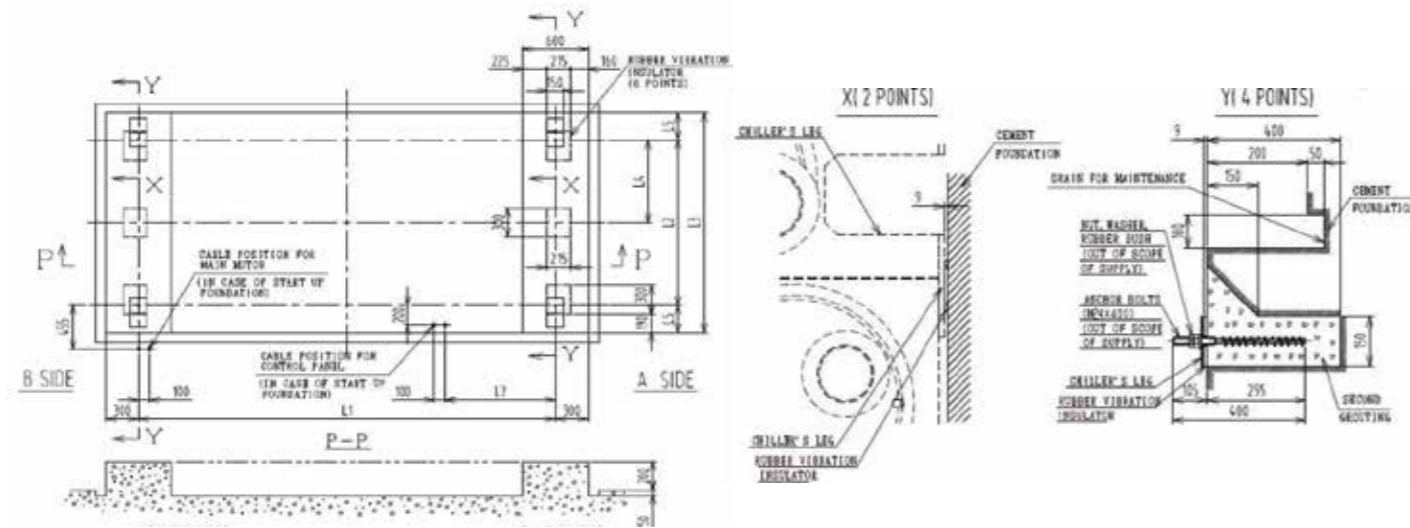

User Notice:

- Floor installation is the standard installation method of the unit, and the foundation on both sides of A and B should be able to withstand the load of the unit.
- When installing on the floor, the attached rubber vibration damping pad should be placed.
- As shown in the construction of the basic drawing, it can effectively drain water and prevent corrosion of the unit feet.
- When cleaning the heat exchange tube of the unit, it is necessary to carry out drainage treatment. So please set up drains around the unit.
- The cement foundation surface needs to be smooth and horizontal, and the horizontal error between the centers above the installation seat must be within 0.5mm every 1m. (Please prepare the level ball for adjustment)
- Cement construction for foundation and maintenance is not in the scope of our construction.
- Foundation bolts, nuts, washers will not be supplied, please prepare in advance.
- Users can choose the installation method of the unit according to the local geological conditions and the requirements of the equipment installation specifications for the equipment foundation, such as the fixing method of expansion screws proposed by the design institute and the owner.
- Please contact us if spring isolator is needed for floor installation.

·K-VG Series

Model	Unit Dimensions				
	L1	L2	L3	L4	L5
—	mm	mm	mm	mm	mm
HC-K10M300~450GFVG	3800	1303	2063	580	380
HC-K20M500~650GFVG	3800	1402	2162	650	380
HC-K25M700~850GFVG	3800	1622	2462	810	420
HC-K30M900~1100GFVG	3800	1758	2598	850	420

Unit outline and piping size

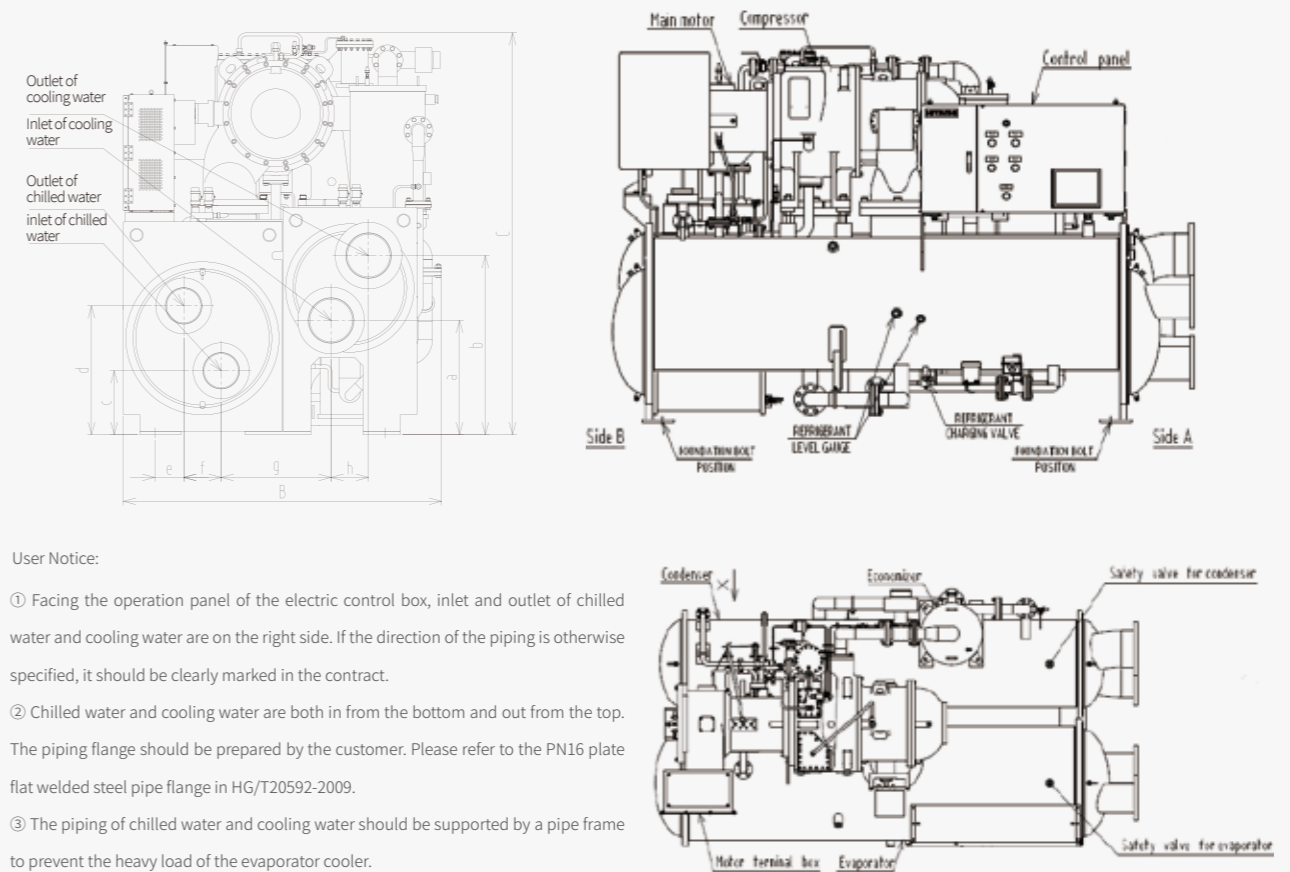

User Notice:

- Facing the operation panel of the electric control box, inlet and outlet of chilled water and cooling water are on the right side. If the direction of the piping is otherwise specified, it should be clearly marked in the contract.
- Chilled water and cooling water are both in from the bottom and out from the top. The piping flange should be prepared by the customer. Please refer to the PN16 plate flat welded steel pipe flange in HG/T20592-2009.
- The piping of chilled water and cooling water should be supported by a pipe frame to prevent the heavy load of the evaporator cooler.
- In the inlet piping side of chilled water and cooling water, please install 10-mesh filter.
- When cleaning the heat exchange tube of the unit, it is necessary to carry out drainage treatment. So please set up drains around the unit.
- Please arrange the flow adjustment of chilled water and cooling water at the outlet side of the unit.
- Install the pressure gauge and the valve for disassembling the pressure gauge within 200mm from the inlet and outlet pipe flange of the chilled water and cooling water of the chiller.

·K-VG Series

Model	Unit Dimensions			Pipe Position Dimensions								
	L	W	H	a	b	c	d	e	f	g	h	i
—	mm	mm	mm	mm	mm	mm	mm	mm	mm	mm	mm	mm
HC-K10M300~350GFVG	4650	1850	2300	671	1017	352	692	170	196	652	200	524
HC-K10M400~450GFVG	4650	1850	2300	671	1017	371.5	711.5	170	196	652	200	524
HC-K20M500~550GFVG	4650	1950	2450	693	1087	388	782	176.2	227.5	667.5	227.5	524
HC-K20M600~650GFVG	4650	1950	2450	693	1087	407	801	176.2	227.5	667.5	227.5	524
HC-K25M700~750GFVG	4700	2350	2750	843	1237	438	832	231.3	227.5	774.5	227.5	524
HC-K25M800~850GFVG	4700	2350	2750	815	1265	458	852	231.3	227.5	758.3	260	524
HC-K30M900~950GFVG	4700	2450	2850	795	1245	442.5	927.5	239	280	800	260	524
HC-K30M1000~1100GFVG	4700	2450	2850	777.5	1262.5	462	947	239	280	790	280	524

Product installation

Maintenance space

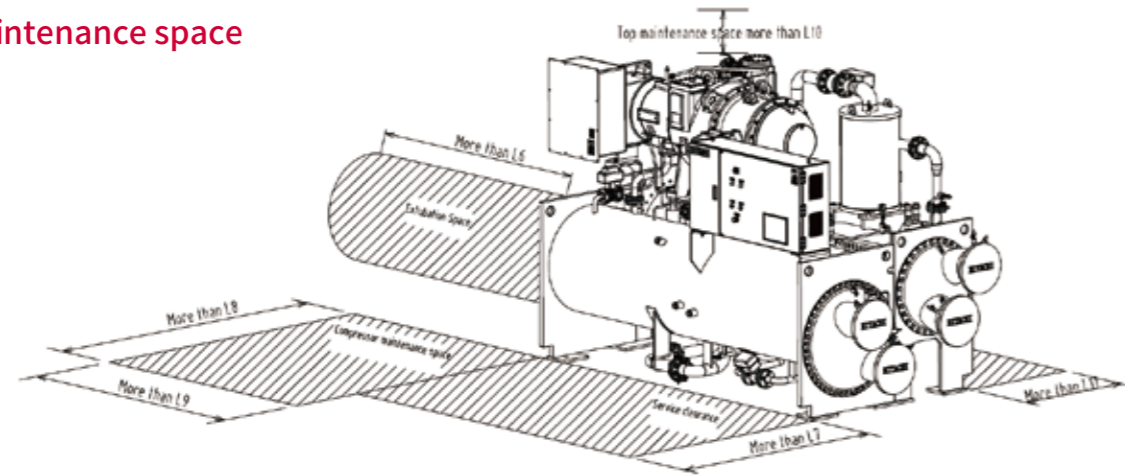

• K-VG Series

Type	Unit Maintenance Space					
	L6	L7	L8	L9	L10	L11
	mm	mm	mm	mm	mm	mm
HC-K10M300~450GFVG	4300	1500	2000	2500	850	500
HC-K20M500~650GFVG	4300	1500	2000	2500	850	500
HC-K25M700~850GFVG	4300	1500	2000	2500	850	500
HC-K30M900~1100GFVG	4300	1500	2000	2500	850	500

Inverter cabinet wiring diagram

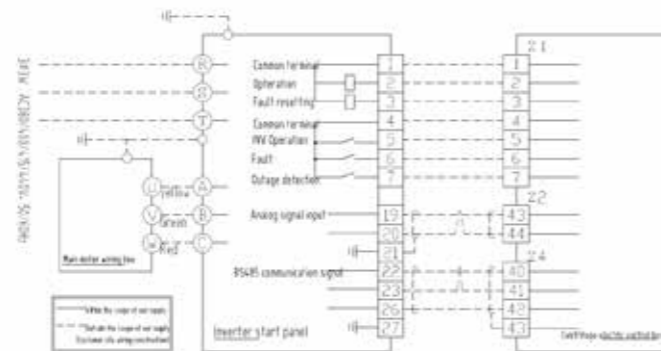

Scope of supply

Item	Standard Scope
Equipment	Chiller, Electrical control box, Inverter box, Lubrication oil, Refrigerant(first charge), Insulation
Test	delivery inspection
Coating	Chiller main unit: Anti-corrosive prime coating Electrical control box: rust-proof treatment(color: Munsell 5Y8/1 gloss) Inverter box: rust-proof treatment(color: Munsell 5Y7/1 semigloss)
Engineering	Unit commissioning, operation guidance
Setting place	Indoor setting
Exclusion	Carrying-in, Installation, Foundation construction, Wiring work, Comprehensive trial operation commissioning, Adjustment of outdoor discharge pipe for safety valve, Comprehensive trial operation and joint inspection

Operating instructions

Storage environment

Category	Contents
Ambient Temperature	Below 40°C (When the ambient temperature is lower than 0°C, water side of evaporator and condenser must release pressure and add appropriate amount of anti-freeze, or release all water)
Relative Humidity	Relative humidity in environment should be under 80%, without condensing water
Atmosphere Corrosive Gas Content	SO ₂ : ≤10mg/m ³ HCN: ≤5mg/m ³ H ₂ S: ≤5mg/m ³ Nitrogen Oxides: ≤5mg/m ³ HCL: ≤5mg/m ³ CL: <1mg/m ³
Storage	① Please store the unit in the room with ventilation facilities, do not store outdoors in direct contact with rain, water and sunlight. ② The unit must not be placed in a corrosive, flammable and explosive, or oil mist environment

Operating environment

Category	Contents
Voltage Fluctuating Range	Rated running voltage ±10%
Voltage Imbalance	≤2%
Operating Environment Temperature	3°C~40°C(Chiller plant room ambient temperature)
Relative Humidity	Relative humidity in environment should be under 80%, without condensing water
Altitude	<1000 meters(High altitude will influence the electric insulation and conductive performance of the unit, need special adjustments)
Atmosphere Corrosive Gas Content	SO ₂ : ≤10mg/m ³ HCN: ≤5mg/m ³ H ₂ S: ≤5mg/m ³ Nitrogen Oxides: ≤5mg/m ³ HCL: ≤5mg/m ³ CL: <1mg/m ³

installation

- ① The unit cannot be installed in a corrosive, flammable and explosive environment or a place with special requirements such as oil mist, otherwise it will cause the unit to fail to operate normally or shorten the service life of the unit, and even cause fire or serious injury. If installed together with heating elements such as boilers, full attention should be paid to the impact of thermal radiation
- ② Please install the unit in a well-ventilated place, because over-high temperature is the cause of electrical failure and can accelerate the corrosion of the equipment
- ③ Please choose a place with less dust, because excessive dust is also one of the causes of electrical failure
- ④ Please choose a place with good lighting, which is conducive to maintenance and inspection
- ⑤ In order to meet the needs of maintenance, overhaul and cleaning of the evaporator-condenser heat exchange tube, there must be enough space around the unit
- ⑥ To facilitate machine lifting and maintenance. The crane or boom crane should be installed, and pay attention to the machine room to have sufficient height
- ⑦ Around the unit and the whole machine room should be able to achieve complete drainage

Thermal insulation

The factory has laid a 20mm thick insulation layer on the evaporator shell (including end cover, support feet, etc.), compressor suction tube and motor shell and other main parts that need insulation. For different use environments, non-standard options of 25mm, 40mm and other thickness can be provided according to customer requirements, please specify when placing an order.

Chilled water outlet Temperature	Ambient temperature	Relative humidity	Recommended insulation thickness
°C	°C	%	mm
teo ≥ 5	10 ~ 32	RH ≤ 70	20
		70 < RH ≤ 73	25
4 ≤ teo < 5	10 ~ 32	73 < RH ≤ 38	40
		RH ≤ 73	40

Note: If the unit exceeds the above range, please contact the factory technical support to confirm the thickness of the corresponding unit insulation material.