

air

## Johnson Controls - Hitachi Air Conditioning

### ADDRESS

New Pier Takeshiba South Tower  
1-16-1, Kaigan Minato-ku, Tokyo 105-0022, JAPAN  
Tel: +81-3-6721-5567  
[www.jci-hitachi.com](http://www.jci-hitachi.com)

HITACHI. CERTIFIED QUALITY

The specifications of this catalog may change without prior notice to allow Hitachi Cooling & Heating to incorporate the latest innovations for its customers. The information contained in this catalog is merely informative. Hitachi Cooling & Heating declines any responsibility in the broadest sense, for damage, direct or indirect, arising from the use and / or interpretation of the recommendations in this catalog.

**Find the products Hitachi Cooling & Heating with the best service and conditions at your Hitachi Distributor.**

WVY-C-1910

HITACHI

# Variable Speed Water-cooled Screw Chiller

WVY SERIES

Cooling & Heating





## — INDEX

---

03 Overview

---

07 Product Features

---

10 Advanced Control

---

13 Specifications

---

16 Dimensions

---

17 Foundation Drawings

---

19 Installation

---



gettyimages®

Copyright Xinzheng. All Rights Reserved.

# OVERVIEW

Keeping pace with the times, we are constantly introducing high-quality products. The new RCUF-WVY Series with R134a refrigerant is designed to meet demanding environmental requirements – and to last well into the long term.

Since the introduction of the world's first semi-hermetic twin-screw compressor in the field of HVAC, Hitachi has never slowed its pace in delivering innovative technology to meet increasing customer needs in energy saving. The latest new high efficiency variable speed water-cooled screw chiller, the RCUF-WVY series, is equipped with the latest G type screw compressor and advanced VFD control technology. The RCUF-WVY delivers a superior performance that well exceeds the typical industry efficiency level, helping customers achieve the greatest possible value.

## UNIT STRUCTURE

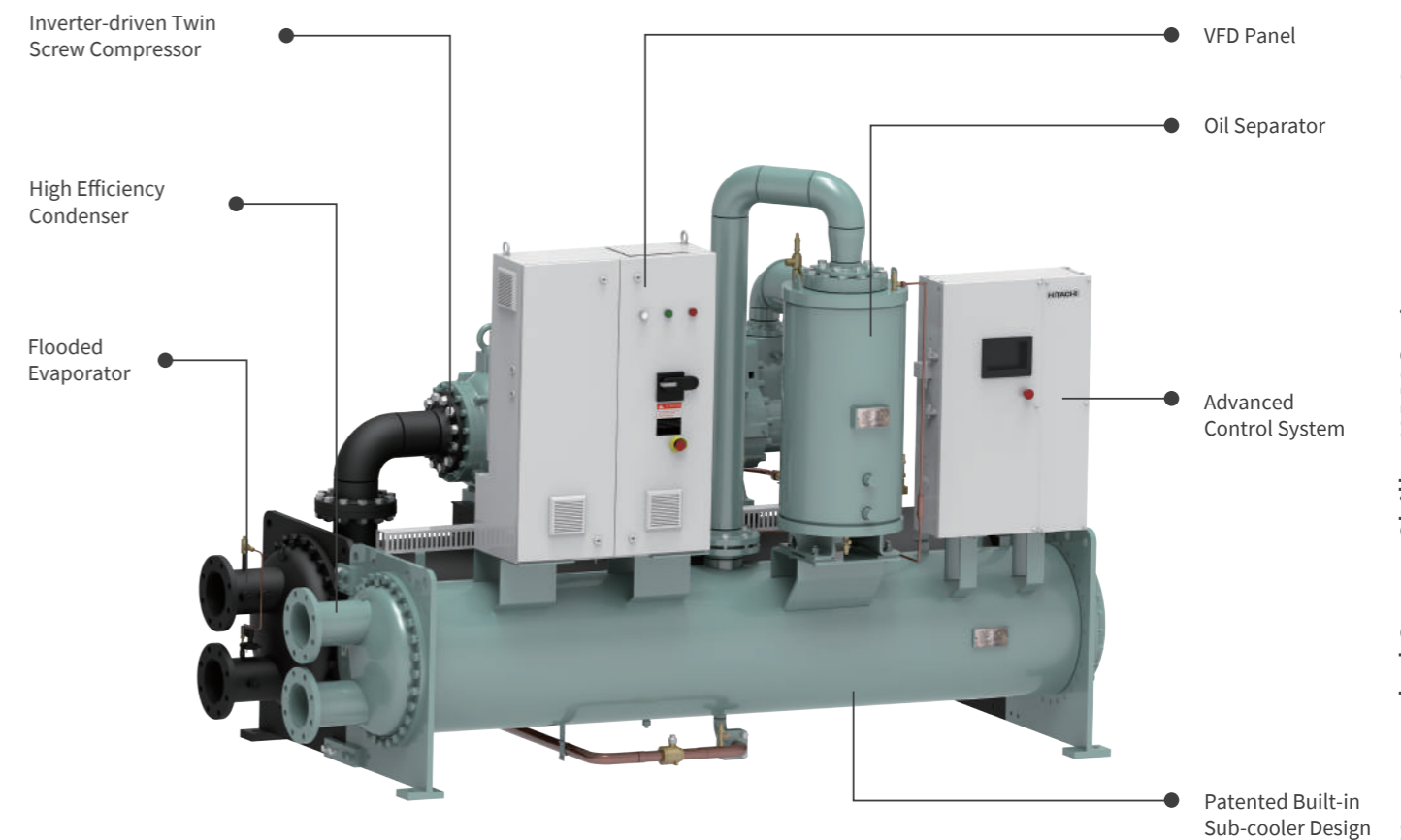

## NOMENCLATURE

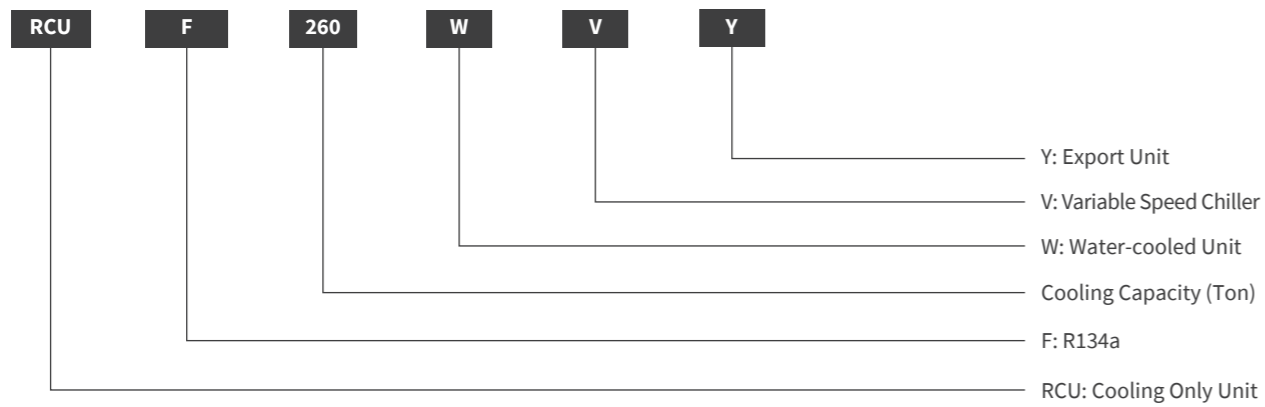

## VALUE PROPOSITION

Considering that an air conditioning system may use 30%~40% of a building's annual energy consumption, chiller efficiency really matters. During day-by-day operations, it operates up to 99% of the time in off-design conditions. Typically, operating costs will reach 8-10 times the initial chiller cost; investing in real-world efficiency is one of the fastest ways to save money when balancing your building's budget.

With advanced, unit-mounted and inverter-driven technology, the RCUF-WVY series is designed for high performance, both at full load and at part load. Its exceptional efficiency performance at part load is up to 9.93, surpassing the top GB in China and ASHRAE standards. The yearly system efficiency is around 20-30% higher than the transitional fixed speed chiller, helping customers to significantly save energy consumption, with the payback year coming in less than 2 years in most cases.

### Comfortable Cooling



OFFICE



RETAIL



HOTEL



HOSPITAL



SCHOOL/COLLEGE

### Process Cooling



FACTORY



DATA CENTER

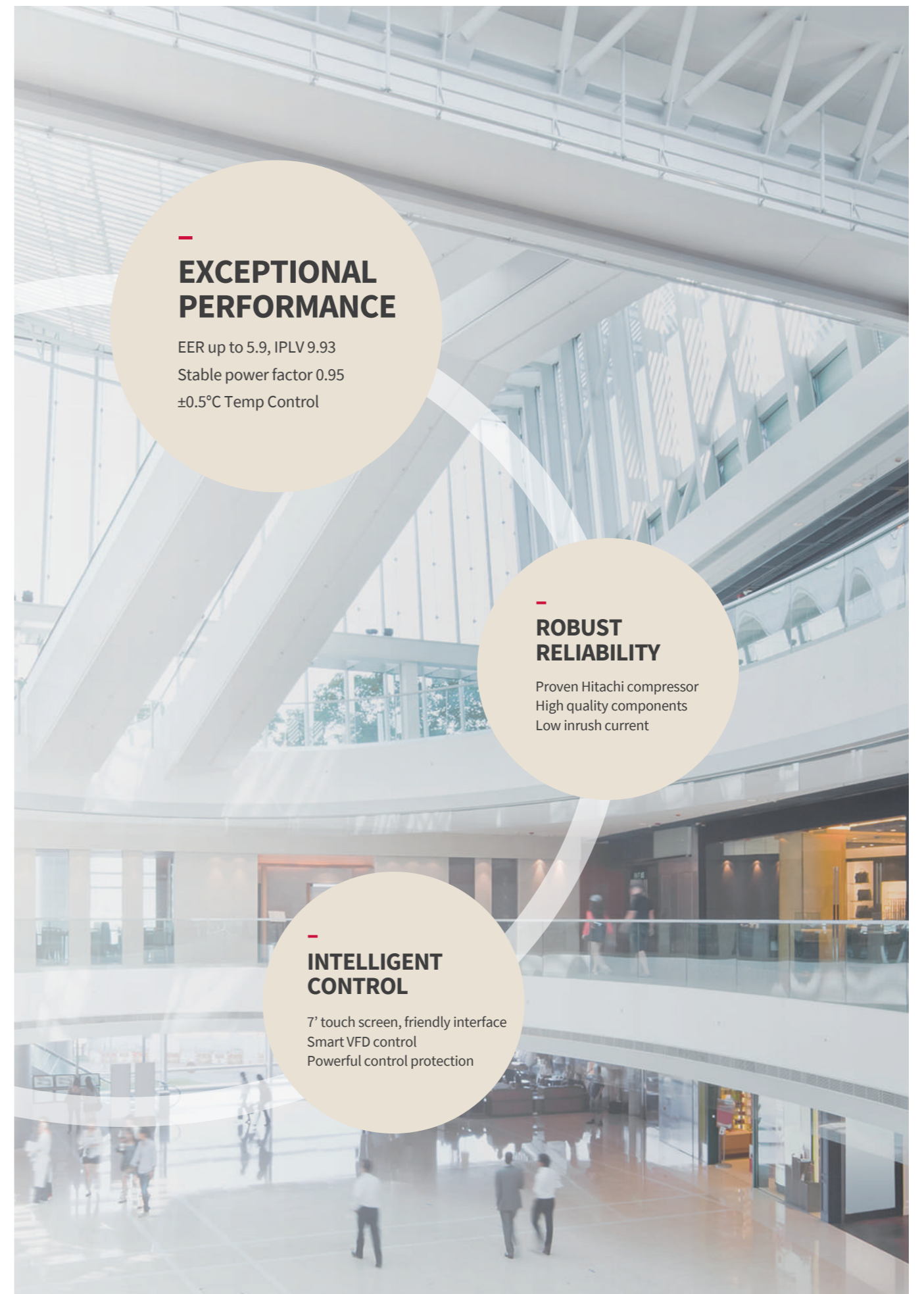

### EXCEPTIONAL PERFORMANCE

EER up to 5.9, IPLV 9.93  
 Stable power factor 0.95  
 ±0.5°C Temp Control

### ROBUST RELIABILITY

Proven Hitachi compressor  
 High quality components  
 Low inrush current

### INTELLIGENT CONTROL

7" touch screen, friendly interface  
 Smart VFD control  
 Powerful control protection

# PRODUCT FEATURES

The RCUF-WVY variable speed screw chiller will be factory-packaged and include the evaporator, condenser, compressor, VFD panel, touchscreen central controller and all interconnected unit piping and wiring. The chiller will be painted, pre-charged with oil and R134a refrigerant prior to shipment, and will be packaged to protect the unit during whilst in transit.

## COMPRESSOR

Hitachi introduced the world's first semi-hermetic twin screw compressor in the field of HVAC in 1979. Up to now, Hitachi has provided more than 200,000 twin screw compressors to customers. The WVY series of products adopts Hitachi's newly developed G type R134a compressor to provide a better overall level of value to customers.

- The new rotor, which was developed in-house, can minimize the internal leakage of refrigerant during compression.
- A semi-hermetic structure with a built-in motor has eliminated coupling design, which can prevent refrigerant leakage. Using refrigerant to cool the motor further reduces failure rates and extends the unit's lifetime.
- An adequate supply of oil is available to the compressor at all times through an advanced, pressure-differential driven oil system. There's no need for an oil pump design, which has significantly reduced the number of parts for more reliable operation and easy maintenance.
- The 15-100% stepless capacity control range is achieved through the use of variable speed control and a slide valve.

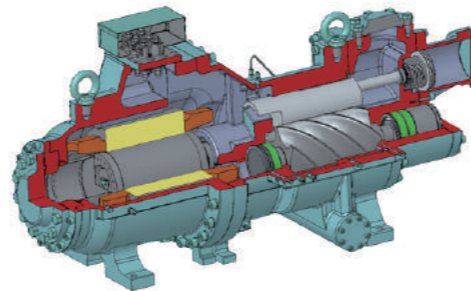

## VARIABLE SPEED DRIVE

The unit-mounted variable speed drive reduces the impact on the power grid by decreasing the inrush current at startup, and improves the part-load efficiency dramatically.

## OIL SYSTEM

The WVY series includes an external oil separator to effectively separate the oil from the refrigerant system to enhance the system efficiency. The oil system is also designed with a Venturi tube. This permits an advanced pressure-differential driven oil system, to transfer the oil in the oil sump back to the compressor, ensuring adequate oil supply at all times. An oil filter is installed in the oil pipeline to prevent any particles from entering the compressor.

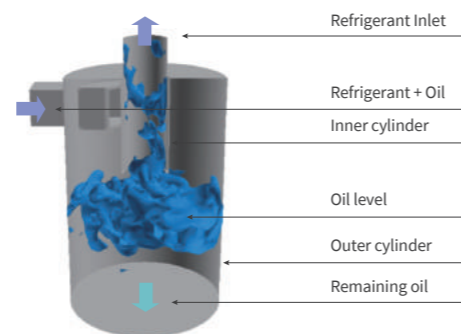

Patent centrifugal oil separation technology

## EVAPORATOR

The evaporator utilizes a flooded multi-pipe design with a new heat transfer tube for higher refrigerant turbulence that enhances system efficiency.

- The asymmetric distribution of the refrigerant inlet and outlet effectively utilizes the refrigerant properties and improves the heat transfer efficiency.
- The suction baffles design prevents liquid refrigerant carryover into the compressor.
- A sight glass on the shell side is provided for refrigerant level observation.
- Vent and drain plugs are provided on the water box as standard.
- The refrigerant side has two safety valve, one in operation and another as backup for non-stop service.
- Factory-applied thermal insulation of the flexible, closed-cell type (19mm thick), is attached with vapor-proof cement to the evaporator shell, flow chamber, evaporator tube sheets, suction connection.

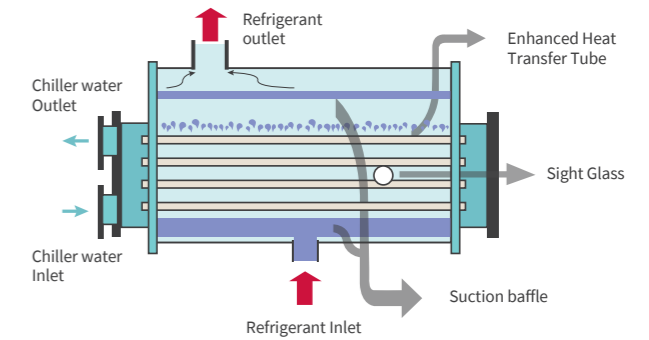

## CONDENSER

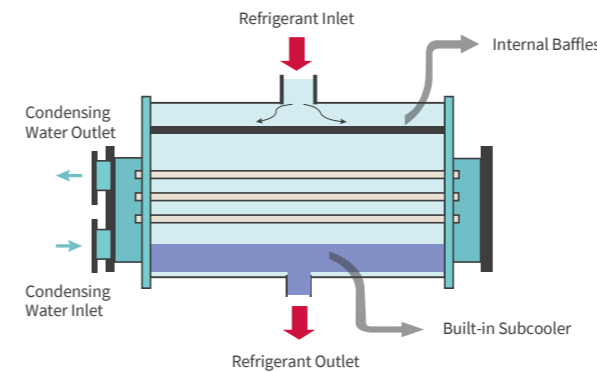

The water-cooled condenser is a cleanable shell-and-tube type heat exchanger with seamless external finned copper tubes rolled into tube plates.

- The working pressure on the water side is 1.0 MPa.
- The factory offers standard flange type water pipe connections.
- The built-in subcooler design provides the most optimized subcooling for the system.
- The refrigerant side has two safety valves, one in operation and another as backup for non-stop service.
- The vent and drain plugs are provided on the water box as standard.

## REFRIGERANT SYSTEM

- Each circuit has an orifice plate controlled to modulate refrigerant flow to the evaporator for accommodating varying head and load conditions.
- The condenser shell is capable of storing the entire system refrigerant charge during servicing. The standard check valves for the compressor and service valves are provided to facilitate removal of refrigerant charge from the system.

# ADVANCED CONTROL USER FRIENDLY INTERFACE

## ELECTRICAL CHARACTERISTICS

### Soft Start

The WVY series provides a soft start without a current shock. The start-up current will not exceed the rating current. Compared with traditional star-delta start up systems, the customer benefits from lower-cost equipment. A smaller generator also provides backup power in case of a shutdown.

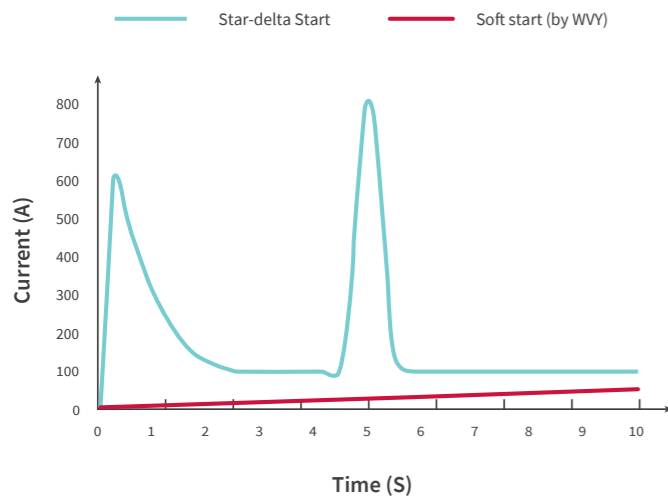

### Power Factor Correction

Thanks to a variable speed drive, the WVY series delivers a power factor as high as 0.95, and is stable in all operating conditions. Compared with a traditional variable speed drive screw chiller, the power factor will not be lost when the cooling load is raised or reduced.



## OPTIONS

### Spring Isolator

When the unit is installed on the floor, spring Isolators are recommended to replace the standard neoprene pads. The spring Isolators with non-slip mat will be delivered and can be conveniently mounted under the leg of tube sheet.

### Marine water box

The structure is designed to ease cleaning of evaporator and condenser. It is not necessary to remove the water pipe, with the hinge design, it is easy to open the water tank without any lifting tools to carry out the corresponding cleaning operation.

### Special water side pressure

The heat exchangers come with 1.0Mpa as standard water side pressure. For those special application, 1.6 MP and 2.0 MPa pressure can be offered as option.

### Paired flange

Can provide paired flange according to GB/T9119-2010 standard, or the flange design for specified standard.

### Water flow switch

Unit is shipped with water differential pressure switch, user can select paddle flow switch for field installation on water system.

### MODBUS-RTU Communication Module

The option provides the protocol communication module for unit integration with upper control system for real-time monitoring of unit operation.

### THD option

The options provides active filters to reduce the total harmonic distortion rate to 5%, 10%, 15% per requirement, help customer to meet IEEE-519 requirements.

The WVY series controller is a factory-mounted, state-of-the-art, microprocessor-based control system for R-134a screw chillers. It provides the user a superior experience in monitoring, data recording, chiller protection and operating ease.

- A 7-inch true color LCD touch screen, with simple and intuitive visual operation, allows a graphic display of the chiller, chiller subsystems and system parameters.
- Instead of requiring keystroke after keystroke to hunt for information on a small monochrome LCD screen, the touch screen control directs the user to a quick search for required information by a simple click on the icon of a given component.
- Operating conditions are clear at a glance. The operation display shows: the chilled water inlet /outlet temperature, compressor operating current, operating frequency, suction pressure, discharge pressure, suction temperature, discharge temperature, suction /discharge superheat, compressor cumulative running time, etc.
- The alarm display can also reflect recent failure records to administrators.



When the touch screen is powered on, the waiting screen is initialized. The screen will show the text, "System Initialization, Please Wait".

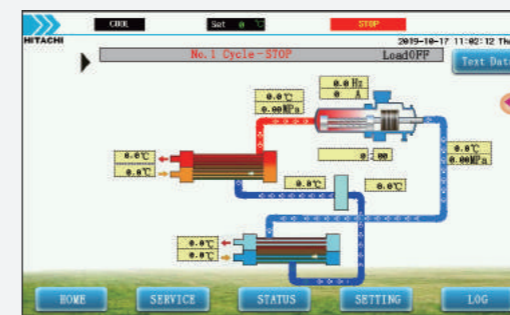

Graphic display of chiller subsystems and operation parameters



Main Menu

# ADVANCED CONTROL

## SMART CAPACITY CONTROL

### Continuous capacity control

Stepless capacity control is achieved by use of variable speed control and a slide valve in 20-50Hz frequency range to provide fully modulating control from 20% to 100% (single compressor unit) and 15% to 100% (dual compressors unit) of full-load, which allows precise capacity matching of building load and reducing unit power input, especially at part-load.

### Balancing compressor operation time

Multiple compressor units automatically balance the running time of each compressor.

### Water temperature control

Both entering and leaving water temperature control are available for different application needs. The temperature control accuracy can reach  $\pm 0.5^{\circ}\text{C}$

Temp. Control	Features	Application
Leaving Water Temp. Control	Precise leaving water temp.	Industry application (process cooling) For those require precise temp control
Entering Water Temp. Control	Higher part load efficiency	Comfortable cooling (Big building load variation) No need precise water temp those have big buffer tank design.

## SYSTEM EXTENSION

Via H-Link communication, the chiller system can support a maximum of 8 connected units.

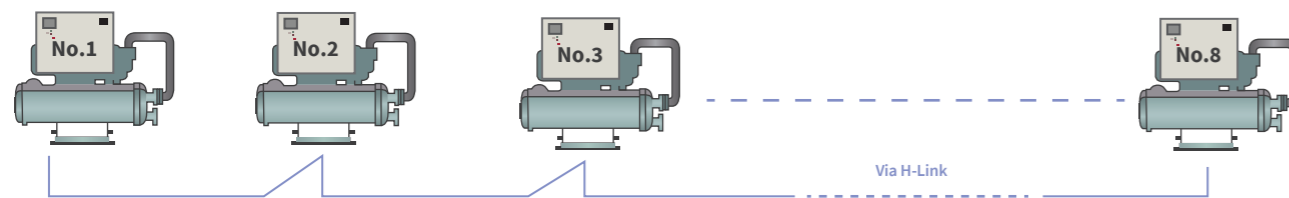

## REMOTE CONTROL / COMMUNICATION

- Stand-alone controls: the unit control system is equipped with remote start and stop contacts, and users can apply remote switch control according to their needs.
- Building automation system (BAS) controls: when the BAS communication module option is selected, users have easy access for remote monitoring and unit operation.

## COMPLETE PROTECTION

### Safety Valve

When the condenser pressure is too high and all other protective devices fail, the safety valve is opened to prevent damage to the unit.

### Three-phase Overcurrent Protection

When the current through the compressor is higher than its set value, the over-current relay will automatically disconnect the circuit and the compressor will stop running.

### High Discharge Temperature Protection

When the exhaust reaches too high a temperature, the liquid bypasses the cryogenic refrigerant cooling motor to protect the compressor.

### Water Pressure Differential Switch Protection

When the frozen water flow is too low or cut off, the water pressure differential switch operates and the unit shuts down, effectively preventing the evaporator from freezing.

### Compressor Motor Temperature Controller Protection

The thermostat is placed in the motor winding of the compressor. When the temperature of the motor is higher than the normal value, the compressor stops operating and protects the compressor.

### Oil Heater

The oil heater ensures good lubrication characteristics and prevents foaming of lubricating oil during start-up.

### Compressor Cycling Protection

By delaying the restart time of the compressor, the timer prevents the compressor from starting continuously and frequently in a short time to protect the compressor.

### High Voltage Protection and Low Voltage Protection

When the discharge pressure is higher than the set value or the suction pressure is lower than the set value, the protective device operates to stop the compressor.

### Anti-freeze Protection

When the temperature of the evaporator is lower than the set value, the element operates to shut down to prevent the evaporator from freezing.

### Inverse Phase Protection

This device prevents the compressor from running backward in of problems with the phase order of the power supply.

### Photoelectric Oil Level Switch Protection

When the compressor has been running for more than 1 minute under the condition of oil shortage, it will stop immediately and set off an alarm. This eliminates the risk of oil shortage during operation.

# SPECIFICATIONS

Type		RCUF155WVY	RCUF210WVY	RCUF260WVY	RCUF310WVY	
Capacity	kW	542	723	904	1,084	
	USRT	154.2	205.6	257.1	308.3	
Power Input	kW	92.2	123.4	155.1	183.7	
Full load COP		5.88	5.86	5.83	5.90	
IPLV (AHRI condition)		9.89	9.86	9.84	9.93	
Capacity Control Range	%	20~100%	20~100%	20~100%	15~100%	
Refrigerant	Type	R134a				
Compressor	Type	Inverter driven screw type				
	Quantity	set	1	1	1	2
	Model	HP	150HP	200HP	250HP	150HP×2
Evaporator	Type	Shell-and-Tube Type, Flooded Type				
	Water Flow Rate	m <sup>3</sup> /h	84.7	113.0	141.3	169.5
	Pressure drop	kPa	24	26	28	54
	Water Connection	Type	Flange			
		DN	DN150	DN150	DN150	DN200
Max. water-side operating pressure	Mpa	1.0	1.0	1.0	1.0	
Condenser	Type	Shell-and-Tube Type				
	Water Flow Rate	m <sup>3</sup> /h	104.9	140.0	175.1	209.6
	Pressure drop	kPa	36	38	40	60
	Water Connection	Type	Flange			
		DN	DN150	DN150	DN150	DN200
Max. water-side operating pressure	Mpa	1.0	1.0	1.0	1.0	
Flow Control		Orifice Plate				
Electrical Data	Nominal power supply	(AC3Φ) 415V/380V, 50Hz				
	Start-up method	VFD start				
	Control power supply	(AC1Φ) 240V/220V, 50Hz				
	Nominal unit current draw	A	165	221	277	328
	Maximum unit current draw	A	247	331	416	492
Dimension	Length	mm	3,275	3,275	3,275	4,687
	Width	mm	1,780	1,780	1,780	1,823
	Height	mm	2,258	2,258	2,258	2,318
Shipping Weight	kg	3,984	4,390	4,550	6,880	

Notes:  
 Performance data are rated in accordance with AHRI Standard 550/590  
 - Evaporator Water inlet/outlet temperature: 12.2°C/6.7°C  
 - Condenser Water inlet/outlet temperature: 29.4°C/34.6°C  
 - The fouling factor of evaporator is 0.018m<sup>2</sup>·°C/kW, the fouling factor of condenser is 0.044m<sup>2</sup>·°C/kW

Type		RCUF365WVY	RCUF420WVY	RCUF470WVY	RCUF520WVY	
Capacity	kW	1,265	1,446	1,627	1,808	
	USRT	359.8	411.3	462.7	514.2	
Power Input	kW	215.1	247.2	278.6	310.1	
Full load COP		5.88	5.85	5.84	5.83	
IPLV (AHRI condition)		9.90	9.87	9.85	9.82	
Capacity Control Range	%	15~100%	15~100%	15~100%	15~100%	
Refrigerant	Type	R134a				
Compressor	Type	Inverter driven screw type				
	Quantity	set	2	2	2	2
	Model	HP	200HP+150HP	200HP×2	250HP+200HP	250HP×2
Evaporator	Type	Shell-and-Tube Type, Flooded Type				
	Water Flow Rate	m <sup>3</sup> /h	197.8	226.1	254.4	282.7
	Pressure drop	kPa	56	58	60	62
	Water Connection	Type	Flange			
		DN	DN200	DN200	DN200	DN200
Max. water-side operating pressure	Mpa	1.0	1.0	1.0	1.0	
Condenser	Type	Shell-and-Tube Type				
	Water Flow Rate	m <sup>3</sup> /h	244.7	280.0	315.1	350.2
	Pressure drop	kPa	62	64	66	68
	Water Connection	Type	Flange			
		DN	DN200	DN200	DN200	DN200
Max. water-side operating pressure	Mpa	1.0	1.0	1.0	1.0	
Flow Control		Orifice Plate				
Electrical Data	Nominal power supply	(AC3Φ) 415V/380V, 50Hz				
	Start-up method	VFD start				
	Control power supply	(AC1Φ) 240V/220V, 50Hz				
	Nominal unit current draw	A	385	442	498	554
	Maximum unit current draw	A	577	662	747	831
Dimension	Length	mm	4,687	4,687	4,687	4,687
	Width	mm	1,823	1,823	1,823	1,823
	Height	mm	2,318	2,318	2,318	2,318
Shipping Weight	kg	7,195	7,510	7,775	8,040	

Notes:  
 Performance data are rated in accordance with AHRI Standard 550/590  
 - Evaporator Water inlet/outlet temperature: 12.2°C/6.7°C  
 - Condenser Water inlet/outlet temperature: 29.4°C/34.6°C  
 - The fouling factor of evaporator is 0.018m<sup>2</sup>·°C/kW, the fouling factor of condenser is 0.044m<sup>2</sup>·°C/kW

# DIMENSIONS

## OPERATION RANGE

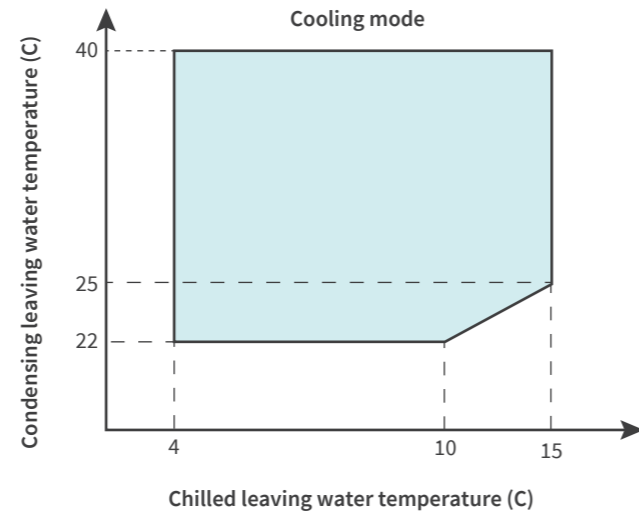

## RCUF155/210/260WVY

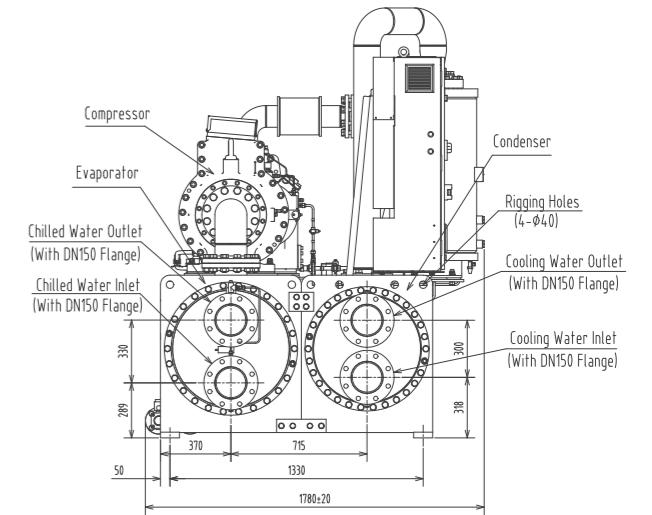
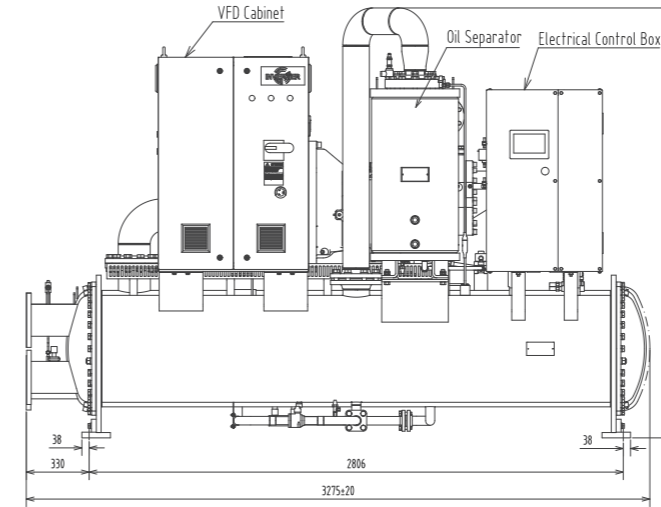

## WATER PRESSURE DROP

### Evaporator

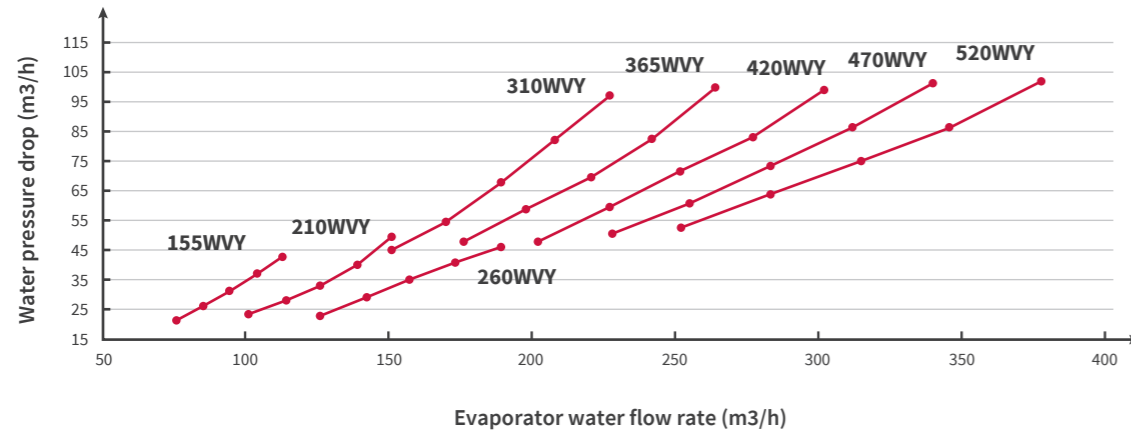

### Condenser

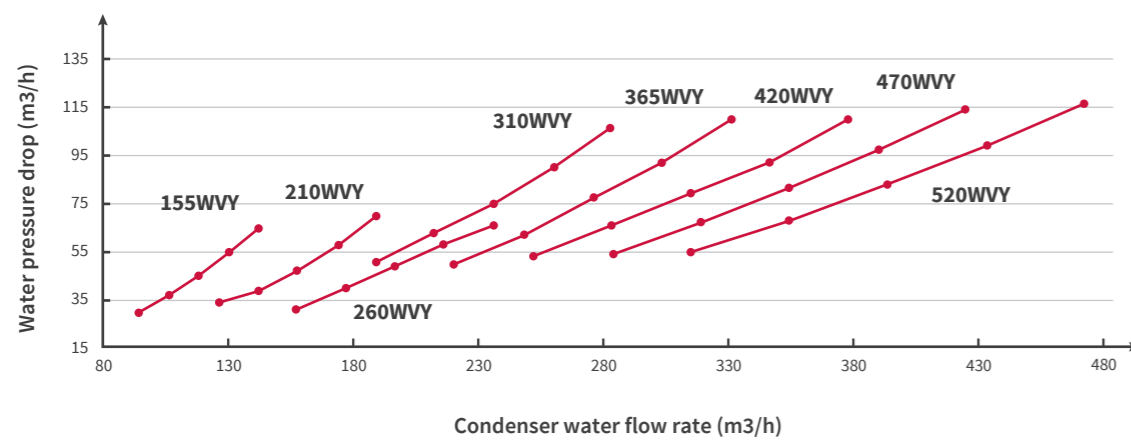

## RCUF310/365/420/470/520WVY

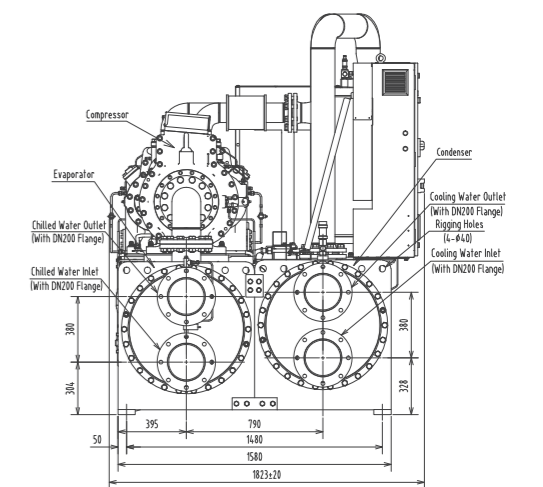
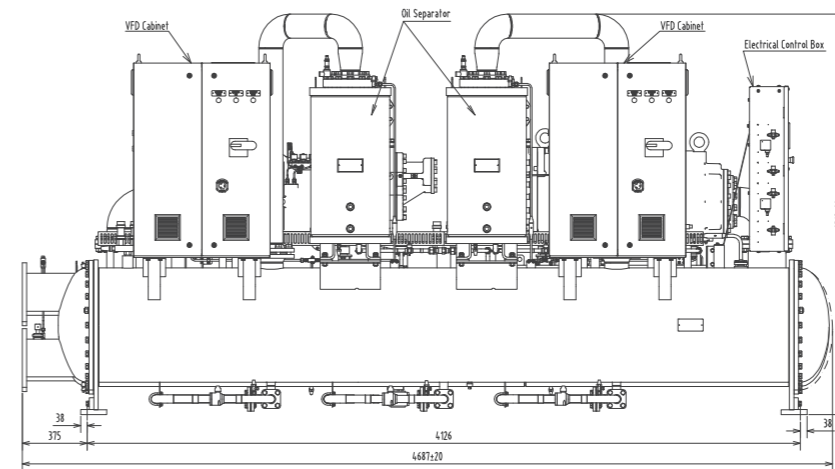

# FOUNDATION

## RCUF155/210/260WVY

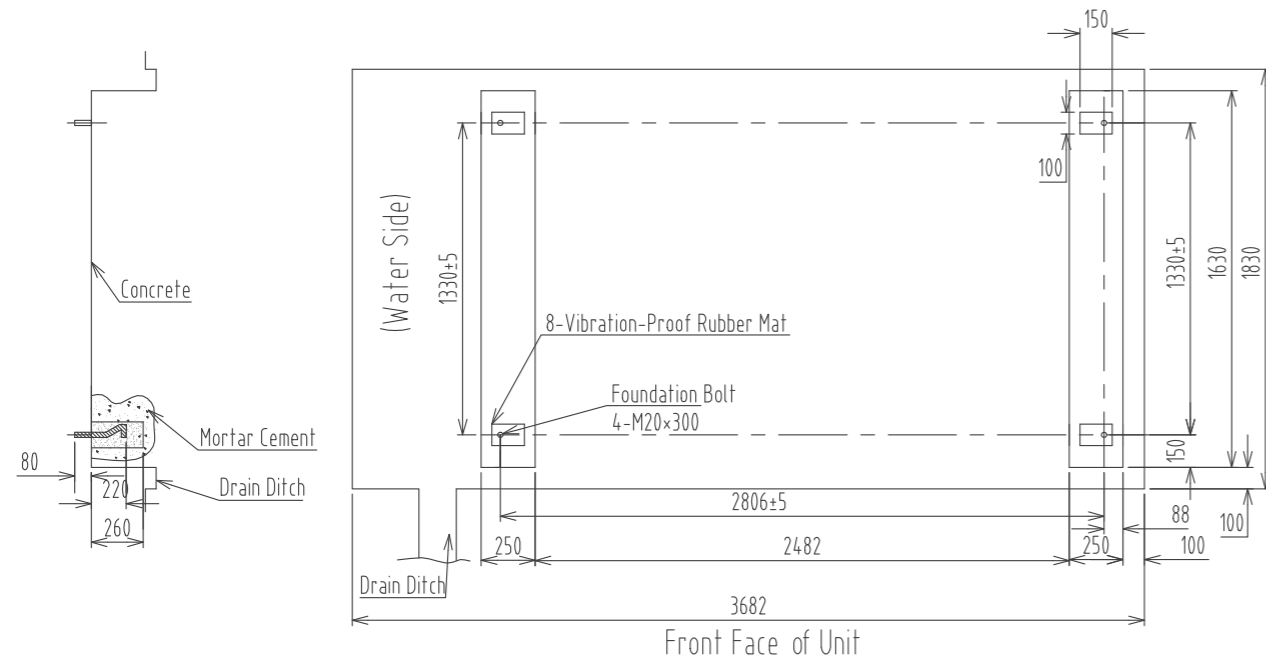

## RCUF310/365/420/470/520WVY

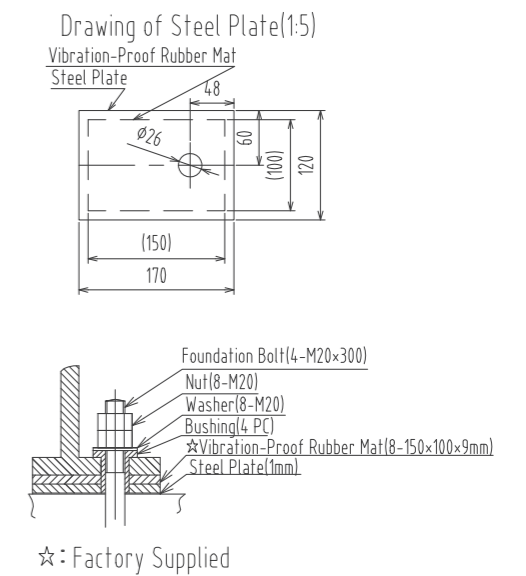
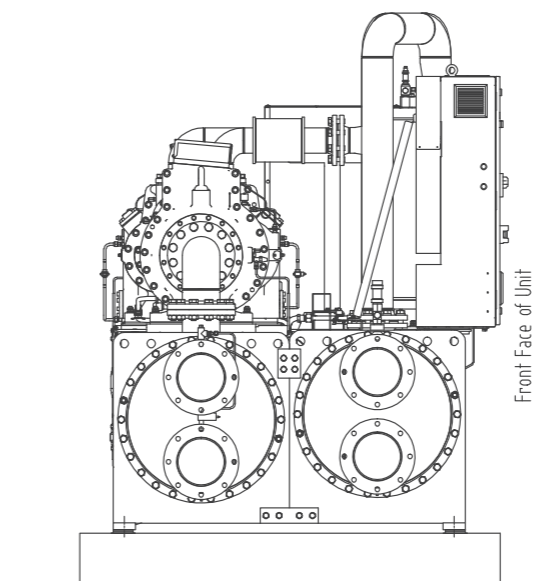
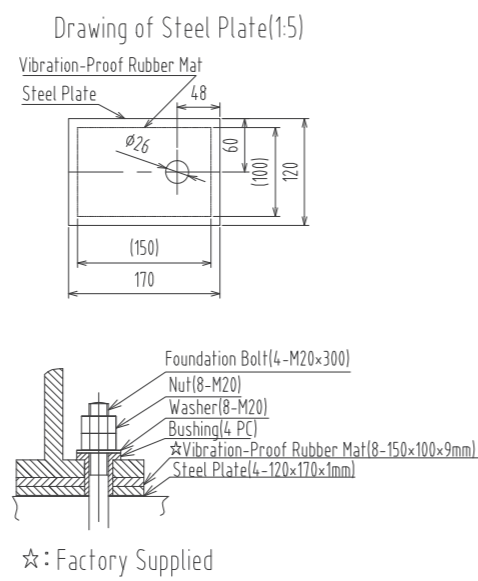
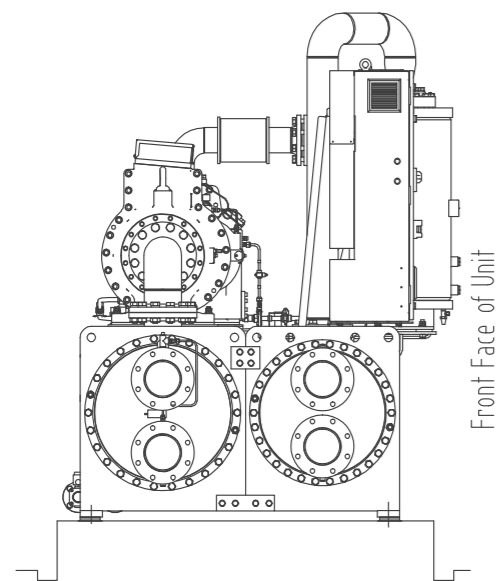
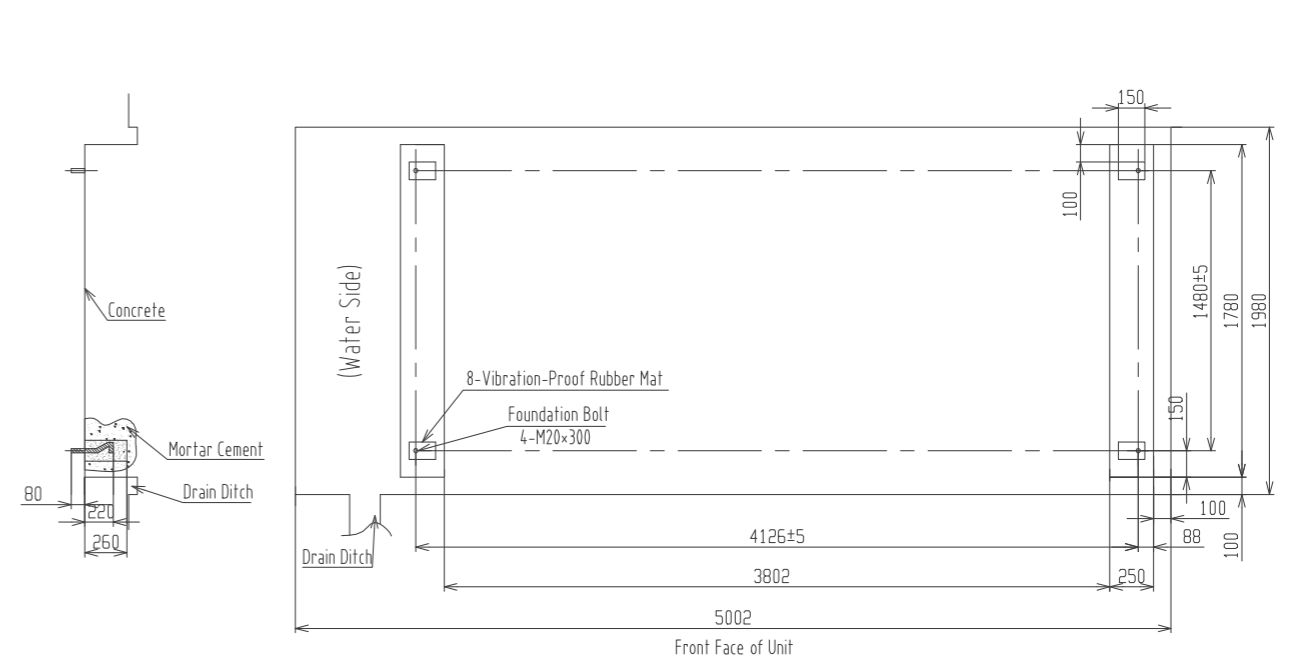

### Notes:

1. The steel plate, foundation bolt, nut, bushing and washer required for foundation installation should be prepared by the customer. Please refer to the specifications in the steel plate dimension drawing.
2. This Chiller has a vibration isolation pad. You may refer to the drawing to install two vibration isolation pads, one on the top of the other.
3. Please keep the foundation flat and apply proper waterproofing. Refer to the foundation drawing to design your drainage system.

### Notes:

1. The steel plate, foundation bolt, nut, bushing and washer required for foundation installation should be prepared by the customer. Please refer to the specifications in the steel plate dimension drawing.
2. This Chiller has a vibration isolation pad. You may refer to the drawing to install two vibration isolation pads, one on the top of the other.
3. Please keep the foundation flat and apply proper waterproofing. Refer to the foundation drawing to design your drainage system.

# INSTALLATION

## INSTALLATION SPACE

Direction	Recommended operating space	
A	≥1,200	Unit front
B	≥600	Unit front
C	≥600	Unit end (either one)
D	≥600	Unit end (either one)

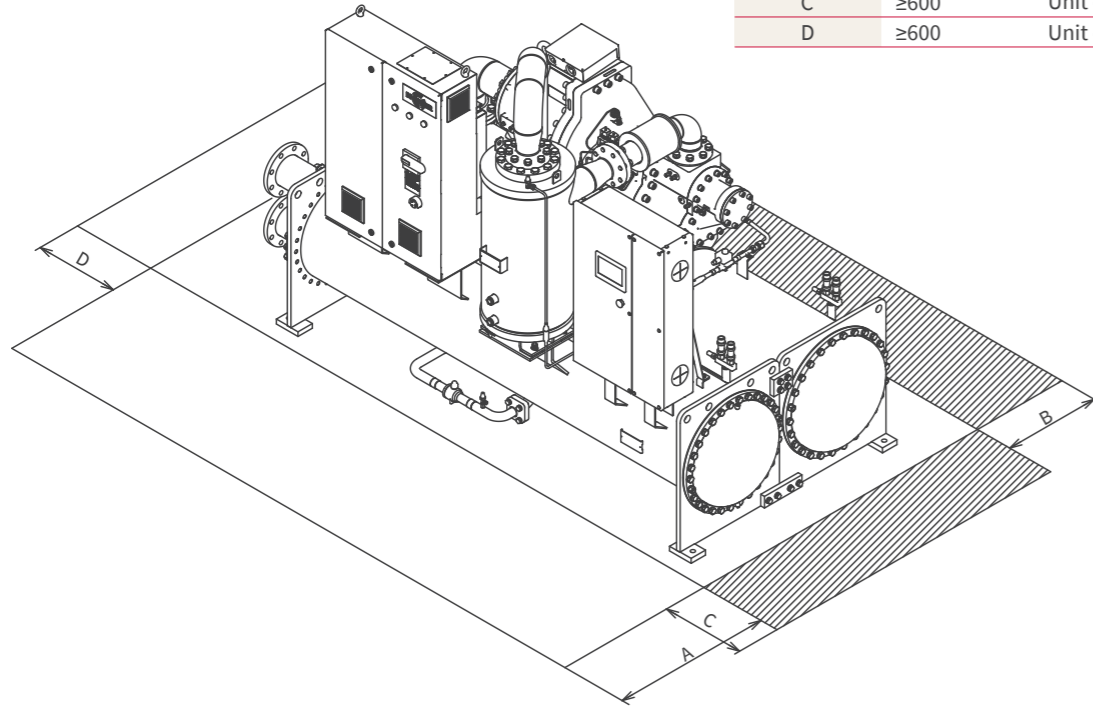

### Notes:

1. Refer to table for recommended clearance for inspection, commissioning and maintenance on jobsite.
2. The front side of the unit refers to the display side of the control box.
3. For special design units, please contact your local sales team for further information.

## INSTALLATION CAUTION

- Check whether the lifting hook is fastened tightly to the unit. The lifting angle should be greater than 60 degrees.
- When lifting, do not stand under the unit.
- Add material between rope and unit to prevent damage.
- When transporting, the inclination of the unit should not be greater than 15 degrees, otherwise the unit may tip over.

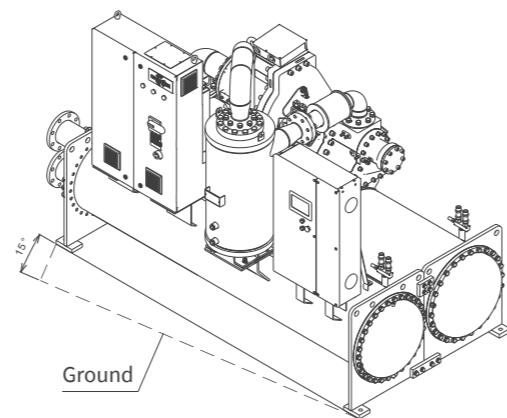

## Hitachi: Your Best Ally for Chiller Technology

Since the launch of the first screw chiller in 1980, we have never stopped innovating and investing in the air conditioning industry.



With the success of hundreds of different series and thousands of units, our footsteps can be seen around the world, from Asia to Europe to North America.

By devoting ourselves to bringing you a reliable, high-efficiency experience, we at Hitachi have created a family of chiller products that can truly meet your demands head-on.

