

air

Johnson Controls - Hitachi Air Conditioning

ADDRESS

New Pier Takeshiba South Tower
1-16-1, Kaigan Minato-ku, Tokyo 105-0022, JAPAN
Tel: +81-3-6721-5567
www.jci-hitachi.com

HITACHI. CERTIFIED QUALITY

The specifications of this catalog may change without prior notice to allow Hitachi Cooling & Heating to incorporate the latest innovations for its customers. The information contained in this catalog is merely informative. Hitachi Cooling & Heating declines any responsibility in the broadest sense, for damage, direct or indirect, arising from the use and / or interpretation of the recommendations in this catalog.

Find the products Hitachi Cooling & Heating with the best service and conditions at your Hitachi Distributor.

TFTSN(M)A5(A)-C-2309

HITACHI

airCore 600

LARGE SINGLE SPLIT
INVERTER SERIES | COOLING ONLY



Cooling & Heating



INDEX

05 Welcome

11 Connecting With You

15 Introducing airCore 600

17 Applications

20 General Features

29 Indoor Units

37 Control Systems

41 Specification Tables

Living

harmony

Welcome



Air. It's a wonderful thing

Invisible, silent and life-giving, air makes our entire world possible. It surrounds us, continuously energizing, cooling and warming. It can be unpredictable and sometimes challenging, but when air is in harmony with us, everything seems that much easier.

This is our vision.
To create the air that makes life better.

The beauty of balance

No matter what the weather is like outside, when you're indoors, you want to have complete control over your environment. At work or play, awake or asleep, you're free to create your own atmosphere; balancing energy with calm, sound with silence and light with shade. It's the same for cooling and heating.

When the air around you is in balance, you can enjoy life indoors that much more.





Living Harmony

At Hitachi Cooling & Heating we like to think of this as creating harmony with your interior environment. When we achieve that wonderful balance, productivity, learning, happiness and health can thrive.

We call this 'Living Harmony' and it's at the center of everything we do.

We live & breathe innovation

Since 1952, Hitachi's Cooling & Heating technology has been helping make life more harmonious for people around the world. Today, our long heritage of precision Japanese engineering ensures that no detail is overlooked in our quest to create Living Harmony.



The future together

Living Harmony puts people first. By balancing the human needs of our customers with an uncompromising approach to innovation and quality, we can continue to create the technologies for a more comfortable and balanced world.

Your world. We live in it together.

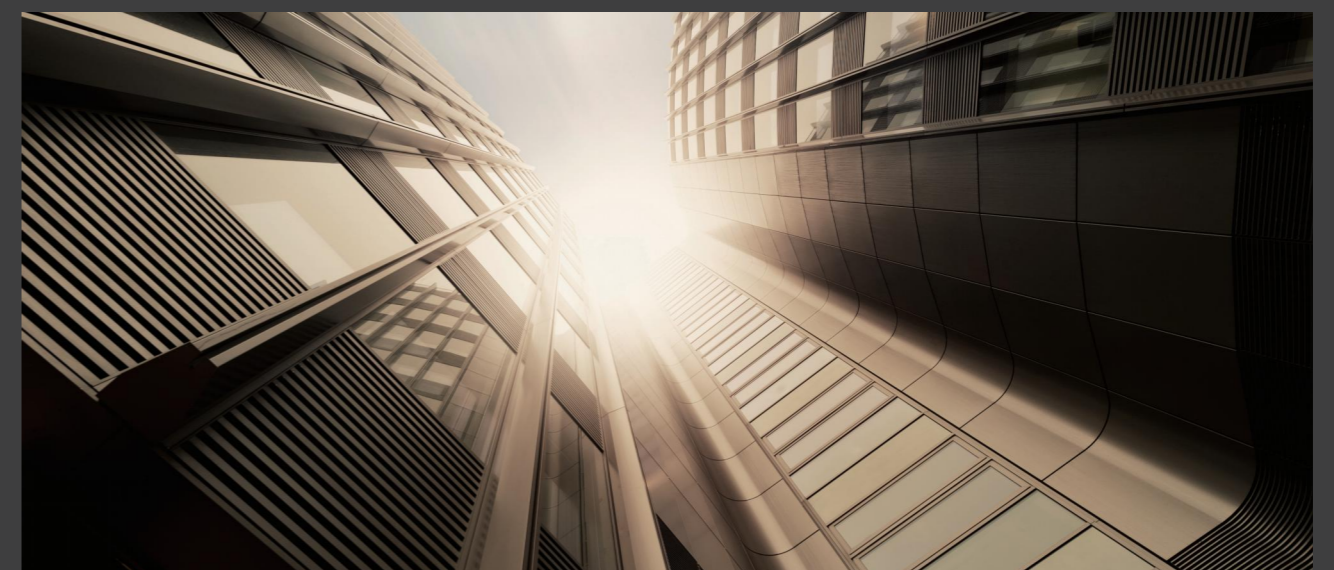

Your world

**We live in it
together**

Connecting with you

Reaching out

Finding the right appliances can be tricky. airCore 600 is an air-conditioning system that was created to become a part of your long-term surroundings.



airCore 600 units integrate smoothly into your daily life, improving the experience for everyone involved with your business. Our range is especially adapted for places such as shops, restaurants, cafés, creative studios, galleries, workshops and classrooms.



At your service

Your environment will always be filled with fresh air, at the temperature needed, with a minimum of effort or irritation.

Our aim is to bring greater comfort to your working days and to your customers' visits to your store, office or workspace.



Made for you

Each component of your new system will arrive ready for rapid installation and operation. Units not only combine advanced software and hardware design, they are assembled with care. Every unit undergoes rigorous testing before it is shipped, ensuring it will withstand any challenges the climate presents.

To accommodate your space, flexible piping and a comprehensive capacity range are available. When facing a unit malfunction, error codes will be clearly displayed to facilitate maintenance. There is always an airCore 600 solution suited to your needs.



Striving for perfection

A set of strong beliefs and practices at Hitachi have paved the way for generations of efficient products. airCore 600 represents the culmination of significant collective effort, giving the series a great advantage – and making airCore 600 the right way to go, for you, your employees and your customers.

Your loyal partner

Assisting you by improving the temperature and quality of air in your workspace is our role as a partner. You can count on us to provide systems that increase comfort and exceed expectations.



Customers from across the globe have voiced concerns to us in the past about how their systems have held up over time. In developing airCore 600, we've taken extra measures to extend unit life through the application of sensors, special coatings, and durable surface materials.



Introducing **airCore** 600

airCore 600's aims

The airCore 600 is designed to cater to the requirements of individuals residing and working in compact to medium-sized spaces, ensuring the provision of clean and comfortable air. The name 'airCore 600' symbolizes our commitment to furnishing people with healthy and comfortable living environments.

Some features may not apply to the units sold in your country.



236mm

Seamlessly compact design

Our new unites are up to 8.7% thinner than previous models, which allows the compact design to seamlessly and discreetly blend into your space.

48°C

High ambient cooling

Our systems deliver consistent cooling to customers in warm climates. airCore 600 units are designed for reliable performance during high-ambient temperatures up to 48°C.

GWP 675

Environmentally-forward refrigerant

With sustainability as a priority, the R32 refrigerant has lower rates of ozone depletion and global warming than ever before. This further protects the environment and our planet's future.

50m

Wider coverage

There is extended flexibility in our piping. During installation, piping can reach up to 50m in length and up to 30m in height, customized to your space's needs.

Reliable partners for small businesses

Every business benefits from a comfortable, quiet environment. That's why reliability, adaptability to physical settings, and precise control for users were priorities in the airCore 600 system.

Diligent manufacturing

Intensive research and development went into the airCore 600 system to ensure stable operation of key pieces of equipment, such as the compressor, in both typical and extreme temperatures. It is also reflected in product features such as auto restart after power failure and self-diagnosis of faults.

Design for different spaces

Different indoor units can be matched with individual spaces to meet customers' needs around aesthetics, comfort, maintenance, and control.

Meeting your needs is our goal

Your requirements for a harmonious living and working space are our central concern. Building on previous innovations and current research, we have developed a series that targets core needs shared by global users while enabling customizations for specific space requirements.

Your spaces & airCore 600

You, your colleagues and customers deserve to feel comfortable in every situation. This means finding and installing the ideal unit for your particular interior, a process we will be happy to help with. You can also rely on us for timely maintenance and repair when needed.



“Having a comfortable setting is essential. The air-conditioning system that is installed is a big part of this.”

Restaurant & Café

Retail Space

Small Work Space

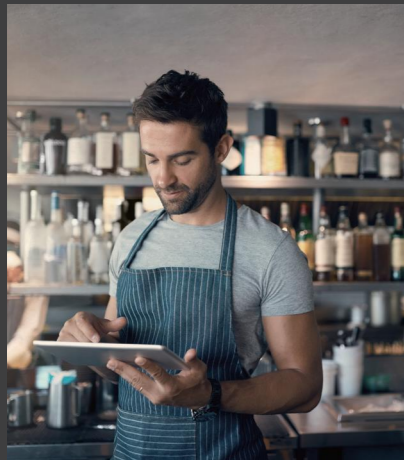

“Running a café means noise, buzz, activity and trapped heat. Having a correct and consistent A/C lets my customers relax and enjoy their drinks – and I can see the difference in their moods.”



“I work with clothes, and the fabric can heat up in summer and make things stuffy. The store is cold in winter. Without the system to regulate things all year round, the seasons would really get to me.”

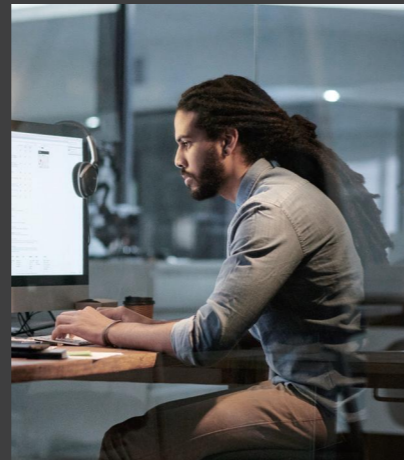

“I stay late at the office along with my colleagues if there is a big project to finish. Having a comfortable setting is essential, and the airflow system that management installed is a big part of this.”

They might not know each other, but we know them: A community of customers around the world is connected by hard work and a commitment to a harmonious environment. We at Hitachi will always strive to support them.





General Features

Features, advantages and benefits

airCore 600 fits seamlessly into any lifestyle. For a small business or other interior space, controlling ambient temperature is effortless. airCore 600 works with you to create a more balanced environment so you can focus on what matters most.

COMFORT & CONVENIENCE

Comfort and convenience are our top priority. Choose one of the two airCore models to enjoy uncommon comfort, control, and satisfaction.

INTERLOCK CONTROL INTERFACE WITH EXTERNAL DEVICES

Convenience is important especially for our busy working lives. Our expandable interface makes life a little easier that allows you to connect to smoke detectors, key slots, or other devices. The reserved port that will help connect all of these into one accessible device so you can get things done with ease.

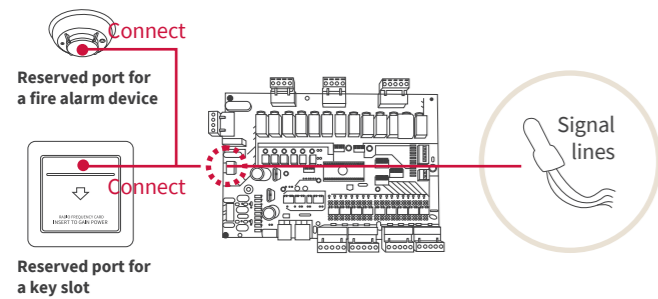

e.g., Hotel key card systems, where guests can insert their room's key card to use power.

ERROR SELF-DIAGNOSIS FUNCTION

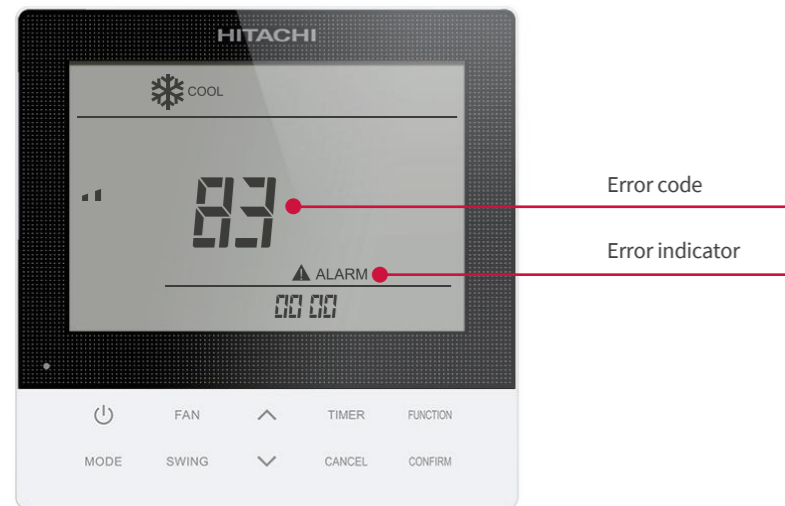

The error self-diagnosis function helps scan your system to help identify specific problems thus making repairs more effective and efficient. The error code will be displayed on Wired Remote Controller and outdoor unit control board for quick hassle-free troubleshooting.

This will help you save time and resources which would have otherwise been wasted.

ECO-FRIENDLY REFRIGERANT

With sustainability as a priority, the R32 refrigerant is rated to have Zero Depletion Potential and lower Global Warming Potential which helps protect the environment and our planet's future.

	Ozone Depletion Potential	Global Warming Potential
R32	0	675
R410A	0	2,090
R22	0.05	1,810

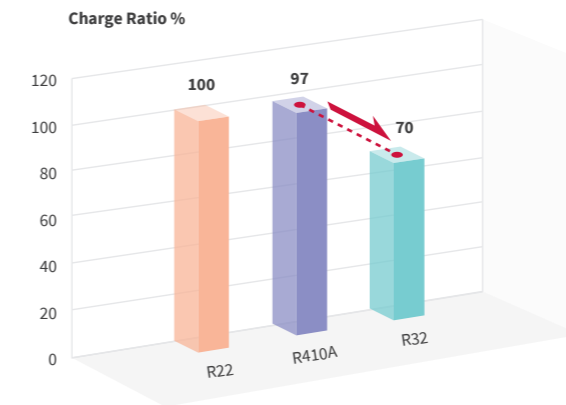

In case that all refrigerant have the performance equivalent R22

ECONOMIC OPERATION

Impressively low operating cost is a key advantage of inverter air conditioners. We've combined advanced inverter technologies with cutting-edge electronics and mechanical technologies to achieve a synergistic effect that enables improvements in heating/cooling performance efficiency. Better performance and lower energy consumption are the results.

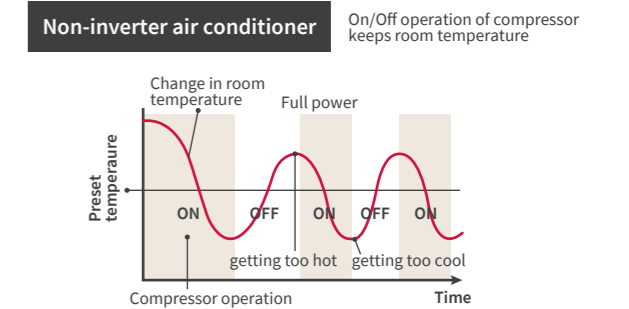

AUTO-RANDOM RESTART

Once power is restored to the units after an outage, the units will automatically restart in a few minutes with each unit restarting at a random interval. The auto-random restart feature prevents the units simultaneously overloading the circuit with power. Your units will automatically revert back to your previous custom settings for a speedy, worry-free return to comfort.

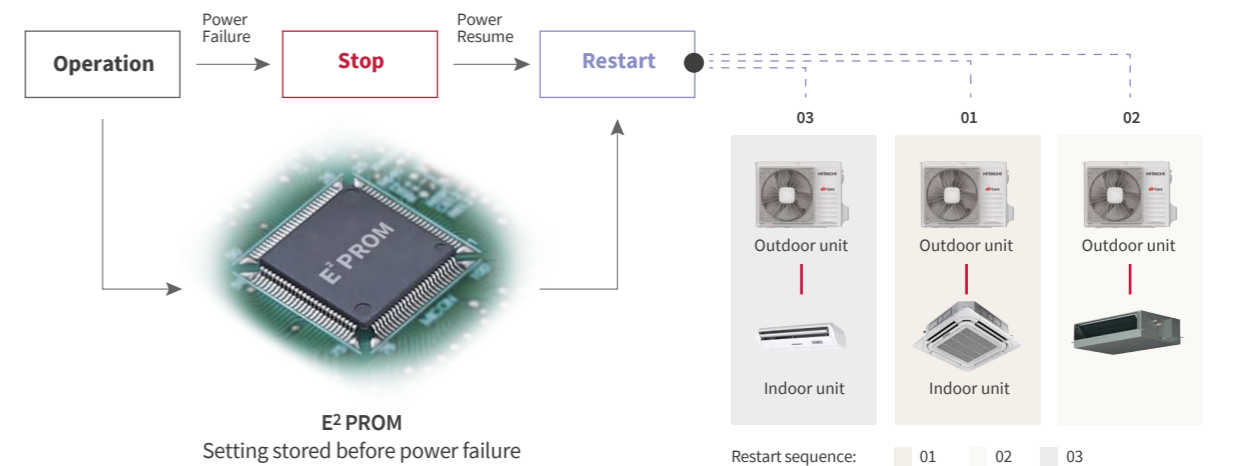

EFFICIENCY

One way to reduce operating costs is to eliminate unnecessary energy consumption, which is crucial in maximizing sustainability. To avoid wasting energy and cost when running air conditioners, in accordance with our strict quality standards, we have dedicated ourselves to make sure our air conditioners run smoothly and efficiently without interruptions.

EFFICIENCY RATIO

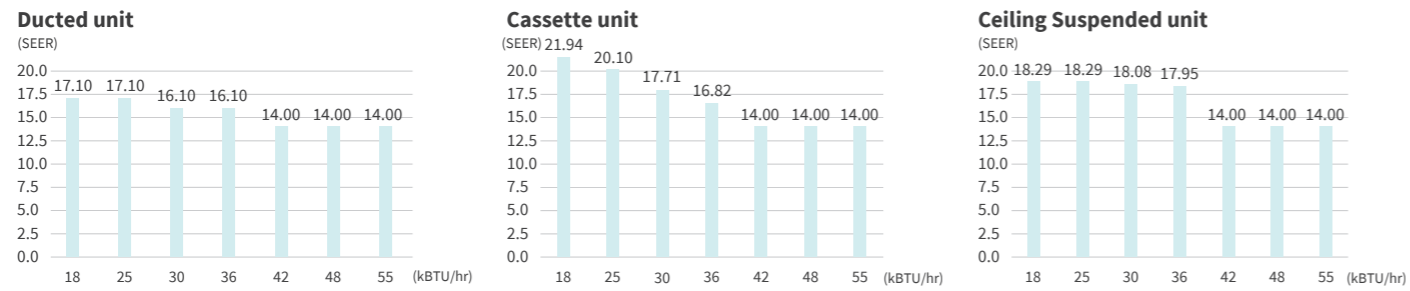

HIGH EFFICIENCY COMPRESSOR

Powerful cooling performance at standard and high ambient temperature: High efficiency attributed to high performance twin rotary compressor. Twin rotors balances out centrifugal load resulting from rotation. Reduce compressor vibration, lower noise level, and increase reliability.

WIDE AMBIENT TEMPERATURE RANGE

No matter how harsh the outdoor temperature is, airCore units are able to operate at temperatures that range all the way down from 16°C to up to 48°C. This provides high heating and cooling performance in a wide ambient temperature range.

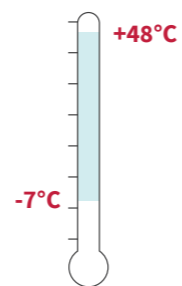

Cooling mode

HIGH EFFICIENCY FIN

The fins are an integral component of the unit that transfers and radiates heat. With our newly refined design, the fins facilitate improved heat exchange and contribute to greater efficiency, making it a energy-effective choice.



RELIABILITY

Peace of mind comes when you no longer have to think about it. Hitachi's airCore 600 units are self-diagnosing when it comes to components that could malfunction due to unforeseen circumstances.

We have installed failsafe features in key areas that help protect the unit from damage or failure. These features reduce maintenance costs, ensure consistent performance, and extend the life of your unit.

SAFETY PROTECTION

A fully enclosed metal box ensures product safety and most importantly the PC board.

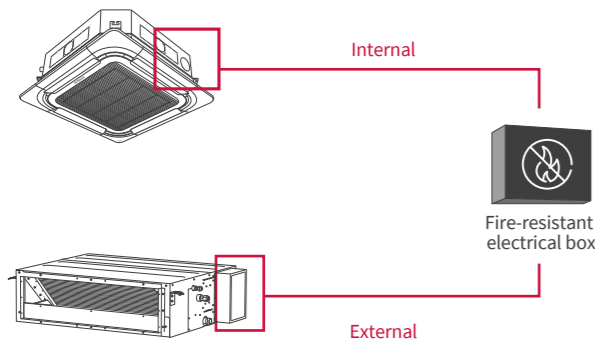

HIGH RELIABILITY OF COMPRESSOR OPERATION

Viscosity testing was taken for compressor in order to ensure the reliability of the running.

1. Compressor overheating protection:

To keep the compressor working within a safe range, the compressor includes a dual protection system, consisting of an exhaust temperature sensor and an overheat protection switch.

2. Discharge temperature sensor

Ensures the compressor will operate in the safety range and prevent damages caused by overheating from refrigerant leakage.

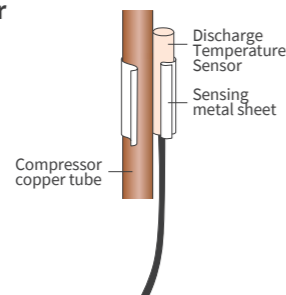

OTHER PROTECTION SYSTEM

1. Fan motor overheating protection:

Sensors safeguard the unit from overheating, which helps preserve the motor.

2. Galvanized Steel Appearance

Duct structure adopts galvanized steel design for durable strength, and anti-corrosion protection.

CORROSION-RESISTANT (OPTIONAL)

A hydrophilic aluminum fin enhances heat-exchanging performance by increasing water movement on fin surface and preventing blockages between fins. Any condensation or moisture build-up leads to more accumulated dust and bacterial growth. A special, anti-corrosion blue coating enhances protection from environmental and microbiological factors, increasing reliability and ensuring uniform performance.

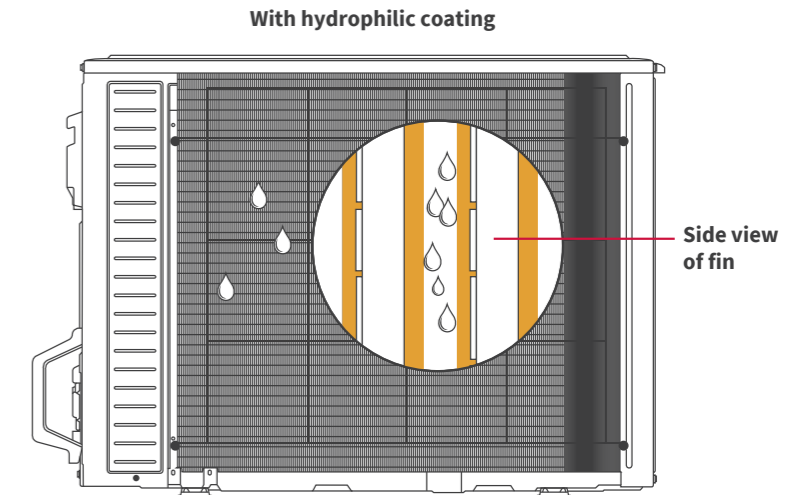

The coating prevents water droplets collecting on the fins and causing dirt.

REFRIGERANT LEAKAGE DETECTION

When the sensors detect a refrigerant leakage, the indoor unit will automatically shut down, protecting the compressor from damage caused by high temperatures. It will also display an error code, which will identify the refrigerant leakage and help with diagnosing the appropriate solution. This increases the heat transfer efficiency and unit safety.

REFRIGERANT LEAKAGE ALARM

The indoor unit automatically stops when it detects refrigerant leakage and show the error code, providing extra protection.

DURABLE PROTECTION DRAINAGE SYSTEM

The specially designed drain pan makes condensate water flow smoothly without leaking, preventing rust.

When there is a problem with the water pump and the water level rises to a certain level, the float switch will trigger the unit to turn-off, indicating the need for maintenance.

PEST-RESISTANT ELECTRICAL BOX

A protective casing keeps the PC board safe from potential damage by unwanted pests, such as insects and rodents.



The circuit board is encased in a protective 0.5mm-thick coating to keep out dust and pests.

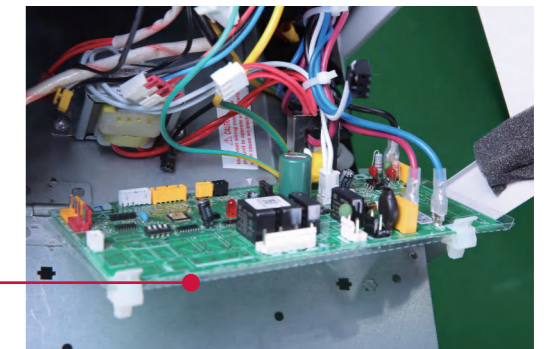

HIGH TEMPERATURE RESISTANCE PCB

The PCB board in the inverter air conditioner can still run. Normally under the high temperature of 85°C. No fear of high temperature operation.

DESIGN FLEXIBILITY

EASIER HANDLING OUTDOOR UNITS

Moving large objects is no easy feat. Flexibility is built into the airCore 600 system with multiple outdoor unit options available. Each is modular and easy to install in a variety of settings.

COMBINATION OF MODULES

Your space is very valuable, we offer four different options for various dimensions and power to better suit your needs.

RAS-B18TFTSNA5
RAS-B18TFTSNA4

Dimension (W×H×D)
810×580×280mm

Model
18K

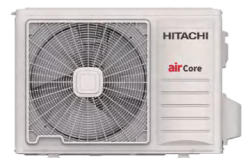

RAS-B25TFTSNA5 RAS-B30TFTSNA5
RAS-B25TFTSNA4 RAS-B30TFTSNA4

Dimension (W×H×D)
860×670×310mm

Model
25K, 30K



RAS-B36TFTSNA5
RAS-B36TFTSNA4

Dimension (W×H×D)
900×750×340mm

Model
36K

Dimension (W×H×D)
950×840×340mm

Model
36K



RAS-B42TFTSNA4

Dimension (W×H×D)
950×1,050×340mm

Model
42K



RAS-B42TFTSMA5
RAS-B48TFTSMA5
RAS-B55TFTSMA5

Dimension (W×H×D)
900×1,170×320mm

Model
42K, 48K, 55K

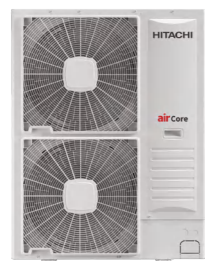

RAS-B48TFTSMA4
RAS-B55TFTSMA4

Dimension (W×H×D)
950×1,386×340mm

Model
48K, 55K



CONVENIENT INSTALLATION

Free of unnecessary or weighty components, each unit can be carefully slid into place by the installation team.

Four access can be selected for pipe connecting

Available for models:

- RAS-B42TFTSMA5
- RAS-B48TFTSMA5
- RAS-B55TFTSMA5

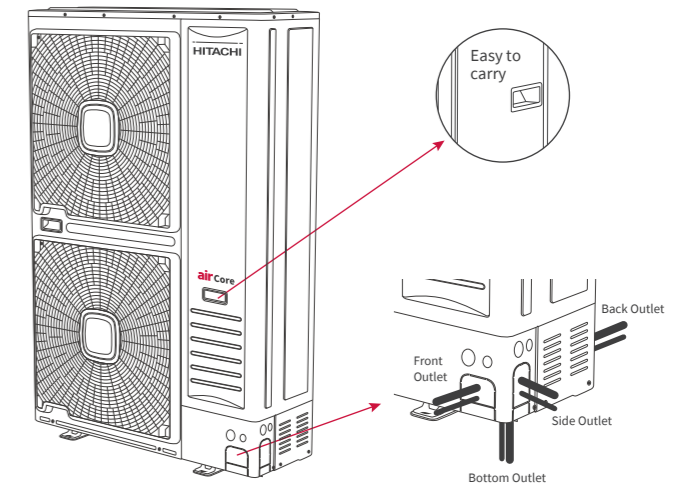

MORE FLEXIBLE PIPING

Specific applications may require short or long piping to obtain proper placement of indoor units for optimal air distribution. Hitachi airCore 600 systems can accommodate both.

Long piping and large height difference

Accommodating up to 50m of piping run and 30m in height, this offers a great deal of flexibility in terms of installation.

Piping	Model	18K	25K	30K	36K	42K	48K	55K
Diameter (Liquid)	Inch	1/4	3/8	3/8	3/8	3/8	3/8	3/8
Diameter (Gas)	Inch	1/2	5/8	5/8	3/4	3/4	3/4	3/4
Max Length	m	30	50	50	50	50	50	50
Max Height	m	15	30	30	30	30	30	30

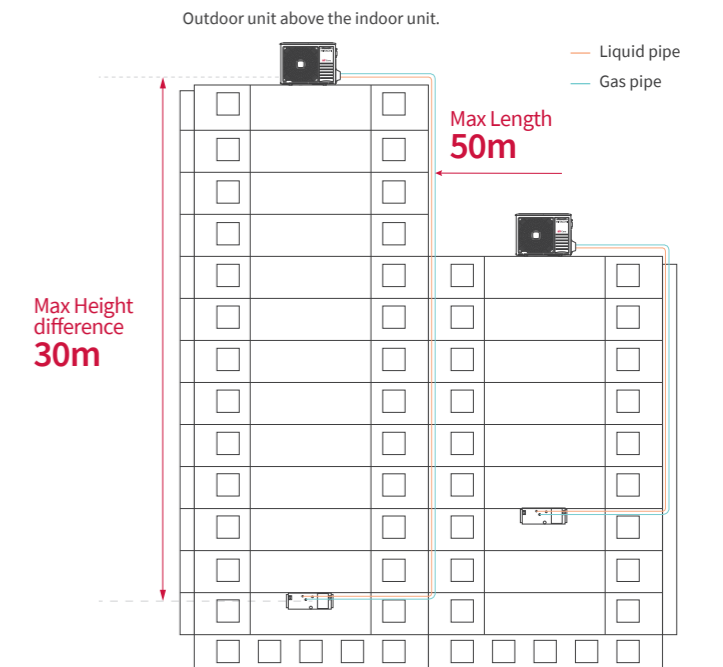







Note: only available to model 25K-55K

Hitachi airCore 600 indoor units contribute to a sense of well-being by making indoor life more comfortable. Units are unobtrusive, reliable, and ultra-efficient, creating a comfortable environment that enables you to stay on track and get things done.

LINE-UP OVERVIEW

Indoor Unit Category

Model	18K	25K	30K	36K	42K	48K	55K
Ducted unit		•	•				
				•	•		
						•	•
Cassette unit		•	•	•			
					•	•	•
Ceiling Suspended unit		•	•				
				•			
					•	•	•

FREEDOM OF CHOICE

Which unit or units should you choose?

In our airCore 600 series, there are two main units:

Ducted and Cassette.

See which options are best suited for your application.

Fresh Air Inlet

The optional fresh air function brings outside air in, keeping rooms well-ventilated and indoor environments fresh.



Cassette

Cassettes have the advantage of providing more consistent temperatures when used in larger, more open space such as offices or commercial spaces. This is because they provide greater coverage while improving airflow.



HCRB31NEWH
(Standard)



HCWA21NEHH
(Optional)

Incorporating cassettes into a standard ceiling grid will allow you to easily place light panels and other overhead lighting fixtures in narrow ceiling cavities or high ceilings. The cassette unit remains unobtrusive and out of the way.

FEATURES & BENEFITS

COMFORT

Maximum Airflow

Louvers are adjustable for 360-degrees of all-around airflow. Smooth airflow can be directed towards every corner of the room—or even a particular area for precise comfort.

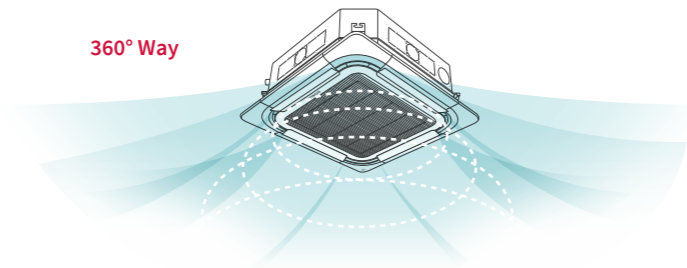

Larger Louvers and Wider Openings

With our larger automatic swing-louvers, you get better control of the room's airflow. For cooling and dehumidification, the fan louvers have adjustable openings between 35-60 degrees.

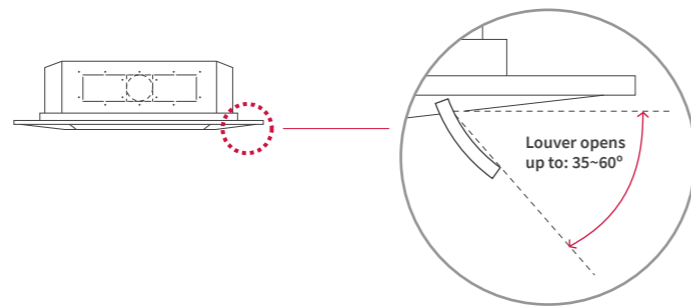

Power Centrifugal Fan

Made of anti-shock ABS and a resilient glass-fiber composite, the centrifugal fan's blades are designed for an optimized and stronger air flow.

Reduce motor power consumption by 22%

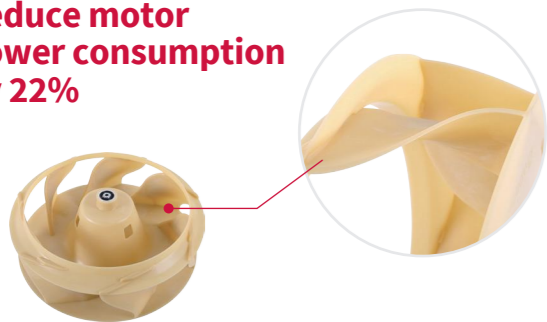

Application in High Ceiling Installation

Unit installation at different ceiling heights is possible by adjusting field setting for airflow compensation.

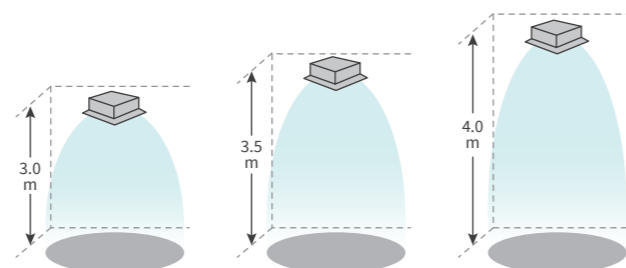

Notes:
Field setting need to be done via WRC. If ceiling height is higher than 4m, the function may become limited.

Efficient Evaporator Coil

Compared to the cassette unit, this advanced evaporator coil has 6% greater efficiency, absorbing heat faster and ensuring optimal performance.

Increase:
6% ↑



Fresh Air Intake

Bring fresh, healthy outdoor air into rooms with the fresh air inlet.

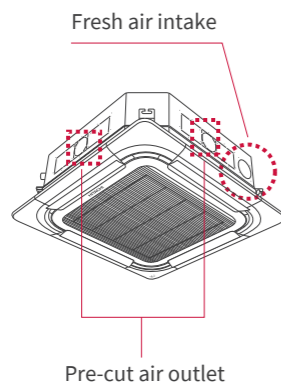

Pre-cut air outlet reserved for round or rectangle branch duct connection

Possible to supply air through a pre-cut internal air duct port, enhancing air circulation.

CONVENIENCE

Seamless Integration

Our units integrate smoothly into your daily life with designs that adapt to a wide range of spaces, such as shops, restaurants, cafés, classrooms, workspaces, hotels, and even your home.

And with the new sleek LED display, status updates are now even more subtle, so you can focus on what matters most.

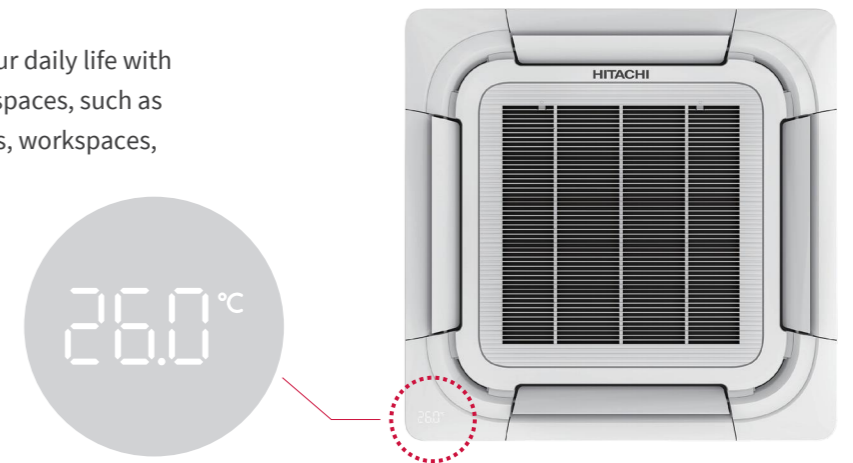

Compact and Light

The compact design makes the unit particularly discreet, allowing it to be placed in confined spaces.

	Series	25K	48K
Thickness (mm)	R-410A	248	298
	R-32	236	272

Reduction of thickness:
4.8% – 8.7%

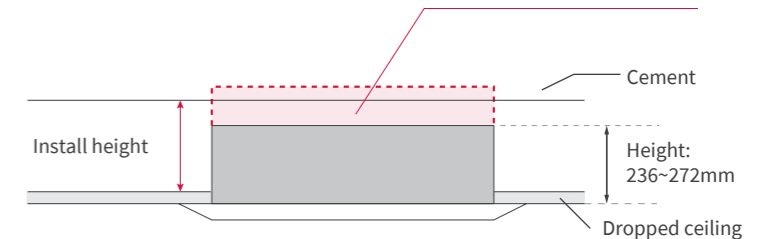

Reusable Filter

The filter is easily washed and cleaned, allowing it to be reused again and again, saving monetary and environmental costs.

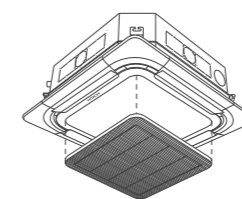

Antimicrobial module (optional)

With the antimicrobial module affixed to the drain pan, it prevents the growth of bacteria and reduces the emission of odors.

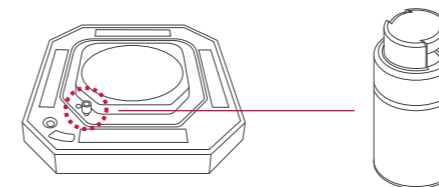

Reliable Condensate Pump

The versatile design allows the condensate pump to be customized to your space.

With the ability to pump water up to 1200mm and an automatic safety switch to prevent condensation overflow, you can depend on high performance and efficiency.

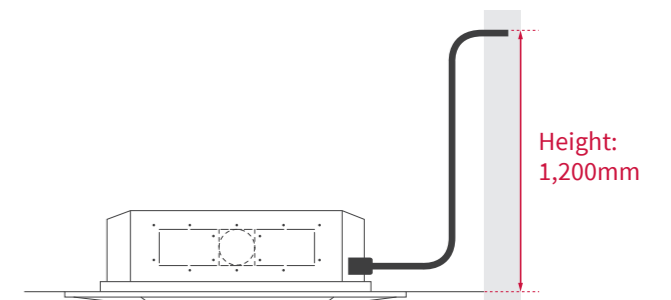

Ducted

Quiet, long-lasting ducted systems provide uniform heating and cooling throughout your indoor space, significantly reducing energy consumption. They also provide superior air circulation which is especially beneficial for anyone with allergies or asthma.



HCWA21NEHH (Standard)



HCRB31NEWH (Optional)

The compact design makes the ducted unit particularly discreet, allowing it to be placed in confined spaces.

FEATURES & BENEFITS

COMFORT

Durable Protection Drainage System

This specially designed drain pan prevents leaks while effectively allowing condensate water to drain better, preventing rust for longer unit life. When the drainpipe is clogged and the water rises to a certain level, the float switch will send a signal to turn off the unit.

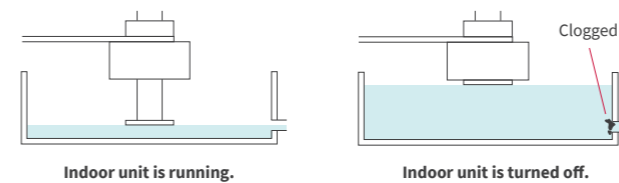

Built-in drain pan

Compared with an external drain pan design, the new built-in drain pan can reduce dust adhesion and avoid water leakage. With a larger surface area and an absorbent foam layer, water is directed to flow more smoothly. Made with galvanized steel for durability, strength, insulation, and anti-corrosive properties.

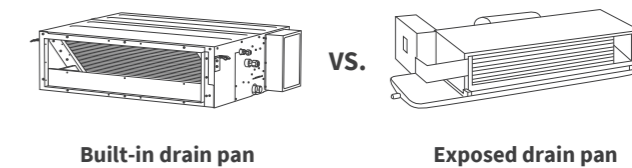

DESIGN FLEXIBILITY

Wide ESP range up to 150Pa*

A wide ESP range means airCore 600 is suitable for spaces with many discrete areas, including corners and recesses. Multiple outlets can be connected to the ducted unit to ensure uniform air delivery even around tight spaces. This system is easy to assemble quickly and accurately.

For example:

50Pa:

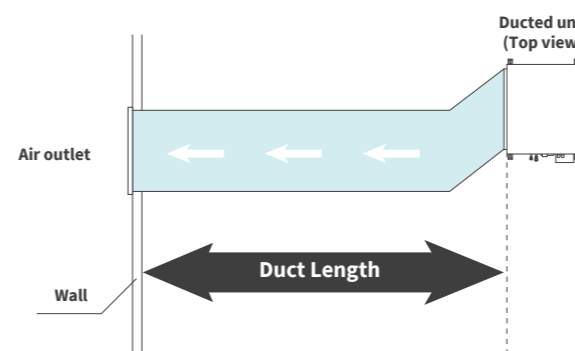

*except 18K-36K

1 Pa incremental ESP Setting

It is possible to adjust the ESP setting via wired controller. And the precision of 1 Pa can give the most accurate ESP setting in class.

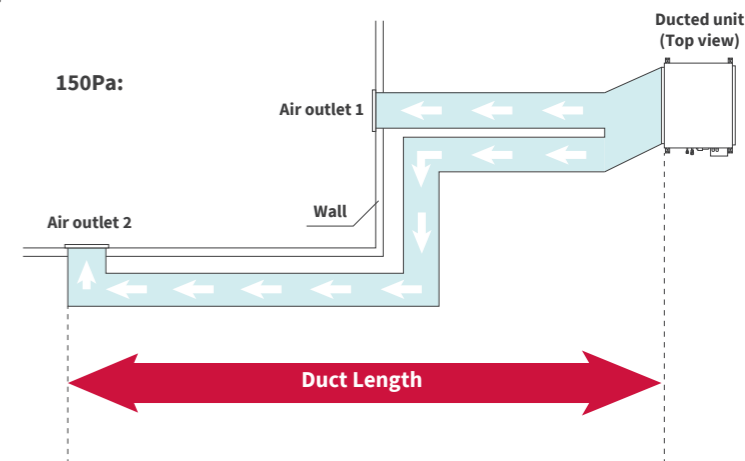

Flexible air return from bottom or rear

Two air intake options provide installation flexibility. Note: The noise of the bottom air intake is 5dB higher than the back air intake - so we recommend installing the back air intake when possible.

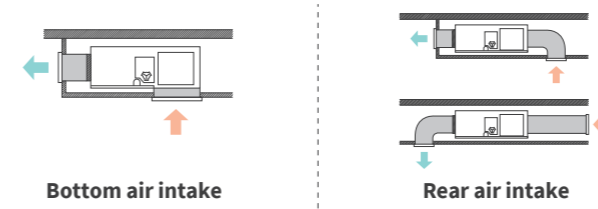

Slim Design

Slim duct unit - height of only 190mm. Applicable to RPIL-B18TFTANA, RPIM-B25TFTANA only.

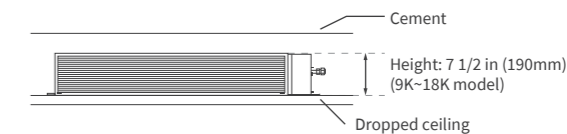

Ceiling Suspended

Small to medium-sized spaces benefit well from this slender unit. After a straightforward installation the unit blends into your interior.



HCRB31NEWH
(Standard)



HCWA21NEHH
(Optional)

The fresh air intake, fan housing and other features have all been designed for discretion, comfort and control.

FEATURES & BENEFITS

COMFORT

Fresh air inlet

Allows fresh air intake to improve indoor ventilation and air quality.

● Fresh air inlet

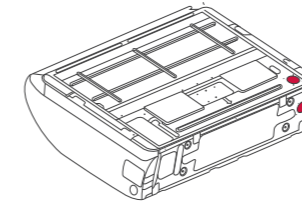

Plastic Fan housing

Plastic fan housing can reduce the noise level effectively.

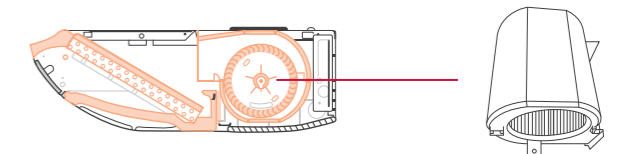

Plastic Fan housing

Comfortable airflow distribution

The horizontal and vertical air flow swing can provide better comfort.
Up to 90° up and down airflow
Up to 65° left and right airflow manually



DESIGN FLEXIBILITY

Installation on Ceiling

A unit that can function equally well after suspended ceiling installation can adapt to many different room layouts, business types or living spaces.

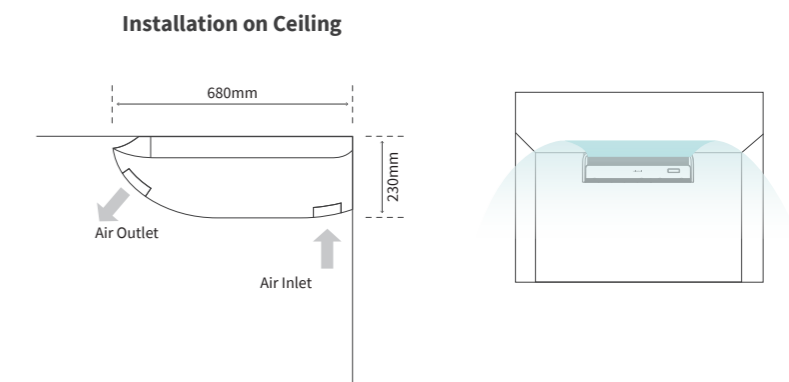

Structural rigidity

The drain pan uses an integrated design with high-strength steel and PS foam. This ensures the durability of the drain pan and improves the thermal insulation and anti-condensation properties of the unit.

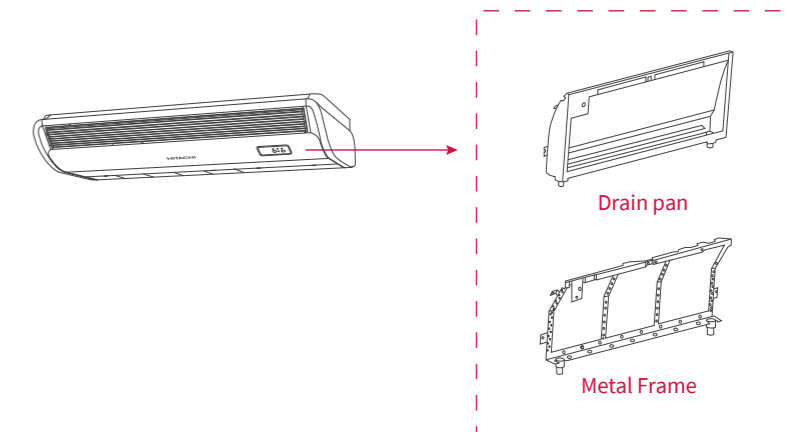



Controls

Customize your comfort with wall-mounted or handheld controls. With easy-to-read and intuitive interfaces, you'll find it's fast and simple to make your environment your own.

REMOTE CONTROL

The remote control is practical and intuitive in design with a simple button layout that allows you to control your unit instantly. The classic LCD matches the wired control point with each working feature represented in one frame. The remote operates on a single battery, using minimal power for long-lasting use.

HCRB31NEWH

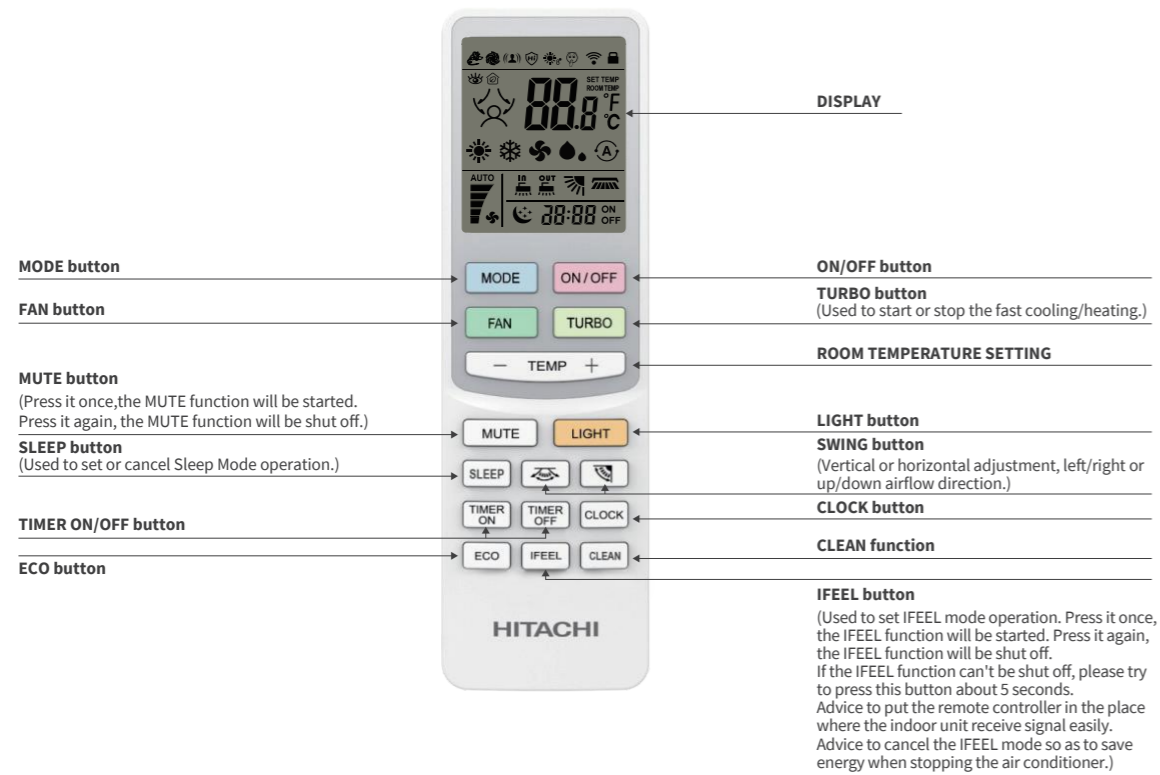

WIRED CONTROL

You can keep an eye on exactly what your system is doing thanks to the ultra-clear touchscreen display on the Wired Control Point. This is your main hub with your airCore 600 system. Selecting different modes is simple – even from the very first use, ensuring you can achieve and maintain your ideal work and living space.

HCWA21NEHH

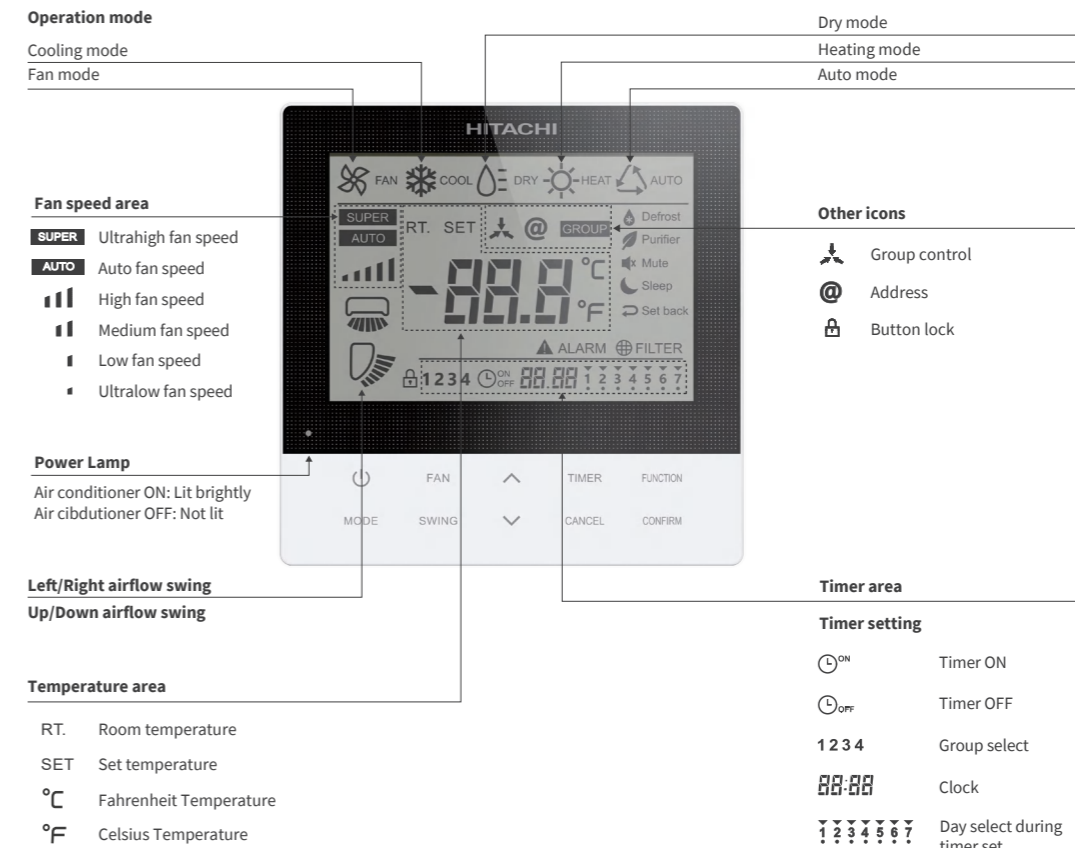

SPECIFICATIONS

CASSETTE

IDU ODU		RCI-B18TFT5NA RAS-B18TFTSNA5	RCI-B25TFT5NA RAS-B25TFTSNA5	RCI-B30TFT5NA RAS-B30TFTSNA5	RCI-B36TFT5NA RAS-B36TFTSNA5	RCI-B42TFT5NA RAS-B42TFTSMA5	RCI-B48TFT5NA RAS-B48TFTSMA5	RCI-B55TFT5NA RAS-B55TFTSMA5	
Power supply (Indoor)	V/Ph/Hz	220-240/1/50	220-240/1/50	220-240/1/50	220-240/1/50	220-240/1/50	220-240/1/50	220-240/1/50	
Power supply (Outdoor)	V/Ph/Hz	220-240/1/50	220-240/1/50	220-240/1/50	220-240/1/50	220-240/1/50	380-415/3/50	380-415/3/50	
Max. input consumption	W	1,800	3,200	3,800	4,300	5,000	6,600	6,600	
Max. input current	A	9.5	14.2	16.8	19.0	9.5	12.0	12.0	
Cooling	Capacity	Btu/h	18,500	26,000	30,400	36,000	42,000	48,000	51,000
	Capacity (range)	W	5,400(2,100-5,800)	7,600(2,500-8,000)	8,900(3,000-9,400)	10,500(3,600-11,500)	12,300(3,900-13,000)	14,000(4,400-16,000)	15,000(4,500-16,100)
	Input Power (range)	W	1,380(340-1,650)	2,000(520-2,850)	2,710(650-3,600)	3,030(800-4,000)	3,700(880-4,700)	4,900(1,000-6,300)	5,920(1,050-6,350)
	Current	A	8.1	8.9	12.0	13.4	6.5	8.6	11.0
	EER	W/W	3.91	3.80	3.28	3.47	3.32	2.86	2.53
	SEER		21.94	20.10	17.71	16.82	14.00	14.00	14.0
Indoor air flow Rated(Hi/Med/Lo)	m³/h	1,250/1,100/950	1,350/1,150/1,050	1,550/1,400/1,150	1,650/1,450/1,200	2,000/1,750/1,550	2,000/1,750/1,550	2,000/1,750/1,550	
Indoor air flow Rated(Hi/Med/Lo)	CFM	735/647/560	794/676/618	918/824/676	970/853/706	1,170/1,030/910	1,170/1,030/910	1,170/1,030/910	
Indoor sound pressure level (Hi/Med/Lo)	dB(A)	40/35/33	44/40/35	48/44/40	50/47/43	52/50/48	52/50/48	52/50/48	
Indoor unit	Dimension (WxHxD)	mm	840×236×840	840×236×840	840×236×840	840×272×840	840×272×840	840×272×840	
	Net/Gross weight	kg	23/28	23/28	23/28	26/32	27/32	27/32	
Drainage water pipe diameter	mm	ODΦ32	ODΦ32	ODΦ32	ODΦ32	ODΦ32	ODΦ32	ODΦ32	
Operation temperature	°C	16~30	16~30	16~30	16~30	16~30	16~30	16~30	
Outdoor sound pressure level	dB(A)	50	53	54	58	56	56	56	
Throttle type		EEV	EEV	EEV	EEV	EEV	EEV	EEV	
Outdoor unit	Dimension(WxHxD)	mm	810×580×280	860×670×310	860×670×310	900×750×340	900×1,170×320	900×1,170×320	
	Net/Gross weight	kg	33/37	44/48	46/50	55/59	79.0/87.5	79.0/87.5	
Refrigerant type Quantity	Type		R32	R32	R32	R32	R32	R32	
	Charged volume	kg	0.97	1.20	1.30	1.80	2.47	2.47	
Design pressure	MPa	4.3/1.6	4.3/1.6	4.3/1.6	4.3/1.6	4.3/1.6	4.3/1.6	4.3/1.6	
Refrigerant piping	Liquid side/ Gas side	mm(inch)	Φ6.35/Φ12.7(1/4'/1/2')	Φ9.52/Φ15.88(3/8'/5/8')	Φ9.52/Φ15.88(3/8'/5/8')	Φ9.52/Φ15.88(3/8'/5/8')	Φ9.52/Φ19.05(3/8'/5/8')	Φ9.52/Φ15.88(3/8'/5/8')	
	Max. pipe length	m	25	50	50	50	50	50	
	Max. difference in level	m	15	30	30	30	30	30	
Ambient temperature	Cooling	°C	-7~48	-7~48	-7~48	-7~48	-7~48	-7~48	

SPECIFICATIONS

DUCTED

IDU ODU		RPIL-B18TFTANA RAS-B18TFTSNAA	RPIM-B25TFTANA RAS-B25TFTSNAA	RPIM-B30TFTANA RAS-B30TFTSNAA	RPIM-B36TFTANA RAS-B36TFTSNAA	RPIM-B42TFTANA RAS-B42TFTSNAA	RPIM-B42TFTANA RAS-B42TFTSMAA	RPIM-B48TFTANA RAS-B48TFTSMAA	RPIM-B55TFTANA RAS-B55TFTSMAA	
Power supply (Indoor)	V/Ph/Hz	220-240/1/50	220-240/1/50	220-240/1/50	220-240/1/50	220-240/1/50	220-240/1/50	220-240/1/50	220-240/1/50	
Power supply (Outdoor)	V/Ph/Hz	220-240/1/50	220-240/1/50	220-240/1/50	220-240/1/50	220-240/1/50	380-415/3/50	380-415/3/50	380-415/3/50	
Max. input consumption	W	2,000	4,100	4,100	5,100	6,400	6,400	7,200	7,800	
Max. input current	A	10.7	18.1	18.1	22.5	28.2	11.6	12.6	14.8	
Cooling	Capacity	BTU/h	18,500	25,000	30,000	34,500	42,000	42,000	48,000	51,000
	Capacity(range)	W	5,400(2,600-5,600)	7,300(2,450-7,850)	8,800(4,000-9,500)	10,100(3,500-11,000)	12,300(3,300-13,200)	12,300(3,300-13,200)	14,000(3,200-16,000)	15,000(3,300-18,500)
	Input Power	W	1,740	2,355	3,032	3,487	4,734	4,734	5,390	5,775
	Current	A	7.7	10.4	13.5	15.5	21.0	8.1	9.3	11.0
	EER	W/W	3.10	3.10	2.90	2.90	2.60	2.60	2.60	2.60
	SEER	A	17.10	17.10	16.10	16.10	14.00	14.00	14.00	14.00
ESP	Rated	Pa	25	25	37	37	50	50	50	50
	Range	Pa	0-50	0-50	0-120	0-120	0-150	0-150	0-150	0-150
Indoor air flow Rated(Hi/Med/Lo)	m³/h	900/770/650	1,000/700/490	1,450/1,120/900	1,800/1,600/1,400	1,750/1500/1,300	1,750/1500/1,300	2,400/2,200/1,900	2,400/2,200/1,900	
Indoor air flow Rated(Hi/Med/Lo)	CFM	536/458/327	588/411/288	853/659/529	1,059/941/824	1,029/882/765	1,029/882/765	1,412/1,294/1,118	1,412/1,294/1,118	
Indoor sound pressure level (Hi/Med/Lo)	dB(A)	41/37/33	39/35/32	42/39/35	42/40/38	42/39/36	42/39/36	48/45/42	48/45/42	
Indoor unit	Dimension (WxHxD)	mm	1,180×190×447	1,180×190×447	1,140×268×720	1,140×268×720	1,300×350×800	1,300×350×800	1,300×350×800	1,300×350×800
	Net/Gross weight	kg	22.5/26.0	22.5/26.0	37.5/44.5	37.5/44.5	51.0/60.0	51.0/60.0	51.0/60.0	51.0/60.0
Drainage water pipe diameter	mm	ODΦ32	ODΦ32	ODΦ32	ODΦ32	ODΦ32	ODΦ32	ODΦ32	ODΦ32	
Operation temperature	°C	16-30	16-30	16-30	16-30	16-30	16-30	16-30	16-30	
Outdoor sound pressure level	dB(A)	51	56	51	57	62	61	59	63	
Outdoor unit	Dimension(WxHxD)	mm	810×580×280	860×670×310	860×670×310	950×840×340	950×1,050×340	950×1,050×340	950×1,386×340	950×1,386×340
	Net/Gross weight	kg	36.0/40.0	49.0/53.0	49.0/53.0	70.0/75.0	85.0/97.0	85.0/95.0	101.5/114.5	109.0/122.0
Refrigerant type Quantity	Type		R32	R32	R32	R32	R32	R32	R32	
	Amount	kg	0.97	1.40	1.45	2.00	2.50	2.50	3.00	3.40
Throttle type		EEV	EEV	EEV	EEV	EEV	EEV	EEV	EEV	
Design pressure	MPa	4.3/1.6	4.3/1.6	4.3/1.6	4.3/1.6	4.3/1.6	4.3/1.6	4.3/1.6	4.3/1.6	
Refrigerant piping	Liquid side/ Gas side	mm(inch)	Φ6.35/Φ12.7(1/4'/1/2')	Φ9.52/Φ15.88(3/8'/5/8')	Φ9.52/Φ15.88(3/8'/5/8')	Φ9.52/Φ19.05(3/8'/3/4')	Φ9.52/Φ19.05(3/8'/3/4')	Φ9.52/Φ19.05(3/8'/3/4')	Φ9.52/Φ19.05(3/8'/3/4')	
	Max. pipe length	m	30	50	50	50	50	50	50	
	Max. difference in level	m	15	30	30	30	30	30	30	
Ambient temperature	Cooling	°C	-7~48	-7~48	-7~48	-7~48	-7~48	-7~48	-7~48	

SPECIFICATIONS

CEILING SUSPENDED

IDU		RPFC-B18TFT5NA	RPFC-B25TFT5NA	RPFC-B30TFT5NA	RPFC-B36TFT5NA	RPFC-B42TFT5NA	RPFC-B48TFT5NA	RPFC-B55TFT5NA	
ODU		RAS-B18TFTSNA5	RAS-B25TFTSNA5	RAS-B30TFTSNA5	RAS-B36TFTSNA5	RAS-B42TFTSMA5	RAS-B48TFTSMA5	RAS-B55TFTSMA5	
Power supply (Indoor)	V/Ph/Hz	220-240/1/50	220-240/1/50	220-240/1/50	220-240/1/50	220-240/1/50	220-240/1/50	220-240/1/50	
Power supply (Outdoor)	V/Ph/Hz	220-240/1/50	220-240/1/50	220-240/1/50	220-240/1/50	380-415/3/50	380-415/3/50	380-415/3/50	
Max. input consumption	W	1,800	3,200	3,800	4,300	5,000	6,600	6,600	
Max. input current	A	9.50	14.20	16.8	19.0	9.5	12.0	12.0	
Cooling	Capacity	Btu/h	18,500	25,000	31,800	36,200	42,000	48,000	52,200
	Capacity(range)	W	5,400(2,000-5,800)	7,300(2,700-7,500)	9,300(3,000-9,600)	10,600(3,600-11,500)	12,300(3,700-12,800)	14,000(4,600-15,800)	15,300(4,700-15,900)
	Input Power(range)	W	1,500(340-1,700)	2,140(550-2,750)	2,910(660-3,750)	3,140(800-4,000)	4,000(900-4,700)	5,300(1,100-6,300)	6,065(1,150-6,350)
	Current	A	9.00	9.5	12.9	13.87	7.0	9.0	11.0
	EER	W/W	3.60	3.41	3.20	3.38	3.08	2.64	2.53
	SEER		18.29	18.29	18.08	17.95	14.00	14.00	14.00
Indoor air flow Rated (Hi/Med/Lo)	m ³ /h	1,000/880/780	1,200/950/800	1,500/1,200/1,000	2,050/1,600/1,400	2,200/1,900/1,600	2,200/1,900/1,600	2,200/1,900/1,600	
	CFM	590/520/460	705/560/470	882/705/590	1,205/941/823	1,294/1,117/941	1,294/1,117/941	1,294/1,117/941	
Indoor noise level	Sound pressure (Hi/Med/Lo)	dB(A)	47/44/40	48/45/41	51/46/42	53/48/45	46/48/51	46/48/51	
Indoor unit	Dimension (W×H×D)	mm	990×680×230	990×680×230	1,285×680×230	1,580×680×230	1,580×680×230	1,580×680×230	
	Net/Gross weight	kg	30/35	30/35	37/44	0.85	46/53.5	46/53.5	46/53.5
Drainage water pipe diameter	mm	ODΦ25	ODΦ25	ODΦ25	ODΦ25	ODΦ25	ODΦ25	ODΦ25	
Operation temperature	°C	16~30	16~30	16~30	16~30	16~30	16~30	16~30	
Outdoor noise level Rated (Sound pressure) Hi	dB(A)	50	53	54	58	56	56	56	
Throttle type		EEV	EEV	EEV	EEV	EEV	EEV	EEV	
Outdoor unit	Dimension (W×H×D)	mm	810×580×280	860×670×310	860×670×310	900×750×340	900×1,170×320	900×1,170×320	
	Net/Gross weight	kg	0.89	0.92	46/50	55/59	79.0/87.5	79.0/87.5	79.0/87.5
Refrigerant	Type		R32	R32	R32	R32	R32	R32	
	Charged volume	kg	0.97	1.20	1.30	1.80	2.47	2.47	2.47
		MPa	4.3/1.6	4.3/1.6	4.3/1.6	4.3/1.6	4.3/1.6	4.3/1.6	4.3/1.6
Refrigerant piping	Liquid side/Gas side	mm(inch)	Φ6.35/Φ12.7(1/4'/1/2')	Φ9.52/Φ15.88(3/8'/5/8')	Φ9.52/Φ15.88(3/8'/5/8')	Φ9.52/Φ15.88(3/8'/5/8')	Φ9.52/Φ15.88(3/8'/5/8')	Φ9.52/Φ15.88(3/8'/5/8')	
	Max. pipe length	m	25	50	50	50	50	50	
	Max. difference in level	m	15	30	30	30	30	30	
Ambient temperature	Cooling	°C	-7~48	-7~48	-7~48	-7~48	-7~48	-7~48	