

PRIMAIRY

LARGE SINGLE SPLIT INVERTER SERIES | HEAT PUMP

jci air

Johnson Controls - Hitachi Air Conditioning

ADDRESS

New Pier Takeshiba South Tower
1-16-1, Kaigan Minato-ku, Tokyo 105-0022, JAPAN
Tel: +81-3-6721-5567
www.jci-hitachi.com

HITACHI. CERTIFIED QUALITY



Eurovent certified performance:
Johnson Controls Hitachi participates in the Eurovent
Certified Performance programme for AC.
Check ongoing validity of certificate:
www.eurovent-certification.com

The specifications of this catalog may change without prior notice to allow Hitachi Cooling & Heating to incorporate the latest innovations for its customers. The information contained in this catalog is merely informative. Hitachi Cooling & Heating declines any responsibility in the broadest sense, for damage, direct or indirect, arising from the use and / or interpretation of the recommendations in this catalog.

Find the products Hitachi Cooling & Heating with the best service and conditions at your Hitachi Distributor.

UFESNH1-C-1911



Cooling & Heating



INDEX

06 Welcome

12 Connecting With You

16 Introducing PRIMAIRY

18 Applications

20 General Features

32 Indoor Units

40 Control Systems

44 Specification Tables

Living

Harmony

Welcome



Air. It's a wonderful thing

Invisible, silent and life-giving, air makes our entire world possible. It surrounds us, continuously energizing, cooling and warming. It can be unpredictable and sometimes challenging, but when air is in harmony with us, everything seems that much easier.

This is our vision.
To create the air that makes life better.

The beauty of balance

No matter what the weather is like outside, when you're indoors, you want to have complete control over your environment. At work or play, awake or asleep, you're free to create your own atmosphere; balancing energy with calm, sound with silence and light with shade. It's the same for cooling and heating.

When the air around you is in balance, you can enjoy life indoors that much more.





Living Harmony

At Hitachi Cooling & Heating we like to think of this as creating harmony with your interior environment. When we achieve that wonderful balance, productivity, learning, happiness and health can thrive.

We call this 'Living Harmony' and it's at the center of everything we do.

We live & breathe innovation

Since 1952, Hitachi's Cooling & Heating technology has been helping make life more harmonious for people around the world. Today, our long heritage of precision Japanese engineering ensures that no detail is overlooked in our quest to create Living Harmony.



The future together

Living Harmony puts people first. By balancing the human needs of our customers with an uncompromising approach to innovation and quality, we can continue to create the technologies for a more comfortable and balanced world.

Your world. We live in it together.



Your world

**We live in it
together**

Connecting with you

Reaching out

Finding the right appliances can be tricky. PRIMARYY is an air-conditioning system that was created to become a part of your long-term surroundings.



PRIMARYY units integrate smoothly into your daily life, improving the experience for everyone involved with your business. Our range is especially adapted for places such as shops, restaurants, cafés, creative studios, galleries, workshops and classrooms.

At your service

Your environment will always be filled with fresh air, at the temperature needed, with a minimum of effort or irritation.

Our aim is to bring greater comfort to your working days and to your customers' visits to your store, office or workspace.



Made for you

Each component of your new system will arrive ready for rapid installation and operation. Units not only combine advanced software and hardware design, they are assembled with passion. Every unit undergoes rigorous testing before it is shipped. Climates may vary, but whether it is cold or hot, PRIMARYY can withstand harsh weather and general wear and tear.

Our adjustable ESP (External Static Pressure) design ensures that all air vents provide cool or heated air evenly and reliably. To accommodate your space, flexible piping and a comprehensive capacity range are available. When facing a unit malfunction, error codes will be clearly displayed to facilitate maintenance. There is always a PRIMARYY solution suited to your needs.





Your loyal partner

Assisting you by improving the temperature and quality of air in your workspace is our role as a partner. An integral element of this is durability.



Customers from across the globe have voiced concerns to us in the past about their systems' ability to resist deterioration. In the development of PRIMARY, safeguard devices have been added to limit damage, including sensors, special coatings and sturdy surfaces.

Striving for perfection

A set of strong beliefs and practices at Hitachi have paved the way for generations of efficient products. PRIMARY represent the culmination of much collective effort, giving the series a great advantage – and making PRIMARY the right way to go, for you, your employees and your customers.



Introducing PRIMAIRY

PRIMAIRY's aims

PRIMAIRY is an air system series made to cope with the foremost daily needs of small business owners and people living and working in small to medium-sized spaces around the world. The name 'PRIMAIRY' signifies the goal of addressing the 'Primary' needs of people in terms of giving them access to cleaner, consistently modified air in their environments.

Some features may not apply to the units sold in your country.



48°C

High ambient cooling

Strong cooling for high ambient temperatures, enabling delivery of reliable cooling to users who require consistent resistance to high levels of natural heat. System is designed for temperatures of up to 48°C.

30%

Maintains 30% refrigerant level

Ensures the strong performance of the refrigerant circulation components. When the refrigerant volume is less than 30%, the unit automatically registers this and displays the relevant fault code, prompting users to maintain the system.

16 steps

Multiple steps of adjustment (Only Inverter type)

Quiet operation is a must. The outdoor DC motor has 16 steps of automatic adjustment to reduce fan speed and frequency of movement, leading to reduced noise.

50m

Extended height and length

Up to 50m in pipe length can be covered when the unit is being installed, and up to 30m in height, depending on your needs.

Reliable partners for small businesses

The need for a comfortable and quiet environment as the basis for a small business to thrive. Reliability, adaptability to each physical setting and precise control for users are the technical priorities of PRIMAIRY.

Diligent manufacturing

Stable operation of key equipment like the compressor, in typical and extreme temperatures, the inclusion of auto restart after power failure and self-diagnosis of faults are all the result of improvement and application of research. The careful design and continuous support in maintenance of machines indicates how much we care about ensuring comfort in your space.

Design for different spaces

Different indoor machines can be matched with different spaces to meet the desired level of control, upkeep and comfort. Users also decide how their system will fit into their space aesthetically.

Your need is our motivation

Your requirements for setting up a harmonious space for working and living are our central concern. Based on previous breakthroughs as well as plenty of updated studies, we have assembled a series that targets the core needs shared by global users, while coming equipped to adapt to the personal wishes of each individual owner, no matter how their space is laid out.

Your spaces & PRIMARY

PRIMARY is prepared to take care of the air around you. You, your colleagues and customers deserve to feel comfortable in every situation. This means finding and installing the ideal unit for your particular interior, a process we will be happy to help with. We will also help you run your unit correctly and intervene when repair is needed.



“Having a comfortable setting is essential. The air-conditioning system that management installed is a big part of this.”

Restaurant & Café



“Running a café means noise, buzz, activity and trapped heat. Having a correct and consistent A/C lets my customers relax and enjoy their drinks – and I can see the difference in their moods.”

Retail Space



“I work with clothes, and the fabric can heat up in summer and make things stuffy. The store is cold in winter. Without the system to regulate things all year round, the seasons would really get to me.”

Small Work Space



“I stay late at the office along with my colleagues if there is a big project to finish. Having a comfortable setting is essential, and the airflow system that management installed is a big part of this.”

They might not know each other, but we know them: A community of customers around the world is connected by hard work and a commitment to a harmonious environment. We inside Hitachi will always strive to support them.





General Features

Features, advantages and benefits

PRIMARY includes all required for selection, installation and maintenance, making it the perfect choice for small businesses and workplaces, as well as other interior spaces. When in use, PRIMARY responds sensitively to air temperature and maintains it at the desired level, using just the right amount of energy.

COMFORT & RELIABILITY

Enjoy an improved environment with one of the three main models of PRIMARY. Once your space is transformed, you will get used to a much greater level of reliable comfort and convenience.

EXPANSION INTERFACE

The interface enables connection to a smoke detector, key slot or other device.

- Reserved port for fire alarm device
- Reserved port for key slot

For example: Hotel key card systems, where guests can insert their room's key card to use power.

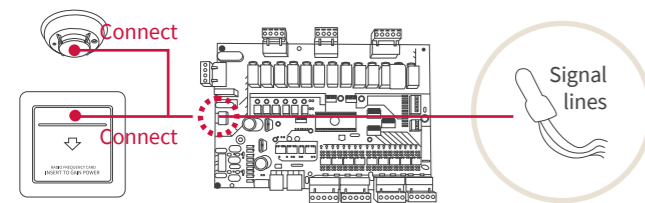

ERROR SELF-DIAGNOSIS FUNCTION

The error code is clearly displayed on the diagnostic panel of the outdoor unit for quick troubleshooting and maintenance.

OUTDOOR UNIT ERROR CODE DISPLAY

ON/OFF UNITARY TYPE

(with outdoor control box)

There are two ways an error is displayed: in digits or via a flashing indicator light on an outdoor control board. Based on the digits or the amount of times the light flashes, various faults are represented.

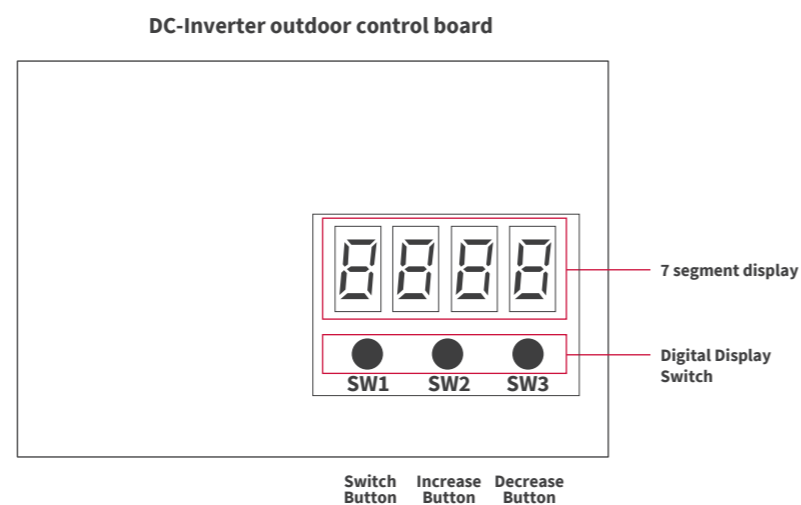

It can be used to check outdoor running parameters.



MULTI-SPEED FAN (INDOOR UNIT)

A multi-speed fan helps satisfy various airflow requirements.

AUTO RESTART

Units are automatically returned to previous operation conditions after a power outage, for simplified operation.

QUIET OPERATION

Units have a quiet mode that reduces the fan speed and the frequency of the compressor, resulting in a low operation noise, keeping your family and neighbors content.

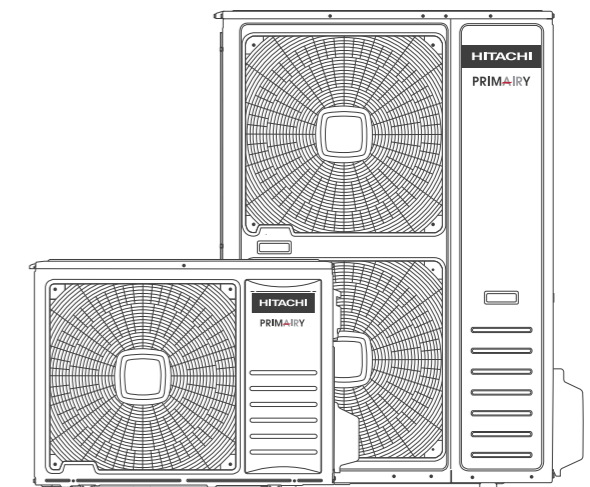
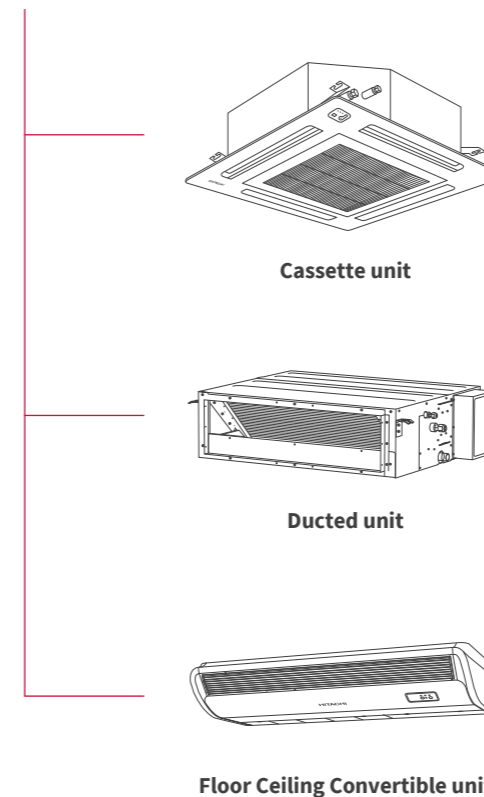

EFFICIENCY

Sustained testing, engineering and design have created air conditioners that are very well suited to keeping their core functions running. The outdoor unit can endure a wide temperature range and regulates its own response to freezing.

EFFICIENCY RATIO

Ducted unit

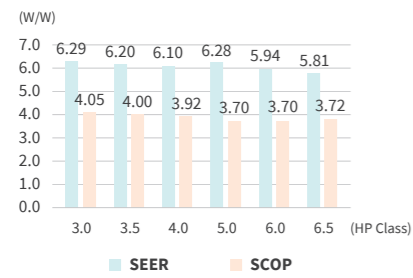

Cassette unit

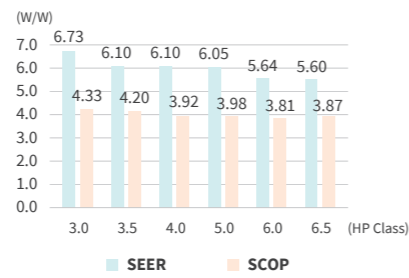

Floor ceiling convertible unit

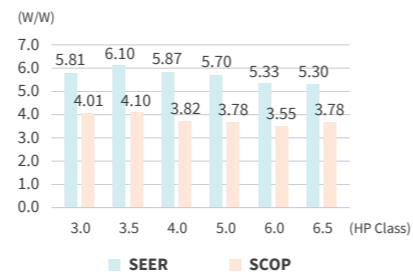

HIGH EFFICIENCY DC FAN MOTOR

Most of the fan motors of indoor and outdoor units are DC fan motors, which can adjust speed and ESP automatically. This makes the running of the units more reliable and efficient with low noise.

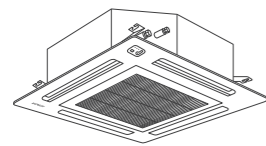

Cassette unit

Unit	3.0HP	3.5HP	4.0HP	5.0HP	6.0HP	6.5HP
Fan motor	DC	DC	DC	DC	DC	DC

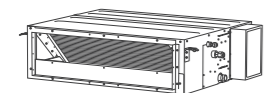

Ducted unit

Unit	3.0HP	3.5HP	4.0HP	5.0HP	6.0HP	6.5HP
Fan motor	DC	DC	DC	DC	DC	DC

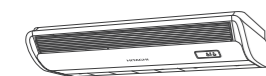

Floor Ceiling Convertible unit

Unit	3.0HP	3.5HP	4.0HP	5.0HP	6.0HP	6.5HP
Fan motor	DC	DC	DC	DC	DC	DC



WIDE AMBIENT TEMPERATURE RANGE

High cooling and heating performance within a wide ambient temperature range.

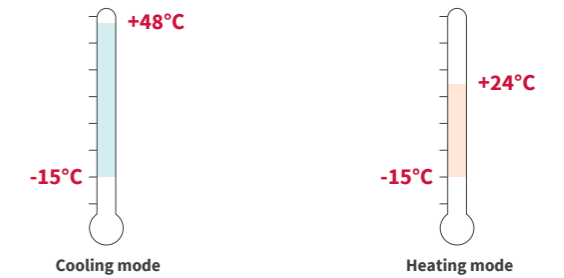

GENERAL FEATURES

HIGH EFFICIENCY FIN HIGH EFFICIENCY HEAT EXCHANGER

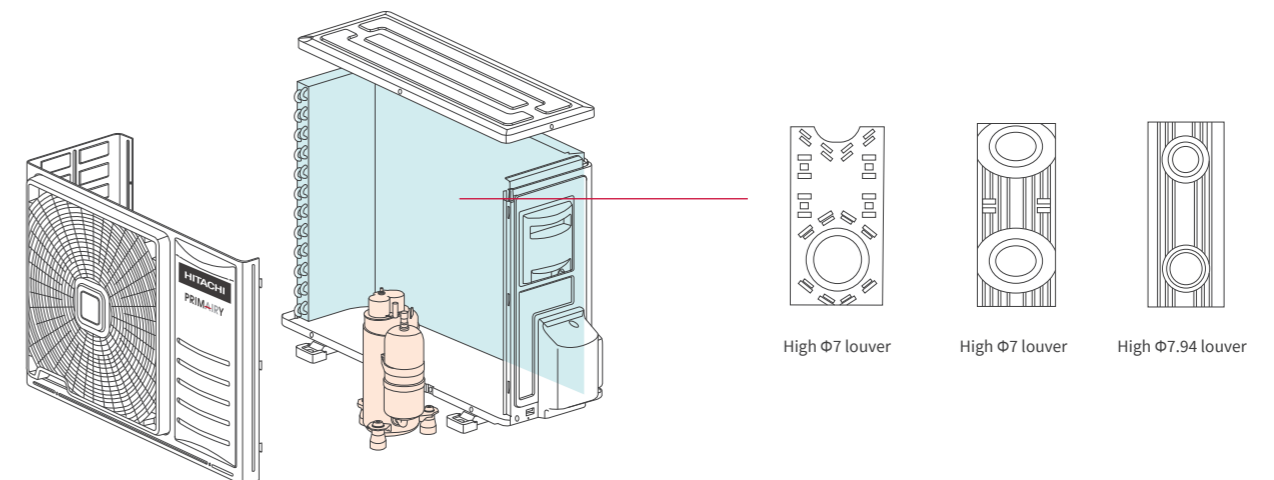

SMART DEFROST

The smart defrost software and added defrost sensor will precisely control the defrost time and effect, which can effectively avoid the defrost delay.

EFFICIENCY

Being eco-friendly by applying R32 Refrigerant

To minimize F-Gas emission, Hitachi applies R32 refrigerant in this series which helps to reduce GWP (Global Warming Potential) by 2/3 while ODP (Ozone Depletion Potential) is 0.



Global warming potential (GWP) comparison:

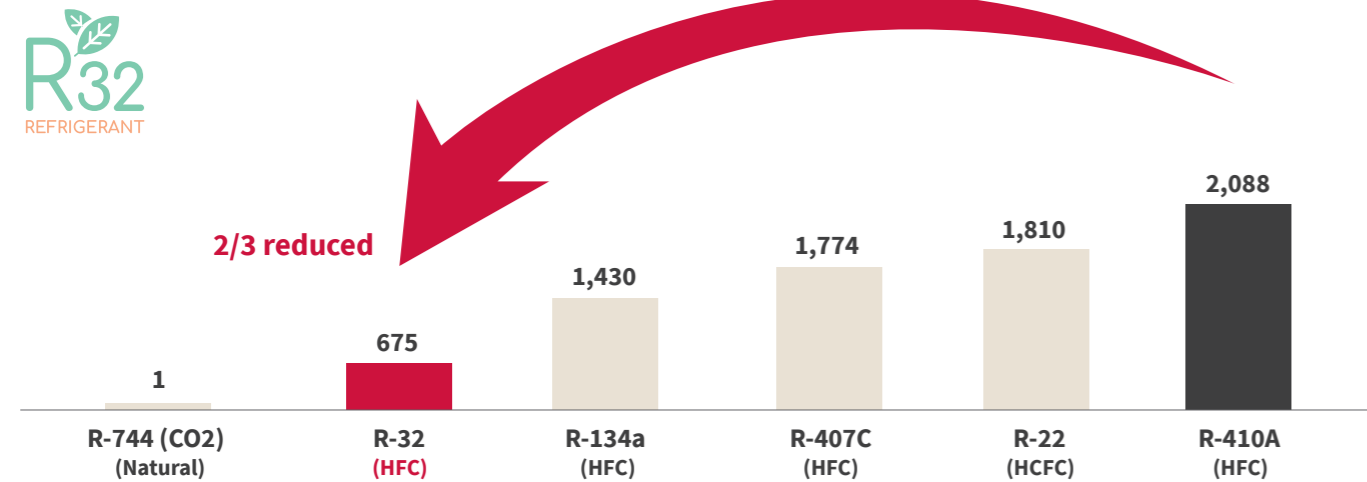

The volume is 43% compacted
The height is 30% reduced

Height: **30% reduced**

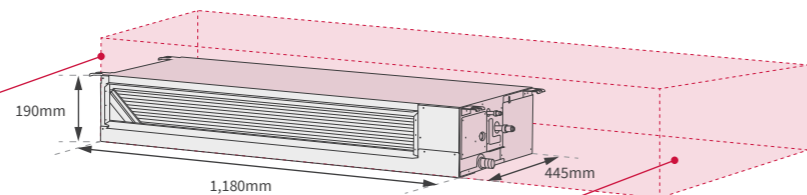

Volume: **43% compacted**

IMPROVED ENERGY EFFICIENCY

Ducted unit (3.0HP)

* Best efficiency among the industry.

SEER (W/W)

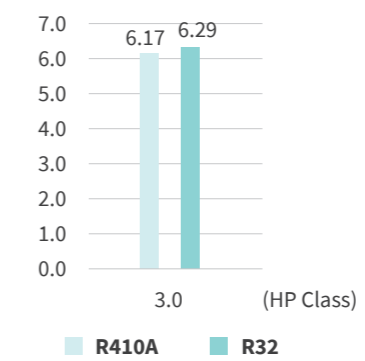

SCOP (W/W)

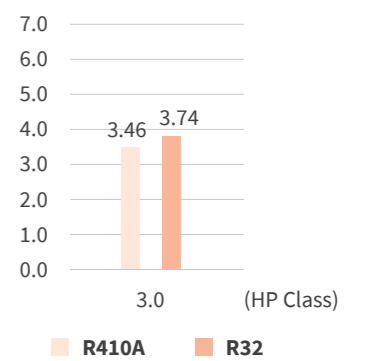

Cassette unit (3.0HP)

SEER (W/W)

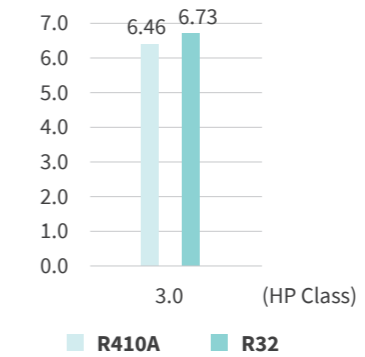

SCOP (W/W)

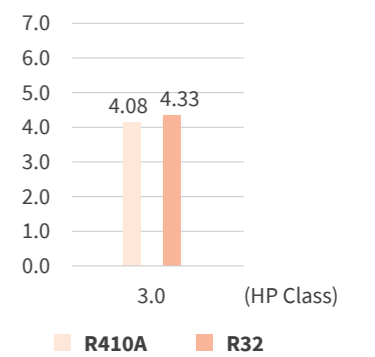

GENERAL FEATURES

RELIABILITY

How to know when a product is truly safe? When it is hardly ever necessary to check it. Each key area requiring a failsafe feature has been thoroughly researched and a dependable solution incorporated. Where possible, Hitachi air-conditioning units are self-diagnosing when it comes to errors. Physical protection is combined with sensors for a system of smooth operation and security.

SAFETY PROTECTION

An encompassing metal box design ensures full product safety.

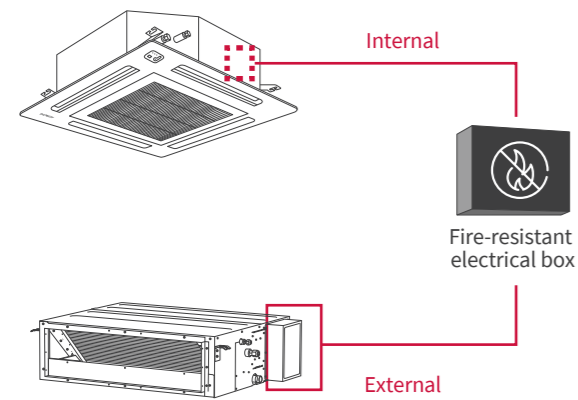

LOW/HIGH PRESSURE SWITCH

High pressure and Low pressure switches keep the system and compressor reliable.

Comments:
For Inverter series, there's no LP&HP switch for 3.0HP and no LP switch for 4.0HP.

TEMPERATURE PROTECTION SYSTEM

- Fan motor overheating protection
- Compressor overheating protection
- Compressor starts preheating in cold climate
(Only for Heat Pump)

DISCHARGE TEMPERATURE SENSOR

Ensures the compressor will operate in the safety range, and prevent the damage caused by refrigerant leakage.

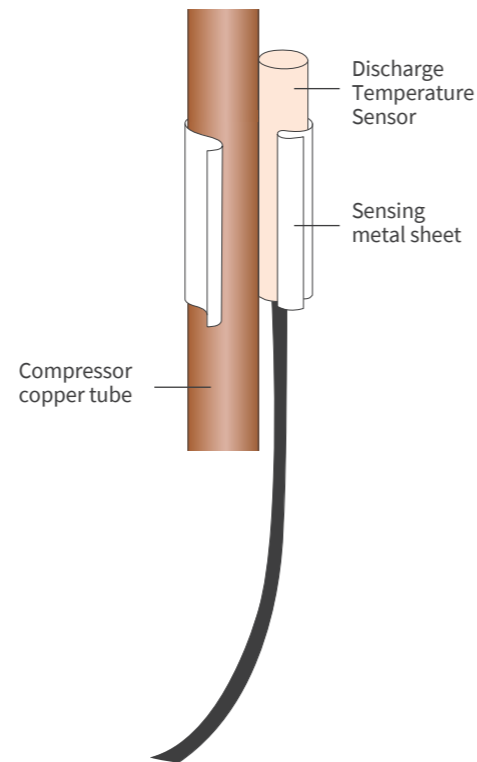

RELIABLE RUNNING

Oil viscosity testing was taken for compressor in order to ensure reliable operation.



REFRIGERANT LEAKAGE DETECTION

The indoor unit will stop operation automatically and show an error code when the refrigerant charging amount is lower than 30%, which can avoid the compressor being damaged by high temperature due to refrigerant leakage. When the refrigerant charging amount is between 30%~80%, the unit will judge itself if showing an error code is necessary. This feature can also better ensure the heat transfer efficiency and the safety of the unit.

HYDROPHILIC ALUMINUM FIN

A hydrophilic aluminum fin enhances heat exchanging performance by increasing water mobility on fin surface and preventing water droplets from forming blockage between fins. The blue coating enhances protection from corrosion resulting from environmental and microbiological factors, increasing reliability and ensuring performance.

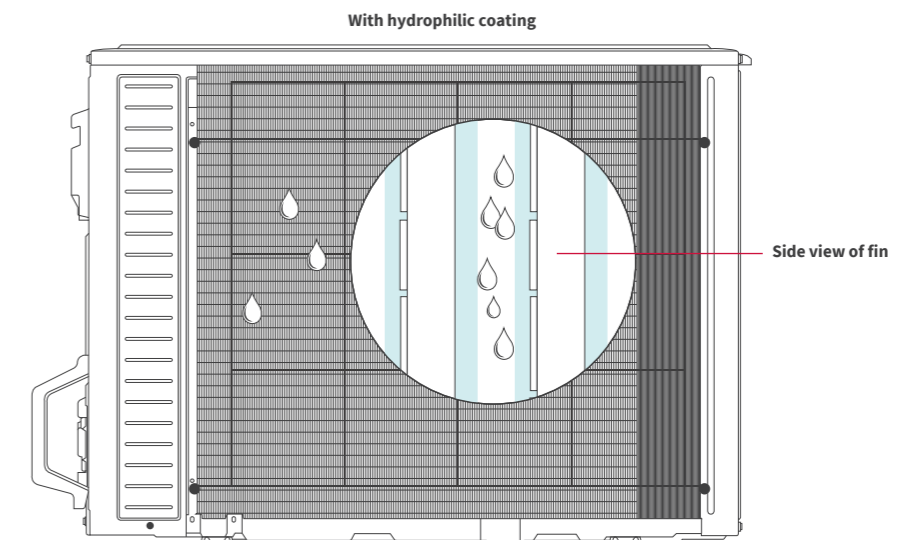

The coating prevents water droplets collecting on the fins and causing blockages.

DESIGN FLEXIBILITY

EASIER HANDLING OUTDOOR UNITS

As with every other important variable in setting up your PRIMARY system, there are multiple alternatives available for the outdoor unit. Each one is modular and straightforward to fix into place. We will assist you in each key phase of installation as you set up your system.

COMBINATION OF MODULES

RAS-3.0 UFESNH1
RAS-3.5 UFESNH1

Dimension (W×H×D)
860×670×310mm
HP Class
3.0 - 3.5



RAS-4.0 UFESNH1

Dimension (W×H×D)
950×840×340mm
HP Class
4.0

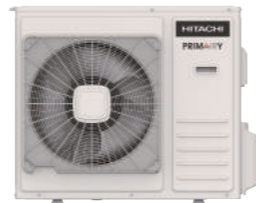

RAS-5.0 UFESMH1

Dimension (W×H×D)
950×1050×340mm
HP Class
5.0



RAS-6.0 UFESMH1
RAS-6.5 UFESMH1

Dimension (W×H×D)
950×1386×340mm
HP Class
6.0 - 6.5



MORE FLEXIBLE PIPING

Both short and long piping may be applicable to the installation needs of different sites. The right placement of the indoor unit is key to distributing the air properly.

Long piping and large height difference

Up to 50m in piping run and 30m in height can be covered, with great overall flexibility in installation.

Piping	HP	3.0	3.5	4.0	5.0	6.0	6.5
Diameter (Liquid)	Inch	3/8	3/8	3/8	3/8	3/8	3/8
Diameter (Gas)	Inch	5/8	5/8	3/4	3/4	3/4	3/4
Max Length	m	30	50	50	50	50	50
Max Height	m	15	30	30	30	30	30

— Liquid pipe
— Gas pipe

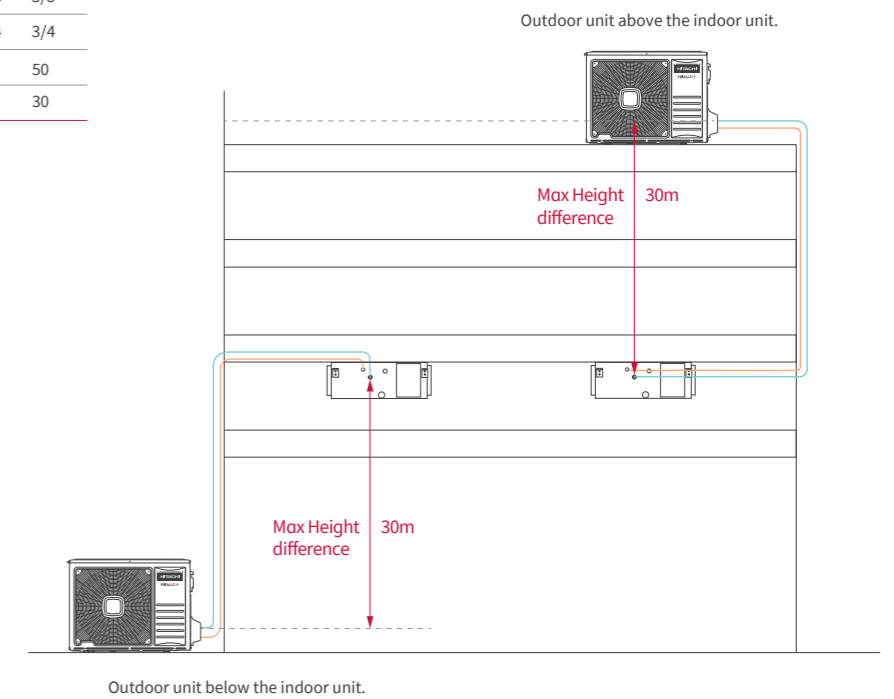

COMPACTNESS AND LIGHTNESS

Free of unnecessary or weighty components, each unit can be carefully slid into place by the installation team.

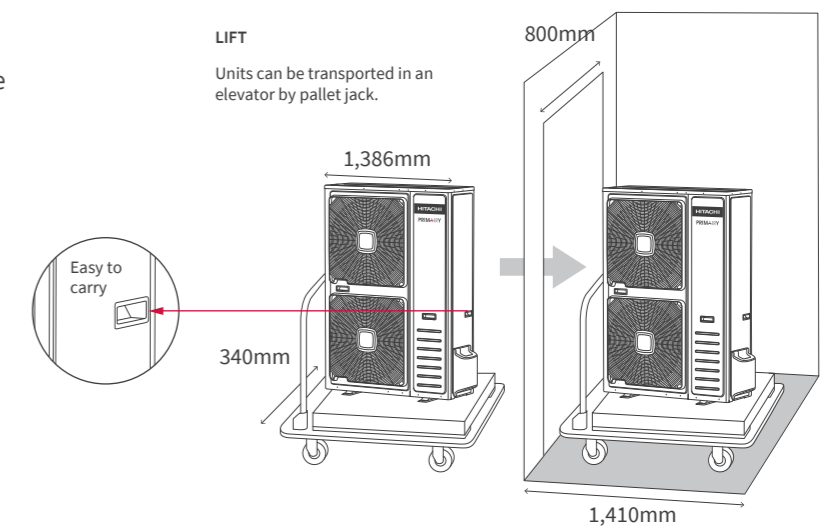









Indoor Life

Air moves within your interior spaces, making living and working more comfortable. The balanced design of the indoor units is key to making them unobtrusive, reliable and ultra-efficient. The Indoor unit's flexibility solves users' difficulties in conditioning their spaces, creating a comfortable environment for people to focus on their work or their business.

LINE-UP OVERVIEW

Indoor Unit Category

	HP (Class)	3.0	3.5	4.0	5.0	6.0	6.5
Ducted unit (W×H×D)	 1180×190×445	•					
	 1140×268×720		•	•			
	 1300×350×800				•	•	•
Cassette unit (W×H×D)	 840×248×840	•	•	•			
	 840×298×840				•	•	•
Floor Ceiling Convertible unit (W×H×D)	 990×230×680	•					
	 1285×230×680		•	•			
	 1580×230×680				•	•	•

FREEDOM OF CHOICE

Which unit or units should you choose?

There may be more than one good option, but you should take a little time to find the one that works best for you. Within the category of PRIMARY, there are three main units: Ducted, Cassette, and Floor Ceiling Convertible.

Fresh Air Inlet

Fresh air from outside can be led into the room, which keeps the room air pleasantly ventilated. (Optional)



Disclaimer
Please note that the features and options listed above must be ordered in addition to your indoor unit.

CASSETTE

FEATURES & BENEFITS



HCRA31NEWH
(Standard)



HCWA21NEWH
(Optional)



Cassette units are especially suited to narrow ceiling cavities or high ceilings. They fit to a standard ceiling grid and can be easily incorporated between light panels and other overhead fixtures.



COMFORT

Control air flow with individual 4-Way louvers

Louvers are adjustable for horizontal or vertical airflow. Smooth airflow can be directed towards every corner of the room – or even a particular point for better comfort.

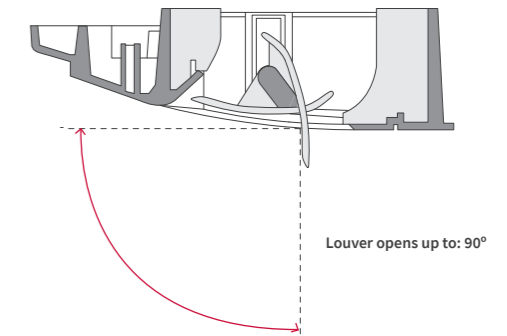
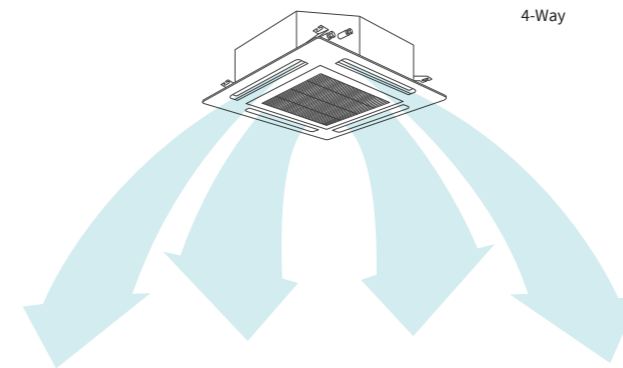

Temperature compensation

Cassette bring temperature compensation setting by wired controller. This function can revise this temperature difference to make a more accurate temperature control.

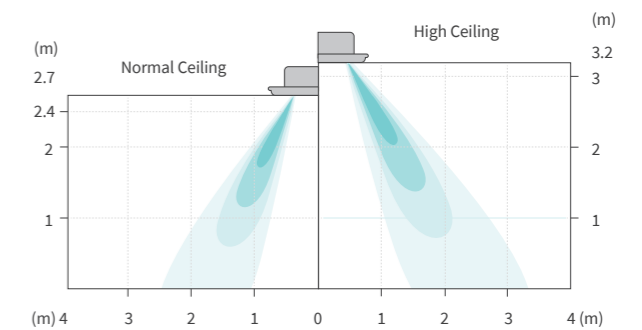

DESIGN FLEXIBILITY

Infrared Receiver for Remote Controller

Reserved port for Remote sensing which makes control more convenient.

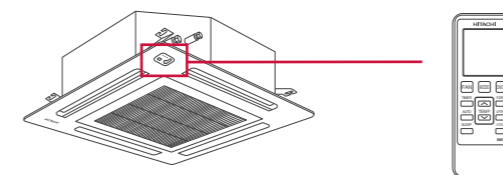

Washable Filter

A washable filter allows for cost-saving maintenance.

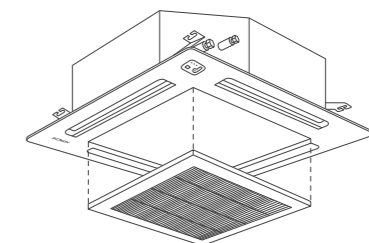

DUCTED

FEATURES & BENEFITS



HCWA21NEWH
(Standard)



HCRA31NEWH
(Optional)



The efficient design makes the Ducted unit especially discreet. Ducted units can be installed in multiple points to thoroughly aerate each part of a space.



COMFORT

Durable Protection Drainage System

The special design of the drain pan makes condensation water flow smoothly without water leakage, and prevents rust.

When the drain pipe is clogged and the water rises to a certain level, the water level switch will float and send the signal to turn off the unit.

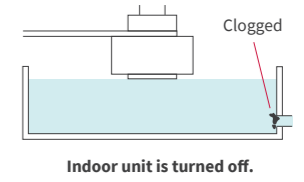
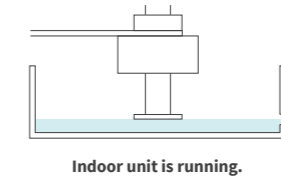

Built-in drain pan

Compared with outside drain pan design, the new built-in drain pan can reduce dust adhesion, and avoid water leakage.

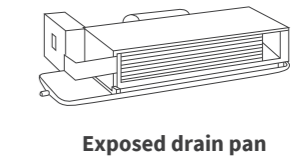
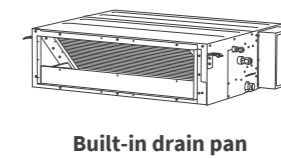

DESIGN FLEXIBILITY

Wide ESP range

A wide ESP range means PRIMARY is suitable for spaces with many discrete areas, including corners and recesses. Multiple outlets can be connected to the ducted unit to ensure a uniform gust of air around a complex space. A system can be set up in a short time and will run reliably into the future.

For example:

60Pa:

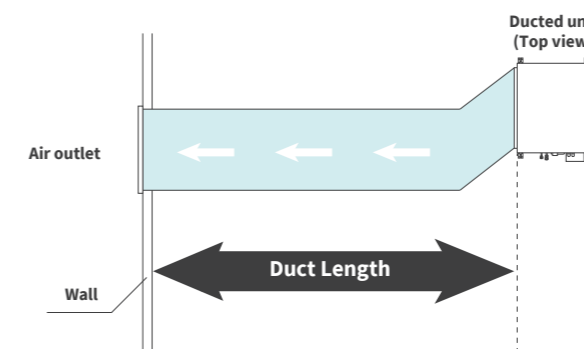

120Pa:

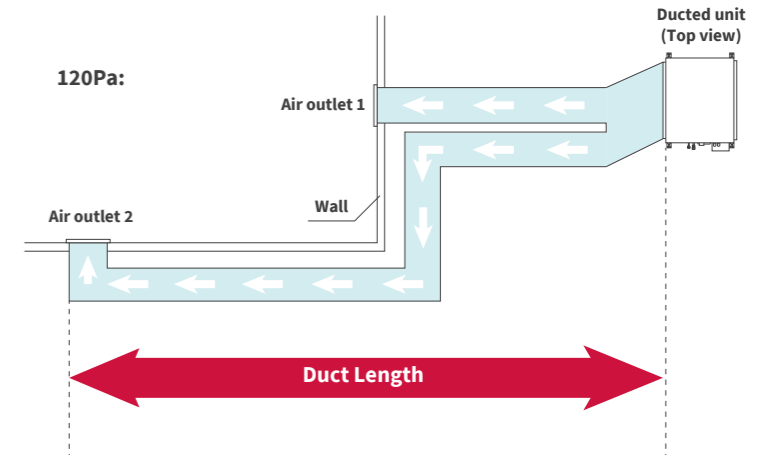

Flexible air return from bottom or rear

Depending on different space layout, the installation will be highly flexible.

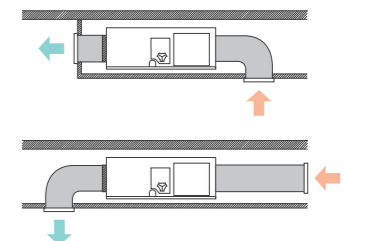
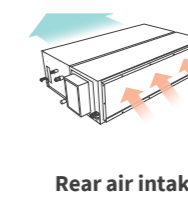
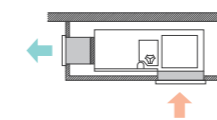

FLOOR CEILING - CONVERTIBLE FEATURES & BENEFITS



HCRA31NEWH
(Standard)



HCWA21NEWH
(Optional)



Small to medium-sized spaces benefit well from this slender unit. After a straightforward installation the unit blends into your interior. The fresh air intake, fan housing and other features have all been designed for discretion, comfort and control.



COMFORT

Fresh air inlet

Allows fresh air intake to improve indoor ventilation and air quality.

- Fresh air inlet

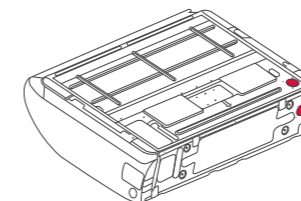

Plastic Fan housing

Plastic fan housing can reduce the noise level effectively.

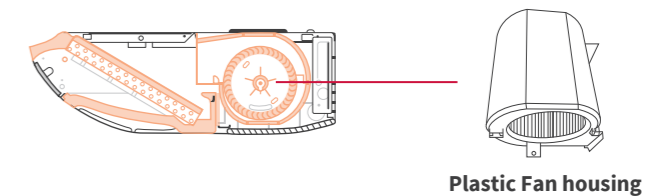

DESIGN FLEXIBILITY

Installation on Floor or Ceiling

A unit that can function equally well after floor installation or suspended ceiling installation can adapt to many different room layouts, business types or living spaces.

Installation on Floor

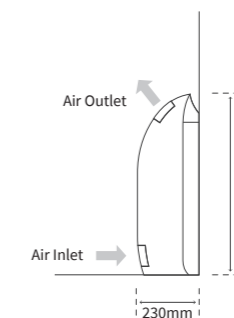

Installation on Ceiling

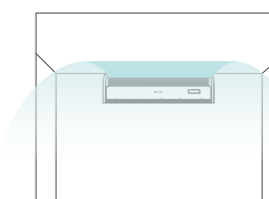
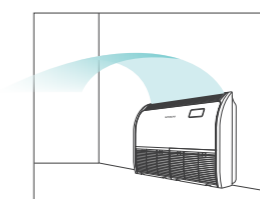
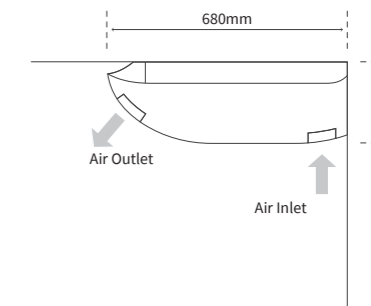

Metal frame of drain pan

The drain pan uses an integrated design with high-strength steel and PS foam. This ensures the durability of the drain pan and improves the thermal insulation and anti-condensation properties of the unit.

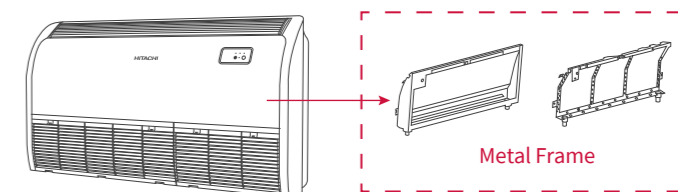



— Controllers

Selecting temperature range and other options on your PRIMARY device is crucial to a good experience. The simple interface and dependable functions in the wall-mounted and handheld controls make assigning the correct settings easy.

REMOTE CONTROLLER

The remote control is practical and intuitive in design, with a simple button set that allows you to control your unit instantly. The classic LCD display matches the wired control point, with each working element represented in one frame. The remote uses a minimum amount of power, running on a single battery for a long period, before requiring a replacement.

HCRA31NEWH

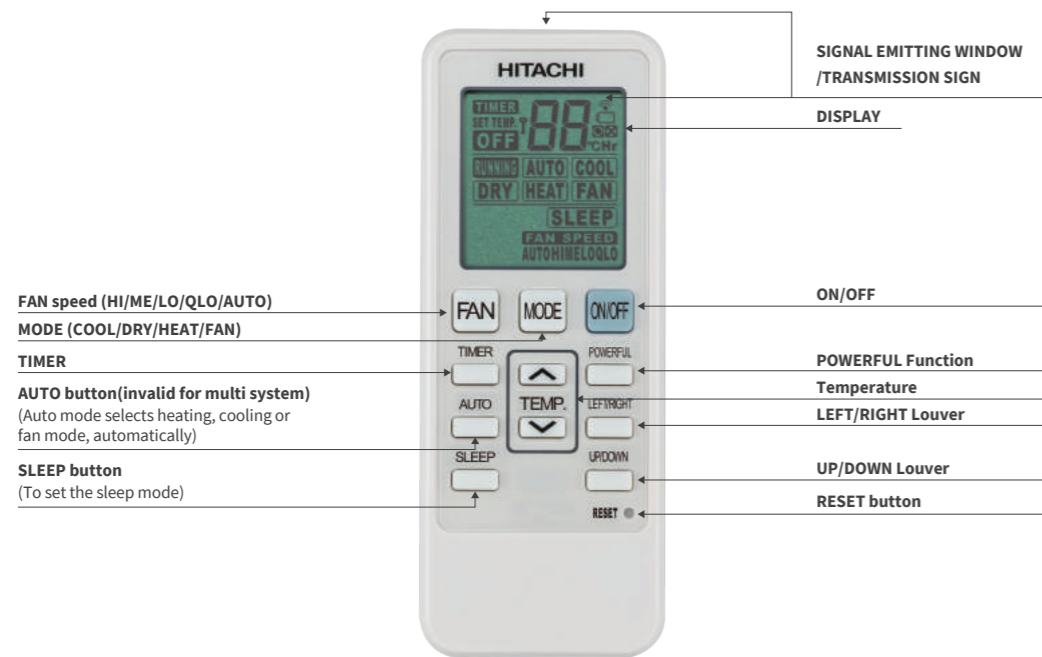

WIRED CONTROLLER

You can keep an eye on exactly what your system is doing thanks to the ultra-clear touchscreen display on the Wired Control Point. This is your main interaction point with your PRIMARY system, so it is thankfully easy to use from the first try onwards. Choose the temperature, fan speed and timing for your system to ensure an ideal working and living space.

HCWA21NEWH

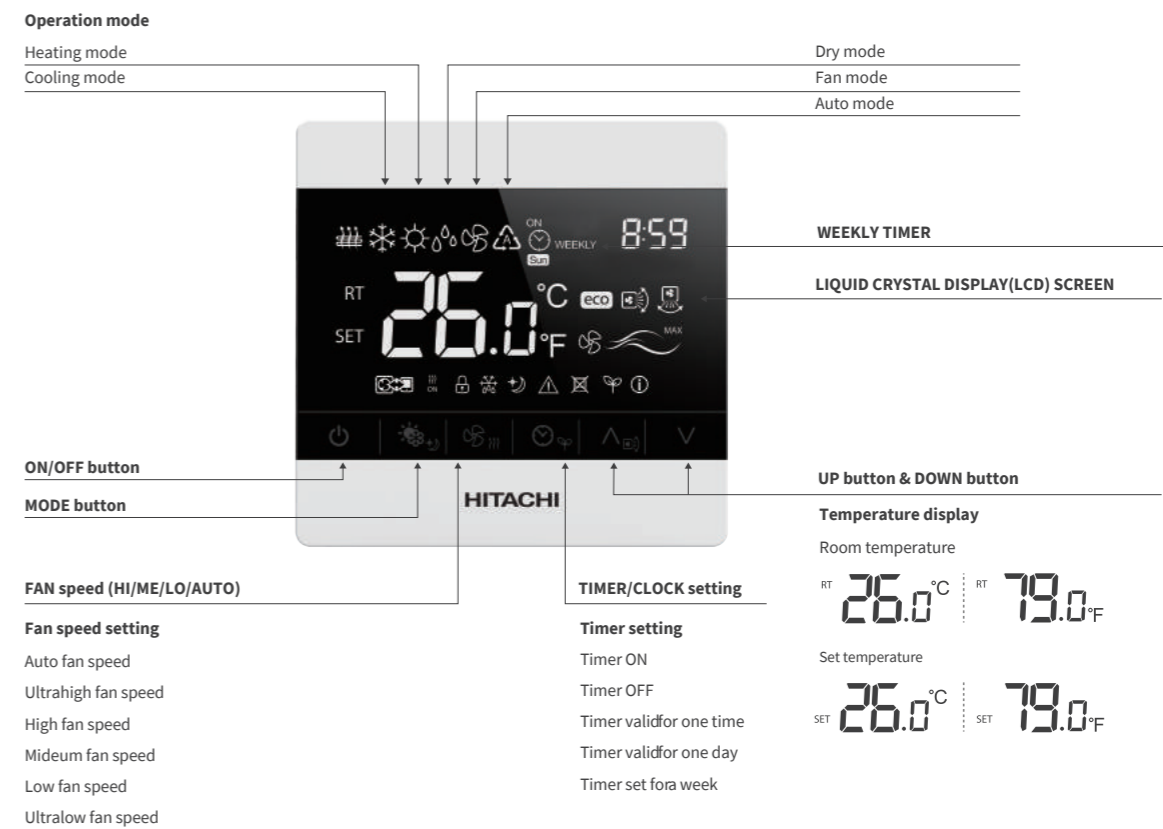



— Specifications

On the following pages you will find the full breakdown of technical specifications for the PRIMARY range.

SPECIFICATIONS

CASSETTE

IDU		RCI-3.0UFE1NH	RCI-3.5UFE1NH	RCI-4.0UFE1NH	RCI-5.0UFE1NH	RCI-6.0UFE1NH	RCI-6.5UFE1NH
ODU		RAS-3.0UFESNH1	RAS-3.5UFESNH1	RAS-4.0UFESNH1	RAS-5.0UFESMH1	RAS-6.0UFESMH1	RAS-6.5UFESMH1
Power supply (Indoor)	V/Ph/Hz	220-240/1/50	220-240/1/50	220-240/1/50	220-240/1/50	220-240/1/50	220-240/1/50
Power supply (Outdoor)	V/Ph/Hz	220-240/1/50	220-240/1/50	220-240/1/50	380-415/3/50	380-415/3/50	380-415/3/50
Max.input consumption	W	4,100	4,100	5,100	6,400	7,200	7,800
Max.input current	A	18.1	18.0	22.5	11.6	12.6	13.1
Average (Cooling)	Pdesignc	kW	7.00	8.70	10.10	12.10	16.90
	SEER	W/W	6.73	6.10	6.10	6.05	5.64
	ηs,c	100%	-	-	-	239%	223%
	Energy Efficiency Class		A++	A++	A++	-	-
	Annual energy consumption	kWh/a	388	511	580	757	894
Average (Heating)	Pdesignh	kW	6.00	7.20	8.20	9.50	13.50
	SCOP	W/W	4.33	4.20	3.92	3.98	3.81
	ηs,c	100%	-	-	-	156%	149%
	Energy Efficiency Class		A+	A+	A	-	-
	Annual energy consumption	kWh/a	1,907	2,423	3,018	3,675	5,086
Cooling	Capacity (Rated)	kW	7.00	8.70	10.10	12.10	13.89
	Capacity (Range.Min-Max)	kW	2.40-7.85	4.00-9.50	3.50-11.00	3.30-13.20	3.40-16.20
	Input	kW	1.91	2.71	3.72	4.24	4.81
	Current	A	8.5	11.8	16.8	7.4	8.7
	EER	W/W	3.66	3.21	2.72	2.85	2.89
Heating	Capacity (Rated)	kW	8.25	9.00	11.20	13.50	16.53
	Capacity (Range.Min-Max)	kW	2.10-8.80	3.50-9.50	3.32-12.00	3.00-14.60	3.70-18.00
	Input	kW	2.03	2.25	3.50	3.70	4.71
	Current	A	9.00	9.80	16.00	6.50	8.40
	COP	W/W	4.06	4.00	3.20	3.65	3.51
Indoor unit	Dimension (W×H×D)	mm	840×248×840	840×248×840	840×248×840	840×298×840	840×298×840
	Weight (Net/Gross)	kg	25/34	27/36	27/36	32/41	32/41
	Air Volume (Hi/Med/Lo)	m³/h	1,180/980/720	1,400/1,120/900	1,600/1,300/1,000	1,850/1,700/1,550	2,100/1,700/1,400
	Sound Level (SPL)(Hi/Med/Lo)	dB(A)	45/42/37	48/46/42	50/45/42	51/49/47	51/45/42
	Sound Level (PWL)(Hi)	dB(A)	59	62	65	64	65
	Controller (Type/Model)		Wireless/H CRA31NEWH	Wireless/H CRA31NEWH	Wireless/H CRA31NEWH	Wireless/H CRA31NEWH	Wireless/H CRA31NEWH
	Drain pump		Standard	Standard	Standard	Standard	Standard
	Air filter		Standard	Standard	Standard	Standard	Standard
Panel	Dimension (W×H×D)	mm	950×37×950	950×37×950	950×37×950	950×37×950	950×37×950
	Weight (Net/Gross)	kg	6.0/10.0	6.0/10.0	6.0/10.0	6.0/10.0	6.0/10.0
Compressor	Type		ROTARY	ROTARY	ROTARY	ROTARY	ROTARY
Outdoor unit	Dimension (W×H×D)	mm	860×670×310	860×670×310	950×840×340	950×1,050×340	950×1,386×340
	Weight (Net/Gross)	kg	49/53	49/53	70/75	85/95	101.5/114.5
	Air Volume (Hi)	m³/h	3,150	3,150	3,800	5,800	6,300
	Sound Level (SPL)(Hi)	dB(A)	54	54	58	62	67
	Sound Level (PWL)(Hi)	dB(A)	69	70	70	76	80
	Refrigerant (Type/Amount)	kg	R32/1.40	R32/1.45	R32/2.00	R32/2.50	R32/3.00
Refrigerant piping	Liquid/Gas	mm(inch)	Φ9.52/Φ15.88 (3/8'/5/8')	Φ9.52/Φ15.88 (3/8'/5/8')	Φ9.52/Φ19.05 (3/8'/3/4')	Φ9.52/Φ19.05 (3/8'/3/4')	Φ9.52/Φ19.05 (3/8'/3/4')
	Max.pipe length	m	30	50	50	50	50
	Max.height difference (OD lower)	m	15	30	30	30	30
	Max.height difference (OD higher)	m	15	30	30	30	30
	Add Refrigerant Amount	g/m	28	28	28	28	28
	Pipe Length for Additional Refrigerant	m	5	5	5	5	5
Ambient temperature	Cooling	°C	-15~+48	-15~+48	-15~+48	-15~+48	-15~+48
	Heating	°C	-15~+24	-15~+24	-15~+24	-15~+24	-15~+24

Nominal testing conditions:
Cooling - Indoor 80.6°F DB / 66.2°F WB (27°C DB / 19°C WB) & Outdoor 95°F DB / 75.2°F WB (35°C DB / 24°C WB)
Heating - Indoor 68°F DB / 59°F WB (20°C DB / 15°C WB) & Outdoor 44.6°F DB / 42.8°F WB (7°C DB / 6°C WB)

SPECIFICATIONS

DUCTED

IDU		RPIH-3.0UFE1NH	RPIH-3.5UFE1NH	RPIH-4.0UFE1NH	RPIH-5.0UFE1NH	RPIH-6.0UFE1NH	RPIH-6.5UFE1NH	
ODU		RAS-3.0UFESNH1	RAS-3.5UFESNH1	RAS-4.0UFESNH1	RAS-5.0UFESMH1	RAS-6.0UFESMH1	RAS-6.5UFESMH1	
Power supply (Indoor)	V/Ph/Hz	220~240/1/50	220~240/1/50	220~240/1/50	220~240/1/50	220~240/1/50	220~240/1/50	
Power supply (Outdoor)	V/Ph/Hz	220~240/1/50	220~240/1/50	220~240/1/50	380~415/3/50	380~415/3/50	380~415/3/50	
Max.input consumption	W	4,100	4,100	5,100	6,400	7,200	7,800	
Max.input current	A	18.1	18.0	22.5	11.6	12.6	13.1	
Average (Cooling)	Pdesignc	kW	6.90	8.50	10.10	12.10	14.19	
	SEER	W/W	6.29	6.20	6.10	6.28	5.94	
	ηs,c	100%	-	-	-	248%	235%	
	Energy Efficiency Class		A++	A++	A++	-	-	
	Annual energy consumption	kWh/a	395	499	577	761	849	
Average (Heating)	Pdesignh	kW	6.00	6.50	8.20	9.50	12.40	
	SCOP	W/W	4.05	4.00	3.92	3.70	3.72	
	ηs,c	100%	-	-	-	145%	145%	
	Energy Efficiency Class		A+	A+	A	-	-	
	Annual energy consumption	kWh/a	2,007	2,313	2,926	3,674	4,694	
Cooling	Capacity (Rated)	kW	6.90	8.50	10.10	12.10	14.19	
	Capacity (Range.Min~Max)	kW	2.45~7.85	4.00~9.50	3.50~11.00	3.30~13.20	3.20~16.00	
	Input	kW	2.16	2.67	3.80	4.22	4.78	
	Current	A	9.5	11.6	17.1	7.4	8.7	
	EER	W/W	3.19	3.18	2.66	2.87	2.97	
	Heating	Capacity (Rated)	kW	8.30	9.00	10.50	13.40	16.13
Capacity (Range.Min~Max)		kW	2.20~8.70	3.50~9.40	3.32~12.00	3.00~14.60	3.40~18.50	
Input		kW	2.22	2.40	3.50	4.07	4.65	
Current		A	10.3	10.5	16.0	7.3	8.4	
COP		W/W	3.74	3.75	3.00	3.29	3.47	
Indoor unit		Dimension (W×H×D)	mm	1,180×190×445	1,140×268×720	1,140×268×720	1,300×350×800	1,300×350×800
	Weight (Net/Gross)	kg	24/27.5	37.5/44.5	37.5/44.5	51/60	51/60	
	Air Volume (Hi/Med/Lo)	m ³ /h	1,000/700/490	1,450/1,120/900	1,800/1,600/1,400	1,750/1,500/1,300	2,400/2,200/1,900	
	Sound Level (SPL)(Hi/Med/Lo)	dB(A)	38/34/31	41/38/33	42/40/38	43/40/37	47/45/42	
	Sound Level (PWL)(Hi)	dB(A)	61	63	65	69	77	
	External Static Pressure (Rated)	Pa	25	37	37	50	50	
	External Static Pressure (Range)	Pa	0~40	0~120	0~120	0~120	0~120	
	Controller (Type/Model)		Wired/HCWA21NEWH	Wired/HCWA21NEWH	Wired/HCWA21NEWH	Wired/HCWA21NEWH	Wired/HCWA21NEWH	
	Drain pump		Standard	Standard	Standard	Standard	Standard	
	Air filter		Standard	Standard	Standard	Standard	Standard	
	Compressor	Type		ROTARY	ROTARY	ROTARY	ROTARY	ROTARY
		Dimension (W×H×D)	mm	860×670×310	860×670×310	950×840×340	950×1,050×340	950×1,386×340
	Outdoor unit	Weight (Net/Gross)	kg	49/53	49/53	70/75	85/95	101.5/114.5
Air Volume (Hi)		m ³ /h	3,150	3,150	3,800	5,800	6,300	
Sound Level (SPL)(Hi)		dB(A)	54	54	58	62	62	
Sound Level (PWL)(Hi)		dB(A)	69	70	70	76	76	
Refrigerant (Type/Amount)		kg	R32/1.40	R32/1.45	R32/2.00	R32/2.50	R32/3.00	
Refrigerant piping		Liquid/Gas	mm(inch)	Φ9.52/Φ15.88 (3/8"/5/8')	Φ9.52/Φ15.88 (3/8"/5/8')	Φ9.52/Φ19.05 (3/8"/3/4')	Φ9.52/Φ19.05 (3/8"/3/4')	
Refrigerant piping	Max.pipe length	m	30	50	50	50	50	
	Max.height difference (OD lower)	m	15	30	30	30	30	
	Max.height difference (OD higher)	m	15	30	30	30	30	
	Add Refrigerant Amount	g/m	28	28	28	28	28	
	Pipe Length for Additional Refrigerant	m	5	5	5	5	5	
	Ambient temperature	Cooling	°C	-15~+48	-15~+48	-15~+48	-15~+48	-15~+48
Heating		°C	-15~+24	-15~+24	-15~+24	-15~+24	-15~+24	

Nominal testing conditions:
 Cooling - Indoor 80.6°F DB / 66.2°F WB (27°C DB / 19°C WB) & Outdoor 95°F DB / 75.2°F WB (35°C DB / 24°C WB)
 Heating - Indoor 68°F DB / 59°F WB (20°C DB / 15°C WB) & Outdoor 44.6°F DB / 42.8°F WB (7°C DB / 6°C WB)

SPECIFICATIONS

FLOOR CEILING CONVERTIBLE

IDU		RPFC-3.0UFE1NH	RPFC-3.5UFE1NH	RPFC-4.0UFE1NH	RPFC-5.0UFE1NH	RPFC-6.0UFE1NH	RPFC-6.5UFE1NH
ODU		RAS-3.0UFESNH1	RAS-3.5UFESNH1	RAS-4.0UFESNH1	RAS-5.0UFESMH1	RAS-6.0UFESMH1	RAS-6.5UFESMH1
Power supply (Indoor)	V/Ph/Hz	220-240/1/50	220-240/1/50	220-240/1/50	220-240/1/50	220-240/1/50	220-240/1/50
Power supply (Outdoor)	V/Ph/Hz	220-240/1/50	220-240/1/50	220-240/1/50	380-415/3/50	380-415/3/50	380-415/3/50
Max.input consumption	W	4,100	4,100	5,100	6,400	7,200	7,800
Max.input current	A	18.1	18.0	22.5	11.6	12.6	13.1
Average (Cooling)	Pdesignc	kW	6.50	8.60	9.80	12.10	16.30
	SEER	W/W	5.81	6.10	5.87	5.70	5.33
	ηs,c	100%	-	-	-	225%	210%
	Energy Efficiency Class		A+	A++	A+	-	-
	Annual energy consumption	kWh/a	391	509	585	803	940
Average (Heating)	Pdesignh	kW	6.00	6.50	7.90	9.50	12.20
	SCOP	W/W	4.01	4.10	3.82	3.78	3.55
	ηs,c	100%	-	-	-	148%	139%
	Energy Efficiency Class		A+	A+	A	-	-
	Annual energy consumption	kWh/a	2,168	2,192	2,825	3,868	5,015
Cooling	Capacity (Rated)	kW	6.50	8.60	9.80	12.10	13.76
	Capacity (Range.Min-Max)	kW	2.45-7.85	3.50-9.00	3.50-11.00	3.30-13.20	3.10-16.10
	Input	kW	1.94	2.95	3.75	4.40	5.00
	Current	A	9.1	12.7	16.9	7.5	8.5
	EER	W/W	3.35	2.92	2.61	2.75	2.75
Heating	Capacity (Rated)	kW	7.35	8.70	10.50	13.50	16.59
	Capacity (Range.Min-Max)	kW	2.20-8.70	3.00-9.20	3.32-12.00	3.00-14.60	3.60-18.00
	Input	kW	2.07	2.30	3.65	4.17	4.85
	Current	A	9.70	10.00	16.50	7.30	9.00
	COP	W/W	3.55	3.78	2.88	3.24	3.42
Indoor unit	Dimension (W×H×D)	mm	990×230×680	1,285×230×680	1,285×230×680	1,580×230×680	1,580×230×680
	Weight (Net/Gross)	kg	30/35	37/44	37/44	48/56	48/56
	Air Volume (Hi/Med/Lo)	m ³ /h	1,100/950/800	1,450/1,120/900	1,700/1,500/1,300	2,000/1,800/1,600	2,000/1,600/1,200
	Sound Level (SPL)(Hi/Med/Lo)	dB(A)	51/48/44	54/48/43	54/52/51	54/51/48	58/52/46
	Sound Level (PWL)(Hi)	dB(A)	65	65	65	68	75
	Controller (Type/Model)		Wireless/H CRA31NEWH	Wireless/H CRA31NEWH	Wireless/H CRA31NEWH	Wireless/H CRA31NEWH	Wireless/H CRA31NEWH
	Drain pump		Optional	Optional	Optional	Optional	Optional
	Air filter		Standard	Standard	Standard	Standard	Standard
Compressor	Type	ROTARY	ROTARY	ROTARY	ROTARY	ROTARY	
Outdoor unit	Dimension (W×H×D)	mm	860×670×310	860×670×310	950×840×340	950×1,050×340	950×1,386×340
	Weight (Net/Gross)	kg	49/53	49/53	70/75	85/95	101.5/114.5
	Air Volume (Hi)	m ³ /h	3,150	3,150	3,800	5,800	6,300
	Sound Level (SPL)(Hi)	dB(A)	54	54	58	62	67
	Sound Level (PWL)(Hi)	dB(A)	69	70	70	76	80
	Refrigerant (Type/Amount)	kg	R32/1.40	R32/1.45	R32/2.00	R32/2.50	R32/3.00
Refrigerant piping	Liquid/Gas	mm(inch)	Φ9.52/Φ15.88 (3/8"/5/8")	Φ9.52/Φ15.88 (3/8"/5/8")	Φ9.52/Φ19.05 (3/8"/3/4")	Φ9.52/Φ19.05 (3/8"/3/4")	Φ9.52/Φ19.05 (3/8"/3/4")
	Max.pipe length	m	30	50	50	50	50
	Max.height difference (OD lower)	m	15	30	30	30	30
	Max.height difference (OD higher)	m	15	30	30	30	30
	Add Refrigerant Amount	g/m	28	28	28	28	28
	Pipe Length for Additional Refrigerant	m	5	5	5	5	5
Ambient temperature	Cooling	°C	-15--+48	-15--+48	-15--+48	-15--+48	-15--+48
	Heating	°C	-15--+24	-15--+24	-15--+24	-15--+24	-15--+24

Nominal testing conditions:
Cooling - Indoor 80.6°F DB / 66.2°F WB (27°C DB / 19°C WB) & Outdoor 95°F DB / 75.2°F WB (35°C DB / 24°C WB)
Heating - Indoor 68°F DB / 59°F WB (20°C DB / 15°C WB) & Outdoor 44.6°F DB / 42.8°F WB (7°C DB / 6°C WB)