

SET FREE mini

VARIABLE REFRIGERANT FLOW
AIR SOURCE HEAT PUMP TYPE
HNRQ series

Free

Company Name

CUSTOMER SERVICE

SALES OFFICE

SPARE PARTS

DISTRIBUTOR

CERTIFICATION

WARRANTY

SOCIAL MEDIA

The specifications of this catalog may change without prior notice to allow Hitachi Cooling & Heating to incorporate the latest innovations for its customers.

The information contained in this catalog is merely informative. Hitachi Cooling & Heating declines any responsibility in the broadest sense, for damage, direct or indirect, arising from the use and / or interpretation of the recommendations in this catalog.

Find the products of Hitachi Cooling & Heating with the best service and conditions at your Hitachi Distributor

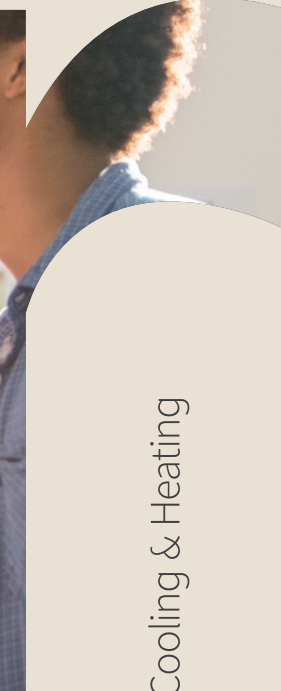

Cooling & Heating

Welcome

Air. It's a wonderful thing.

Invisible, silent and life-giving, air makes our entire world possible. It surrounds us, continuously energizing, cooling and warming. It can be unpredictable and sometimes challenging, but when air is in harmony with us, everything seems that much easier.

This is our vision. To create the air that makes life better.



Living Harmony

At Hitachi Cooling & Heating we like to think of this as creating harmony with your interior environment. When we achieve that wonderful balance, productivity, learning, happiness and health can thrive.

We call this 'Living Harmony' and it's at the center of everything we do.

The future together

Living Harmony puts people first. By balancing the human needs of our customers with an uncompromising approach to innovation and quality, we can continue to create the technologies for a more comfortable and balanced world.

Your world. We live in it together.

The beauty of balance

No matter what the weather is like outside, when you're indoors, you want to have complete control over your environment. At work or play, awake or asleep, you're free to create your own atmosphere; balancing energy with calm, sound with silence and light with shade. It's the same for cooling and heating.

When the air around you is in balance, you can enjoy life indoors that much more.

Your world and Hitachi

Live within a climate of your own making

Air ... To us it is something that is taken too much for granted. So much so, that we can even forget it exists. Nevertheless, air is so essential that we could not go on living without it. We believe that the ability to control the air indoors to our own liking, no matter what the environment outdoors, is a truly wonderful thing.

We want to create pleasant spaces of Living Harmony everywhere, for people all over the world.

With this thought in mind, we shall continue to produce technology that assures people can lead lives of comfort, safety and security.

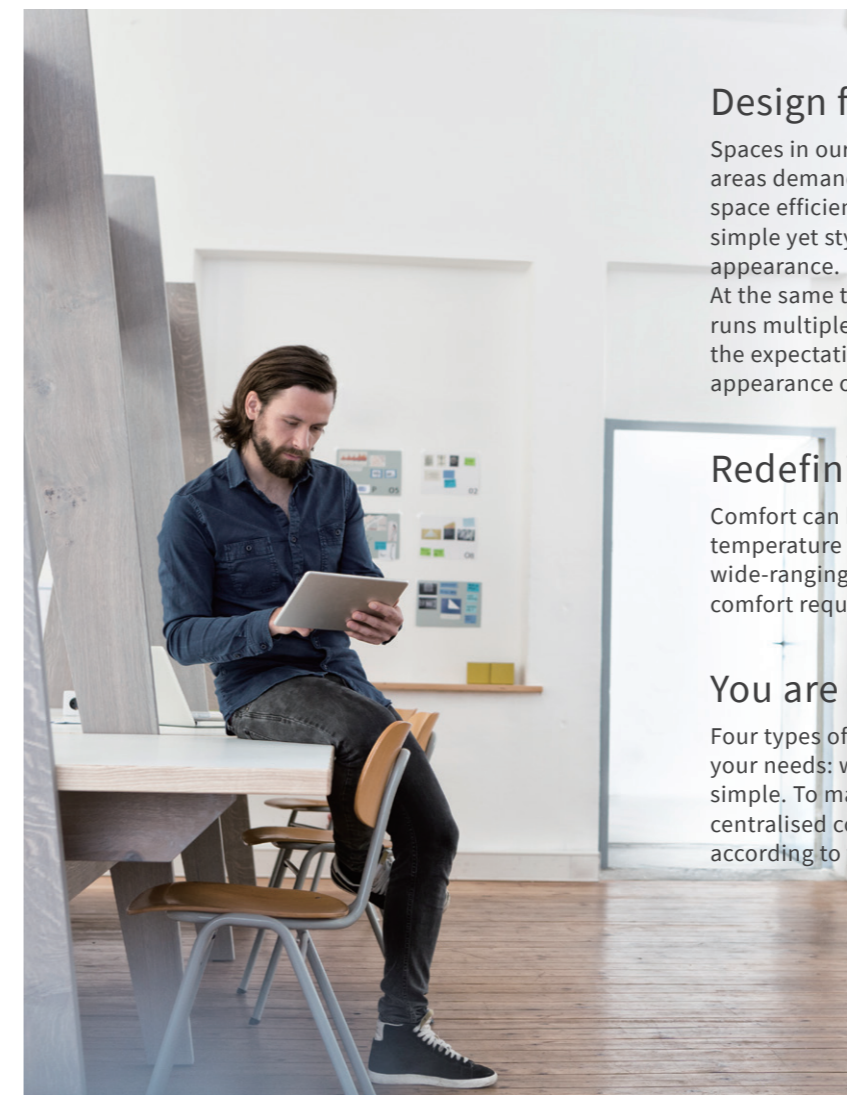
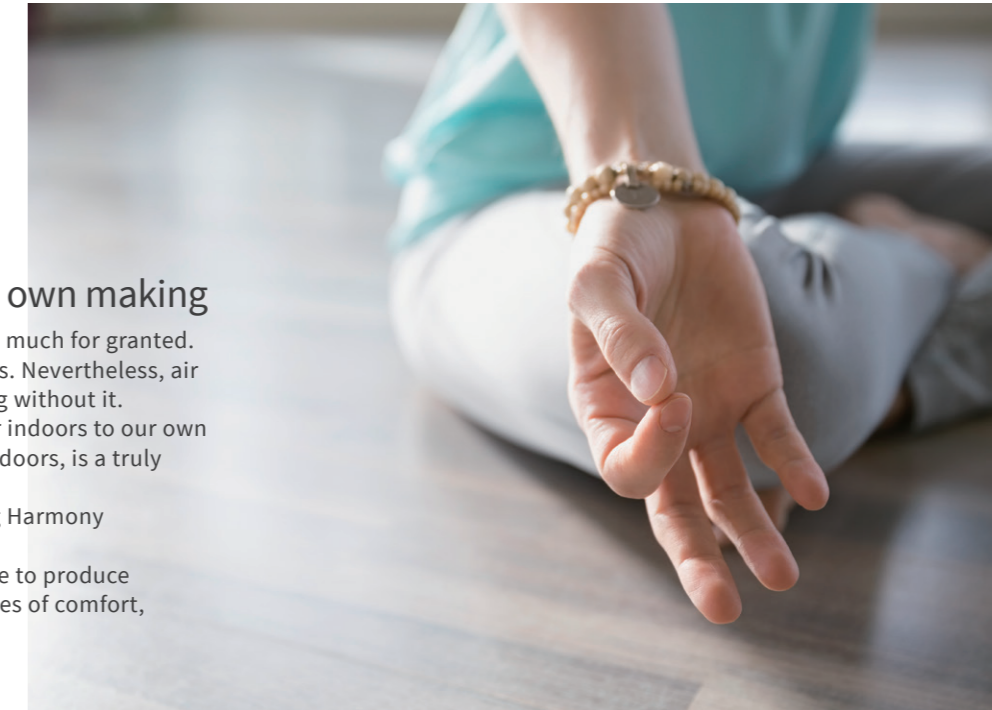

Design for tomorrow's urban spaces

Spaces in our cities are under increasing pressure. Urban areas demand landscape preservation, and also require space efficiency. SET FREE mini outdoor units have a simple yet stylish design that does not mar the urban appearance.

At the same time, since a powerful and compact unit runs multiple indoor units, it meets urban needs and the expectations of users who are concerned about the appearance of their surroundings.

Redefining comfort

Comfort can be felt in a variety of ways, from the temperature to quietness and even the air flow itself. Our wide-ranging line-up of indoor units can match various comfort requirements.

You are in control

Four types of individual controllers are available to match your needs: wireless and wired, and from advanced to simple. To manage energy and maintenance costs, our centralised controllers range from small to large. Select according to your needs, to enable your control.



Introducing SET FREE mini

Helping You Form An Ideal Living Environment

We want to create a comfortable living environment where people can enjoy life to the full. SET FREE mini embodies such a wish. A host of outdoor units, indoor units and control devices matches the needs of various living spaces. Which is not only gratifying for the owners who use them, but also brings diverse benefits to architects, installers and other customers involved in space design.

AESTHETICS



We can offer you a number of options that help enhance the aesthetics of your building.

- High external pressure of outdoor unit up to 30Pa (7-8HP Class)
- Fashionable outdoor and indoor unit appearance
- Large capacity outdoor unit saves installation space

HIGHER PERFORMANCE



We are committed to offering better energy-saving results with our improved outdoor units, indoor units and advanced control systems.

- DRED - Demand Response Enabling Device Availability
- Higher performance in both EER and COP
- Low standby power consumption design

ADAPTABILITY



Both the quality and capability of adjustment to your environment are benefits of the HNRQ Series.

- Up to 52.0°C ambient temperature for cooling operations
- Noise reduction mode
- As low as -23.0°C (7-12HP) ambient temperature for heating operations

EASY SERVICING AND MAINTENANCE



Our original transmission system, H-LINK, and newly improved PCB support smooth servicing and maintenance.

- H-LINK
- User-friendly service board for easier testing and diagnostics

DESIGN FLEXIBILITY



Any local requirements and constraints can be met with a number of improvements in the outdoor unit.

- Flexibility up to 180m total liquid piping
- Wide range of indoor units availability (Up to 19units)
- High external pressure of outdoor unit
- Small body with large capacity

COMFORT



Our units offer you a degree of comfort, even in winter or in high humidity environments.

- 0.5°C setpoint
- Smart defrosting

EASY INSTALLATION



Overall cost and time reduction can be achieved thanks to our newly designed outdoor units and original H-LINK system.

- Slim and lightweight body
- H-LINK
- Four directions of piping in outdoor unit
- Diagnostics using the outdoor unit's 7-segment displays

WARRANTY



- 5 years Warranty for both Residential use and Commercial use

10 reasons to choose Hitachi VRF



World's trusted brand

Engineered with precision in Japan, Hitachi has been one of the best-selling VRF brands around the world since our first launch in 1983.



HVAC professionals: We care about you

Each of our VRF equipment is carefully designed for ease of installation and maintenance. Piping routes, access to components, condensate management ... our products make your job easy!



Advanced features, more comfort for the occupants

From exclusive GentleCool temperature control function to 4-way cassette with individual louver control, our VRF systems embeds various features to enhance the well being of occupants, based on their needs.



Welcome to our "Central Stations"

Hitachi best-in-class & appraised range of centralized controllers make VRF system control easy. Our various Central Stations models can suit all types of user profiles and system sizes, so that every operator can control and adjust operations as they wish.



SmoothDrive™: patented technology for unique benefits

Our exclusive VRF compressor control technology SmoothDrive™ provide unrivaled efficiency and comfort. Our systems meet the most stringent energy efficiency regulatory standards. But they do more than that. Thanks to SmoothDrive™, you can save more energy during partial load conditions, reflecting the real life usage of VRF systems. When some indoor units are turned off, when the outdoor temperature changes, when the indoor temperature reaches comfortable level ... SmoothDrive™ provides extra savings and comfort, which made Hitachi VRF receive energy-efficiency awards in Japan.



airCloud Pro, new generation of monitoring (exclusive!)

From your smartphone or web, manage your VRF systems in full simplicity. Operators can select zones and adjust AC operation, or track systems errors remotely. airCloud Pro can accommodate unlimited number of VRF systems and unlimited number of users.



airCloud Select NEW

Let's jump in our "Selection Software", where system engineers can perform their work of air conditioning selection customized for each project. With our training material & selection software, professionals can meet their clients' requirements with confidence.



Whichever is your project

From small shops to sky scrapper, from snowy days to hottest climates, there's a Hitachi VRF solution for you. Our offer provides great flexibility: multiple types of outdoor units and indoor units, piping distance, adaptive external static pressure, best-in-class choice of CH-Box, and variety of controllers for each type of users.



Support building owners with multiple tenants

Our exclusive Central Station EX enables owners to easily manage each tenant's air conditioning electricity consumption and invoicing. Several calculation methods are available for better accuracy.



Demand-response energy management

Smart cities, smart buildings... and smart Hitachi VRF systems! Discover our two advanced power saving functions: peak-load cut to prevent peak demand, and capacity moderation to reduce the power input demand. In addition, the large majority of our controls provide simplified scheduling capability, so that operations can schedule operations according to their utility plan.

Complete VRF offer Select and combine as you need!

Versatile Outdoor units

- Top flow modular
- Side flow "mini"
- SideSmart modular(exclusive)
- Centrifugal(exclusive)
- Water-source
- 3 types: Cooling only, Heat pump(2-pipes), Heat recovery(3-pipes)

Variety of indoor units

- Over 30 models available around the globe
- Wide range of ceiling cassettes and ducted units for all types of configuration
- Ventilation
- Air Handling Unit Integration to Hitachi VRF

User-friendly controls

- Central Stations: large choice of interfaces for simple centralized control operations
- Individual controllers: variety of types
- airCloud Pro: cloud-based monitoring available in smartphone app and web

*Product availability varies across countries. Please visit www.hitachiaircon.com or contact your local Hitachi Cooling & Heating representative to receive more information.

VRF OUTDOOR UNITS

- 09 LINE UP OVERVIEW
- 10 BETTER PERFORMANCE
- 11 DESIGN FLEXIBILITY
- 13 ADAPTABILITY
- 14 EASY INSTALLATION
- 15 SPECIFICATIONS



wing to three types of outdoor unit with enhanced design and performance, we intelligently meet the requirements of various buildings as regards scale and construction, as well as air-conditioning needs. We believe that the paths to comfortable living all begin with Hitachi outdoor units.

LINE UP OVERVIEW

OFFERING YOU OUTDOOR UNITS



	Cooling Capacity	Heating Capacity	Weight
7HP Class	20.0kW	22.4kW	153kg
8HP Class	22.4kW	25.0kW	153kg
9HP Class	25.0kW	26.0kW	153kg
10HP Class	28.0kW	31.5kW	160kg
11HP Class	31.0kW	33.9kW	170kg
12HP Class	33.5kW	37.5kW	170kg

SUMMARY TABLE

Item	Unit	HNRQ Series
Capacity	HP class	HP 7-12
	Nominal cooling	kW 20.0-33.5
	Nominal heating	kW 22.4-37.5
Connectable indoor unit quantity	unit	1-10
Combination capacity ratio between ODU and IDU (all range)	%	50-130
Maximum piping length	Total liquid piping length	m 180
	Between outdoor unit and farthest indoor unit	m 100
	Between 1st branch multi kit and farthest indoor unit	m 40
	Between multi kit and each indoor unit	m 15
Maximum level difference	Between outdoor unit and indoor units (ODU above IDU)	m 50
	Between outdoor unit and indoor units (IDU above ODU)	m 40
	Between indoor units	m 15
Cooling operation range *1	°C DB	From -5.0 to 52.0°C
Heating operation range *2	°C DB	From -23.0 to 15.5°C

*1 Interval operation (for 7-12HP) from 43.0 to 52.0°C
 *2 Interval operation (for 7-12HP) from -23.0 to -15.0°C

BETTER PERFORMANCE

HIGHER PERFORMANCE IN BOTH EER AND COP

The HNRQ Series offers greater energy efficiency and a higher coefficient of performance, contributing to the environment while being easier on the wallet.

EER: Energy Efficiency Ratio
Cooling EER

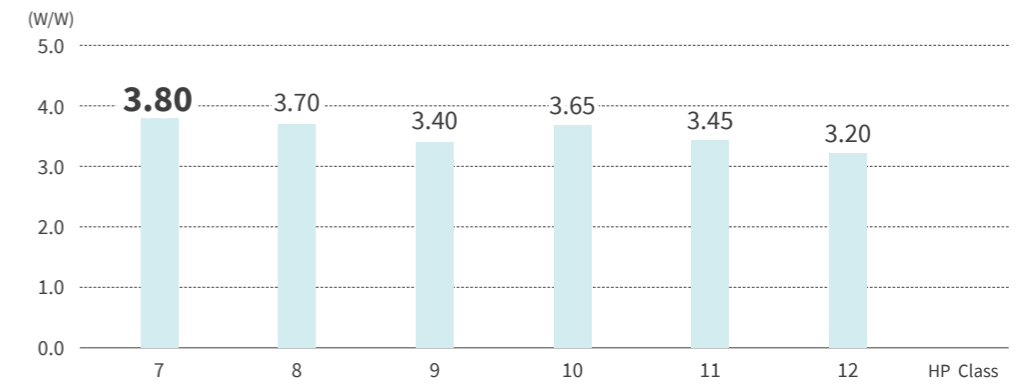

COP: Coefficient Of Performance
Heating COP

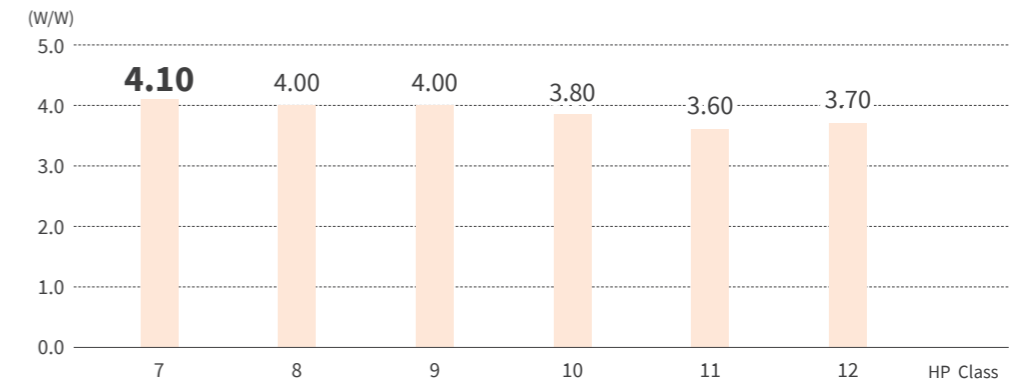

EASIER ENERGY MANAGEMENT OFFERING AT HAND

With your Advanced Color Wired Remote Controller (PC-ARFG1) at hand, You can have two options of energy-saving control for outdoor unit operation, Depending on how much you want to decrease your energy consumption.

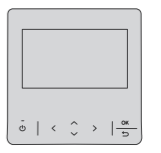

PC-ARFG1

Outdoor unit capacity control ⇔ two options

(1) Peak-cut control: set the limit on the power consumption range

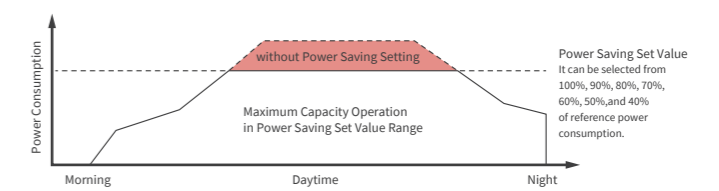
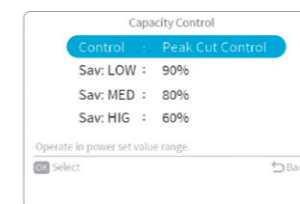

(2) Moderate control: keep the power consumption within proper limit (40-90%)

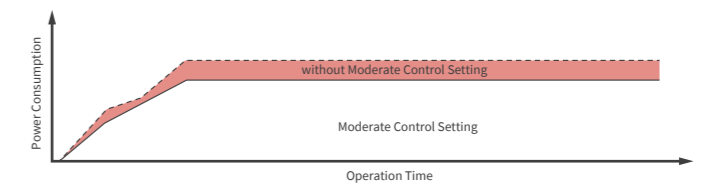
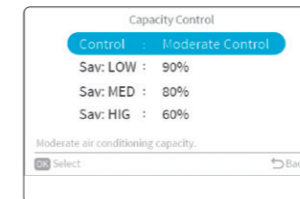

DESIGN FLEXIBILITY

PIPING FLEXIBILITY

Longer and more flexible piping has been realized. This helps in dealing with various piping restrictions.

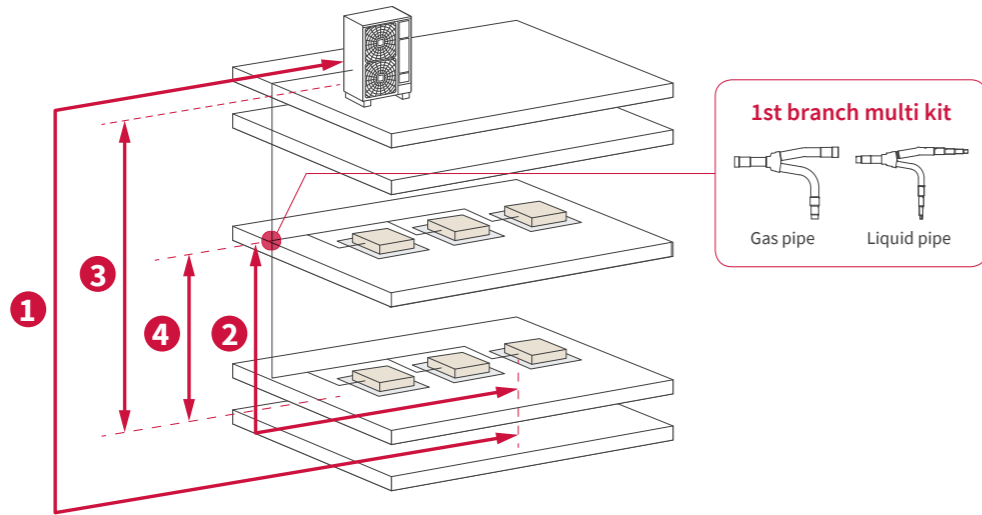

Maximum piping length

	7-12HP Class
Total piping length	180m
1 Between outdoor unit and farthest indoor unit	100m
2 Between 1st branch multi kit and farthest indoor unit	40m

Each maximum length or level difference has several conditions, please refer to the technical documents in inquiry.

Maximum level difference

	7-12HP Class
3 Between outdoor unit and indoor units	ODU above IDU 50m IDU above ODU 40m
4 Between indoor units	15m

POWERFULNESS IN AIR

High external pressure of outdoor unit

High external static pressure up to 30Pa is available in order to avoid air short-circuit conditions. This ensures that the outdoor unit runs with a good ventilating condition under different conditions of installation.

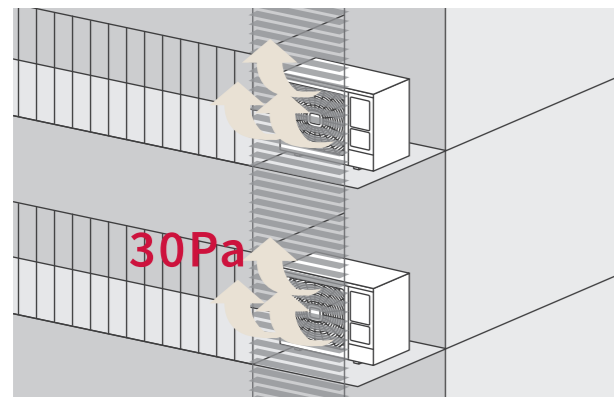

※ 30Pa is only available for between 3-8HP class

Our SET FREE mini outdoor units are designed to be located internally by the straightness of air flow thanks to higher external static pressure with DC inverter fan, leading to more options for installation and visual aesthetics of buildings.

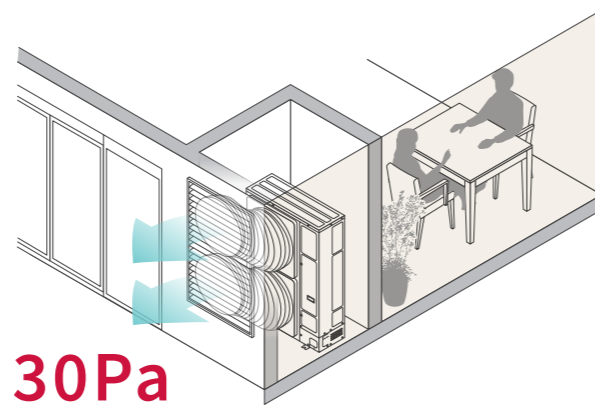

SMALL BODY WITH LARGE CAPACITY

Since the HNRQ Series adopts a more compact outdoor unit compared with the top-blowing type large capacity outdoor unit, it offers an increased degree of freedom of installation.

Height-limited space

Top Flow type

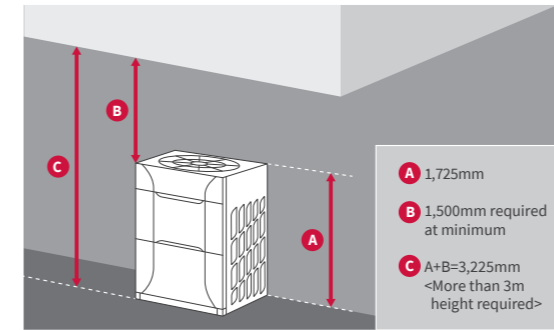

HNRQ Series

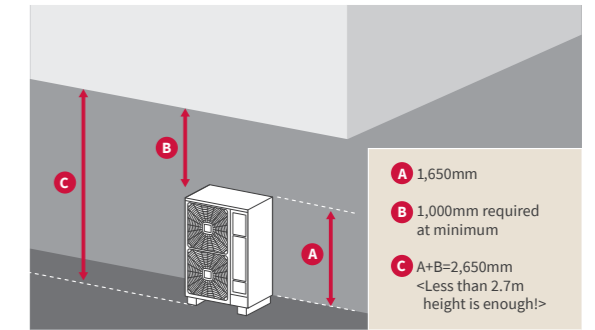

Better limit in Height!

Depth-limited space

Top Flow type

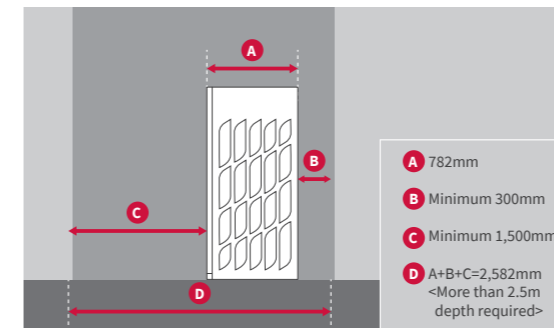

HNRQ Series

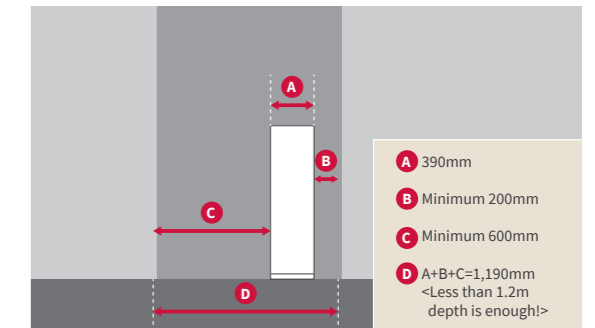

Better limit in Depth!

* 8HP Class
* Please refer to the installation manual for more details.

WIDE INDOOR UNIT COMBINATION

Because of the large-capacity outdoor unit, it is possible to install a whole range of indoor units in various rooms using one outdoor unit.

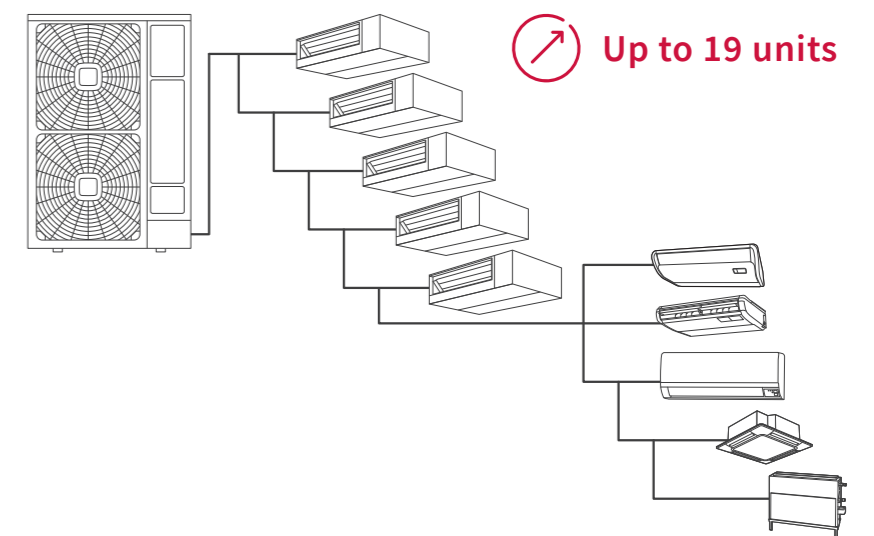

ADAPTABILITY

THE BEAUTY OF SILENCE

Balance is the key to harmony, so SET FREE mini outdoor units incorporates advanced features to ensure a more peaceful environment with less disturbance to the outside environment

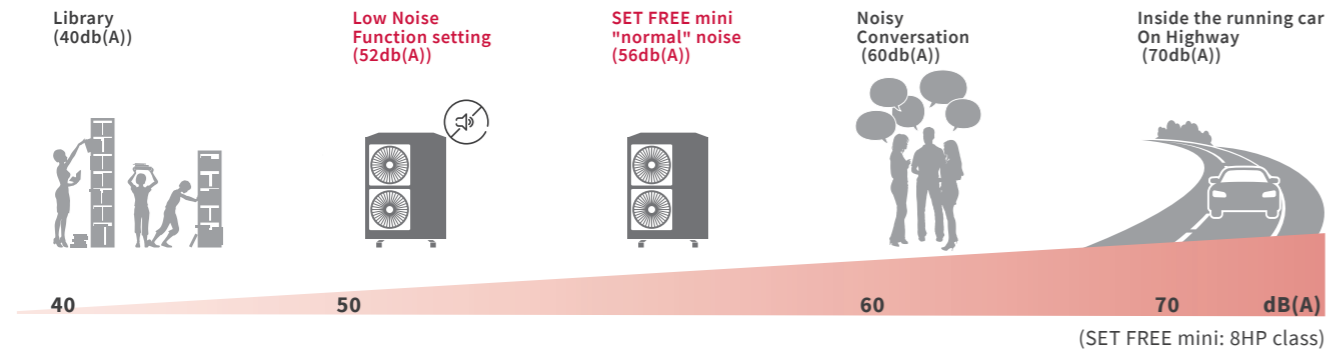
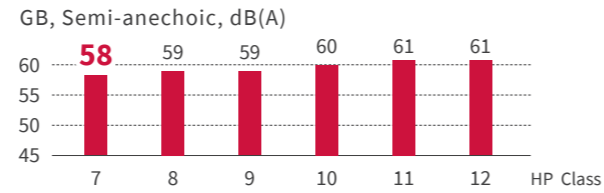

UP TO 52.0°C AMBIENT TEMPERATURE FOR COOLING OPERATIONS

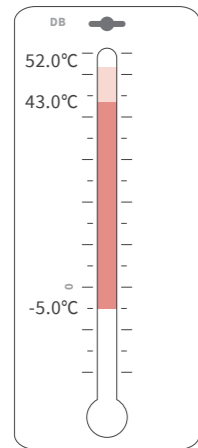

7-12HP

Stable Interval

- Up to 43.0°C stable running
 - Up to 52.0°C interval running
- Special fresh air intake and trapezoid heat sink design are adopted for the inverter driver. This improves heat emission and allows the system to be running stably under high ambient conditions.

* When the model of RAS-7.0-12HNBRMQ2 outdoor unit is connected to the compact ducted type indoor units (RPIZ), if only one indoor unit is in cooling operation, and the capacity is less than 2.8kW, the minimum outdoor temperature is 5.0°C DB.

AS LOW AS -23.0°C AMBIENT TEMPERATURE FOR HEATING OPERATIONS

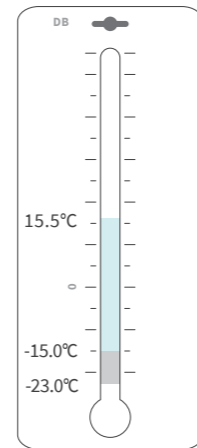

7-12HP

Stable Interval

- As low as -15.0°C stable running
 - As low as -23.0°C (7-12HP) interval running
- Special 3-row coil design (10/11/12HP class) and larger area of coil enhance heating capability. This enables heating as low as -20.0°C ambient condition even in cold regions.

EASY INSTALLATION

FOUR DIRECTIONS OF PIPING IN OUTDOOR UNIT

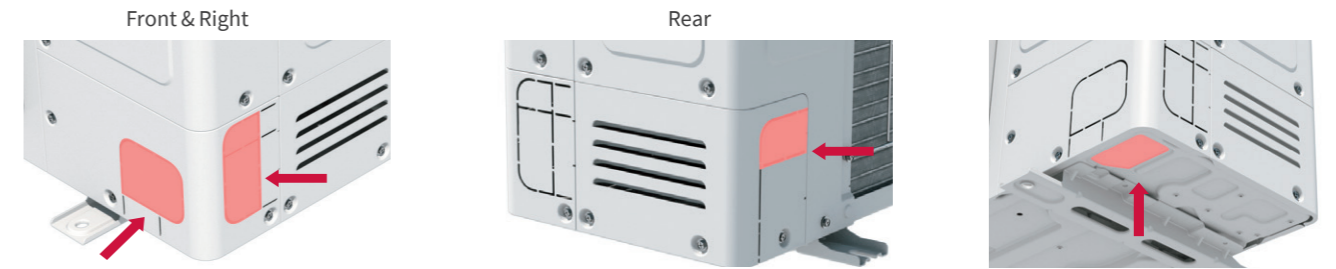

Stop valve built with 4-directional outlet piping for easier pipe installation. The refrigerant pipes can connect the stop valves from the front and right, rear and bottom of the unit.

USER-FRIENDLY SERVICE BOARD FOR EASIER TESTING AND DIAGNOSTICS

User-friendly service board with dial code switch and push button is designed for easier testing and diagnostics. The service board, which is located in front of the outdoor unit, is easy to set.

Functions are as follows:

- Monitoring real-time running status
- Displaying the fault code for diagnostics
- Checking historical fault information
- Optimizing control parameters based on the installation field condition

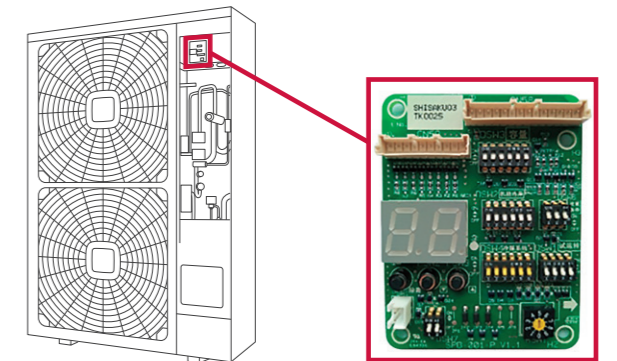

H-LINK

H-LINK requires only two transmission wires connected to each outdoor unit for up to 64 refrigerant cycles, and connecting wires for all indoor units and outdoor units.

- Flexible installation options
- No polarity requirements
- Centralised Controller is enabled via indoor or outdoor unit
- Up to 160 indoor units and outdoor units can be connected
- Possible to have a cable length of up to 1,000m

Centralised Controller to Outdoor Unit

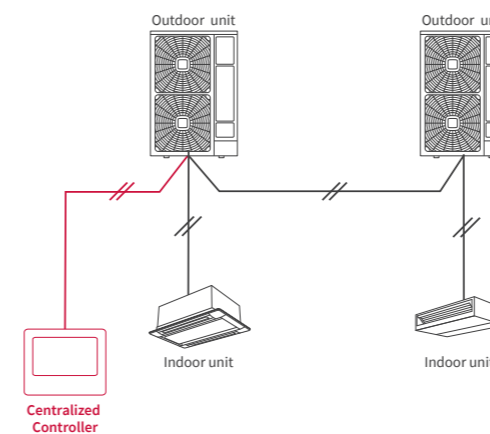

Centralised Controller to Indoor Unit

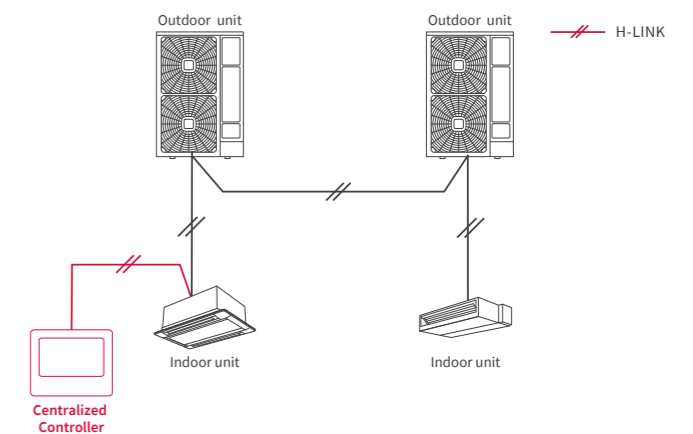

>>>>More details see to P000

SPECIFICATIONS



HP Class			7	8	9	10	11	12
Model			RAS-070HNBRMQ2	RAS-080HNBRMQ2	RAS-090HNBRMQ2	RAS-100HNBRMQ2	RAS-110HNBRMQ2	RAS-120HNBRMQ2
Power Supply	V/Ph/Hz		380-415/3/50	380-415/3/50	380-415/3/50	380-415/3/50	380-415/3/50	380-415/3/50
Capacity	Cooling	kW	20.0	22.4	25.0	28.0	31.0	33.5
	Heating	kW	22.4	25.0	26.0	31.5	33.9	37.5
Power Input	Cooling	kW	5.26	6.05	7.35	7.67	8.99	10.47
	Heating	kW	5.46	6.25	6.50	8.29	9.42	10.14
Air Flow Rate	Standard	m ³ /min	121	121	121	160	163	163
Dimensions	H×W×D	mm	1,650×1,100×390	1,650×1,100×390	1,650×1,100×390	1,650×1,100×390	1,650×1,100×390	1,650×1,100×390
Weight	Net	kg	153	153	153	160	170	170
Footprint Area		m ²	0.43	0.43	0.43	0.43	0.43	0.43
Packaging Volume		m ³	1.13	1.13	1.13	1.13	1.13	1.13
Compressor Type			Scroll	Scroll	Scroll	Scroll	Scroll	Scroll
Refrigerant	Type		R410A	R410A	R410A	R410A	R410A	R410A
	Charge Amount	kg	5.6	5.6	5.6	7.0	9.0	9.0
Refrigerant Oil	Model		FV68H	FV68H	FV68H	FVC68D	FVC68D	FVC68D
	Charge Amount	L	1.60	1.60	1.60	1.90	1.90	1.90
Number of Fan Motors			2	2	2	2	2	2
Capacity Ratio of IDU/ODU	%		50-130%	50-130%	50-130%	50-130%	50-130%	50-130%
Sound Pressure Level	Semi-anechoic	dB(A)	58	59	59	60	61	61
Piping	Liquid	mm	φ9.52	φ9.52	φ9.52	φ12.70	φ12.70	φ12.70
	Gas	mm	φ19.05	φ19.05	φ19.05	φ19.05*	φ19.05**	φ19.05**
Current	Max	A	20.5	20.5	20.5	26.0	26.0	26.0
	Breaker	A	25	25	25	32	32	32
Efficiency	Cooling	A	8.70	10.00	12.15	12.68	14.86	17.31
	Heating	A	9.03	10.33	10.75	13.71	15.58	16.77
Efficiency	EER	W/W	3.80	3.70	3.40	3.65	3.45	3.20
	COP	W/W	4.10	4.00	4.00	3.80	3.60	3.70
Max IDU Connect Qty.			13	13	13	16	19	19
Working Temp. Range	Cooling		From -5.0 to 52.0°C(Interval operation from 43.0 to 52.0°C)					
	Heating		From -23.0 to 15.5°C(Interval operation from -23.0 to -15.0°C)					
Refrigerant Control Mode	Electronic Expansion Valve		Microcomputer-controlled Electronic Expansion Valve					
Tubing Connection Method			Flare Connection					
Maximum Piping Length	Total Liquid Pipe Length	m	180	180	180	180	180	180
	Between ODU and farthest IDU	m	100	100	100	100	100	100
	Between 1st Branch Multi Kit and Farthest IDU	m	40	40	40	40	40	40
	Between Each Multi Kit and Each IDU	m	15	15	15	15	15	15
Maximum Level Difference	ODU above IDU	m	50	50	50	50	50	50
	IDU above ODU	m	40	40	40	40	40	40
	Between IDUs	m	15	15	15	15	15	15

* Indicates that there are pipe adapters in the outdoor unit, which are used to adjust the gas pipe between the outdoor unit and the first branch. Thus the φ19.05 diameter pipe is converted to φ22.2 diameter pipe in the model.

** Indicates that there is a pipe adapter in the model, which is used to adjust the gas pipe length between the outdoor unit and the first branch. Thus the φ19.05 diameter pipe is converted to a φ25.4 diameter pipe.

Notes:

- The EER and COP are tested under the following working conditions, when the outdoor unit is connected to the special combination of indoor units.

Working conditions for testing EER	Working conditions for testing COP
• Indoor temperature: 27.0°C DB/19.0°C WB	• Indoor temperature: 20.0°C DB
• Outdoor temperature: 35.0°C DB	• Outdoor temperature: 7.0°C DB/6.0°C WB
• Pipe length: 10.0 metre	• Pipe length: 10.0 metre
• Pipe lift: 0 metre	• Pipe lift: 0 metre
- Noise test conditions are specified below: Noise is tested 1.5 metre above ground level and 1.0 metre away from the surface of the external service board on the outdoor unit. Noise parameters are tested in a semi-anechoic chamber.
- Please consult your local distributor for indoor unit combination limitations.
- When the model of RAS-7.0-12HNBRMQ2 outdoor unit is connected to the compact ducted type indoor units (RPIZ), if only one indoor unit is in cooling operation, and the capacity is less than 2.8kW, the minimum outdoor temperature is 5.0°C DB.

OPTIONAL PARTS

Model	The model of branch pipe	
	Total liquid pipe length < 70 meters	Total liquid pipe length > 70 meters
RAS-070-090HNBRMQ2	E-102SN	E-162SN
RAS-110-120HNBRMQ2	E-162SN	



VRF INDOOR UNITS

19 SOLUTIONS TO BE MEMORIZED

- 19 WIDE RANGE OF LINE-UP
- 20 GENTLECOOL
- 20 CROWDSENSE
- 21 FEETWARM
- 23 DIRECT - INDIRECT AIRFLOW CONTROL
- 23 FLOORSENSE COOL
- 24 AUTO MOTION-SENSOR CONTROL
- 24 SETBACK MODE FOR HOTEL APPLICATION

25 IAQ: LIVE AND WORK IN HARMONY

- 25 ViroSense S filter
- 26 ViroSense Z2 filter
- 27 AQtiv-Ion Kit

29 DUCTED

- 31 HIGH ESP TYPE [RPIH-HNAUNQ] (AC MOTOR TYPE)
- MEDIUM ESP TYPE [RPIM-HNAUNQ] (AC MOTOR TYPE)
- 32 LOW ESP TYPE [RPIL-HNAUNQ] (AC MOTOR TYPE)
- COMPACT TYPE [RPIZ-HNDTSQ] (DC MOTOR TYPE)
- 33 COMPACT TYPE [RPIZ-HNATNQ] (AC MOTOR TYPE)

35 CASSETTE

- 37 Silent-Iconic™ (4-WAY CASSETTE RCI-FSRP DESIGN PANEL)
- 39 4-WAY CASSETTE TYPE [RCI-FSRP/RCI-FSKDNQ] (DC MOTOR TYPE)
- 40 4-WAY CASSETTE COMPACT TYPE [RCIM-FSRE] (DC MOTOR TYPE)
- 41 2-WAY CASSETTE TYPE [RCD-FSR] (DC MOTOR TYPE)
- 42 1-WAY CASSETTE TYPE [RCS-FSR] (DC MOTOR TYPE)

43 CONCEALED & EXPOSED

- 45 WALL MOUNTED TYPE [RPK-FSRM] (DC MOTOR TYPE)
- 46 WALL MOUNTED TYPE [RPK-HNBUSQ] (DC MOTOR TYPE)
- 47 FLOOR/CEILING CONVERTIBLE TYPE [RPFC-FSNQ] (AC MOTOR TYPE)
- 48 CEILING SUSPENDED TYPE [RPC-FSR] (DC MOTOR TYPE)
- 49 FLOOR CONCEALED TYPE [RPFI-FSNQ] (AC MOTOR TYPE)

50 GENERAL DATA & ACCESSORIES

59 VENTILATIONS

SET FREE mini offers a variety of indoor units in its line-up to achieve comfortable air conditioning that flexibly addresses various applications and shapes of space. By raising the "quality" of the air, we believe that the "quality" of time customers spend there will also be enhanced.



SOLUTIONS TO BE MEMORIZED WIDE RANGE OF LINE-UP



DUCTED

HIGH ESP TYPE (AC MOTOR TYPE)
RPIH-HNAUNQ, RPI-FSNQ



· Cooling Capacity:
8.4-16.0kW ESP: High ESP
(90/120/180Pa)

MEDIUM ESP TYPE (AC MOTOR TYPE)
RPIM-HNAUNQ



· Cooling Capacity:
2.2-7.1kW ESP: Medium ESP
(50/80Pa for 0.8-2.5HP class)

LOW ESP TYPE (AC MOTOR TYPE)
RPIL-HNAUNQ



· Cooling Capacity:
2.2-16.0kW
ESP: Low ESP (30Pa for
0.8-2.5HP class, 60Pa for
3.0-6.0HP class)

COMPACT TYPE (DC MOTOR TYPE)
RPIZ-HNDTSQ

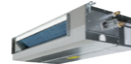

· Cooling Capacity:
2.2-7.1kW Fan air flow rate
up to 6 taps (DC motor
model only)
ESP: 10/30Pa

COMPACT TYPE (AC MOTOR TYPE)
RPIZ-HNATNQ

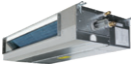

· Cooling Capacity:
2.2-7.1kW
ESP: 10/30Pa



CASSETTE

4-WAY CASSETTE TYPE (DC MOTOR TYPE)
RCI-FSRP



· Neutral White, Black, Gray and Beige options
· Reasonable offering to meet your comfort and operation

4-WAY CASSETTE TYPE + SMART SENSORS
RCI-FSRP + P-AP160NAE2



· Adaptive comfort for real life by multiple advanced comfort settings

4-WAY CASSETTE TYPE
RCI-FSKDNQ



· Economic yet efficient solution for your commercial indoor space

Silent-Ionic™
P-GP160NAP, P-GP160NAPU

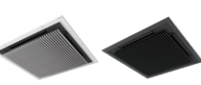

· The indoor air conditioning unit that makes a statement without making "noise"

4-WAY CASSETTE COMPACT TYPE (DC MOTOR TYPE)
RCIM-FSRE



· Compact 600x600mm fits a standard ceiling grid, allowing it to be easily incorporated between lighting panels

2-WAY CASSETTE TYPE (DC MOTOR TYPE)
RCD-FSR



· Ideal for long, narrow spaces
· Install in the center of the room, it ventilates lengthways to provide a consistent temperature

1-WAY CASSETTE TYPE (DC MOTOR TYPE)
RCS-FSR



· Ideal for smaller or narrow spaces, the 1-Way Cassette can be installed in a corner or on the window side of the room

OTHERS

WALL MOUNTED TYPE (DC MOTOR TYPE)
RPK-FSRM



· More precise and tailored comfort for you

WALL MOUNTED TYPE (DC MOTOR TYPE)
RPH-HNBSUQ



· Economic choice for any type of room
· Display set-temperature and operation mode on front cover by LED

FLOOR/CEILING CONVERTIBLE TYPE (AC MOTOR TYPE)
RPF-CFSNQ



· A functional solution for performance and practicality

CEILING SUSPENDED TYPE (DC MOTOR TYPE)
RPC-FSR



· Easily installed in spaces where there is no ceiling cavity or available floor space

FLOOR CONCEALED TYPE (AC MOTOR TYPE)
RPF-FSNQ



· Can be installed in floor cavities and walls

SOLUTIONS TO BE MEMORIZED TEMPERATURE MANAGEMENT FOR SUPERIOR COMFORT



Set your comfortable temperature not only for "Room" but also for "Air" in cooling operation. To make your room reach to the desired temperature faster, the discharged air from the indoor unit can be sometimes much cooler, causing discomfort at the beginning of operation. Now, you can choose "discharge air temperature = your own comfort level", as you like, by our Advanced color wire remote controller PC-ARFG1 & Advanced wired remote controller PC-ARF1. You can be in comfort and avoid cold draft from the moment when cooling operation starts, while the room gently cools down.

Potential Discomfort



GentleCool: OFF

GentleCool → No Cold Draft



GentleCool: LOW

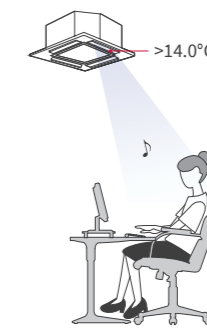

GentleCool: MED

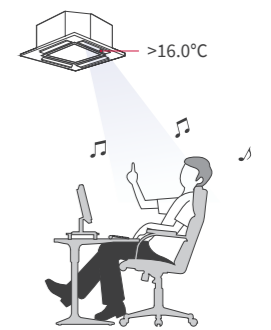

GentleCool: HIGH



CROWDSENSE

Adjusting capacity by predicting room temperature changes due to an increase or decrease in human activity

The motion and radiant temperature sensors detect changes in the number of people in the area and changes in the heat source and predict changes in room temperature. This CROWDSENSE feature activated by "Predictive crowd adjustment mode" adjusts the air conditioning capacity and suppresses fluctuations in room temperature.

- It may not be effective when operating multiple indoor units.
- This feature may not work if the variation in the number of people is minimal or if the heat source is small.
- When the room temperature is high and the temperature difference between the radiant temperature of the floor or wall and the surface temperature of the human body is small, it may not be possible to estimate the variation in the number of people. (When the room temperature is about 30° C during the cooling process in summer, etc.)
- If the number of people decreases whilst heating is in process, this control will not work.

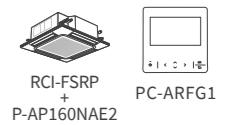

During the cooling function

If there is a lot of change in the number of people, such as during a meeting, the capacity is adjusted by predicting changes in room temperature.

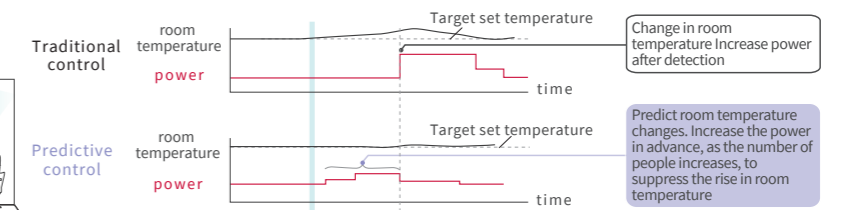

During the heating function

If there is a lot of change in the number of people, such as during a meeting, the capacity is adjusted by predicting changes in room temperature.

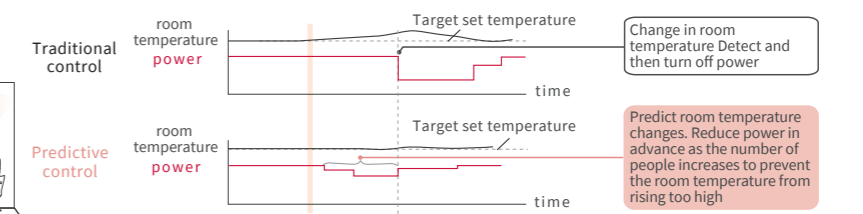

SOLUTIONS TO BE MEMORIZED

TEMPERATURE MANAGEMENT FOR SUPERIOR COMFORT

FEETWARM

INTELLIGENT COMFORT WITH OPTIONAL SENSOR

Airflow heat control raises the temperature in the foot area

Activated by [FeetWarm heat air control] in comfort setting, in the heating operation, "FEETWARM" feature improves the reaching distance of warm, as well as suctions low temperature air in the room efficiently. "FEETWARM" feature raises the temperature in the foot area compared to conventional control. In addition, since warm air is blown downwards in a more effective way, this feature is effective even in a large spaces.

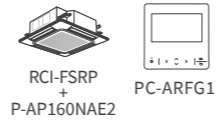
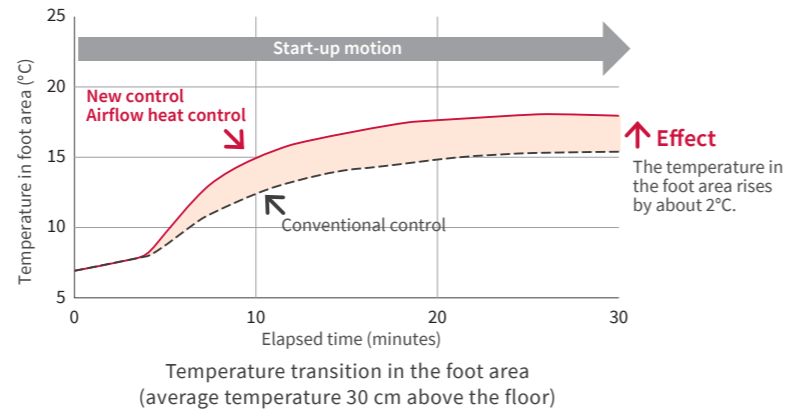

BETTER WARMTH IN THE ROOM

(1) Start-up motion

When the radiant temperature sensor detects that "the area around your feet is cold", 4-way cassette closes two opposite louvers¹ and narrows the airflow area, to concentrate the air volume in the other two louvers and make the underflow air stronger². This increases the air speed and makes it easier for warm air to reach the floor. In addition, low temperature air is efficiently suctioned via the center air-inlet grill near the two opposite louvers that are currently closed. Under this Start-up motion, the operation of this close & underflows in two louvers is changed alternately every 3 minutes, so that the temperature of your foot area in the room can be quickly warmed up.

¹ Under this "FEETWARM" feature, the gap of closed louver is a bit wider than the gap in operation-off.
² In the case of underflow, the air may hit your body directly, possibly causing you to feel cold a bit.

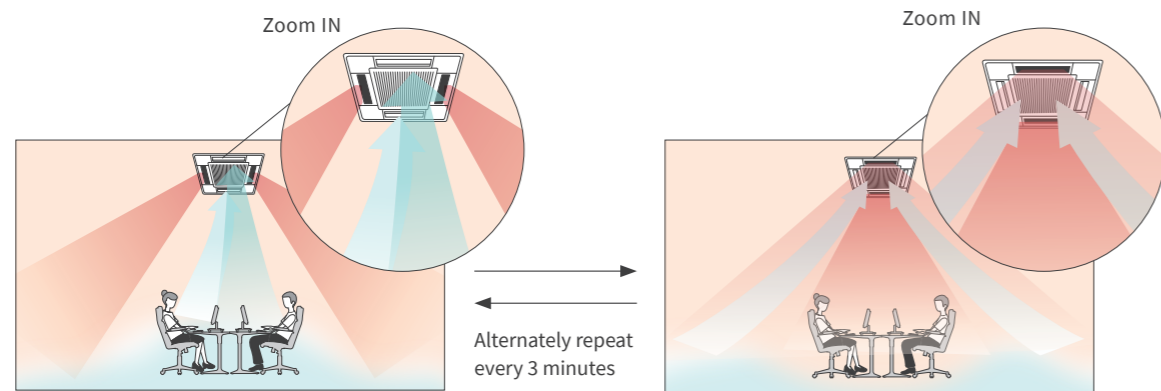
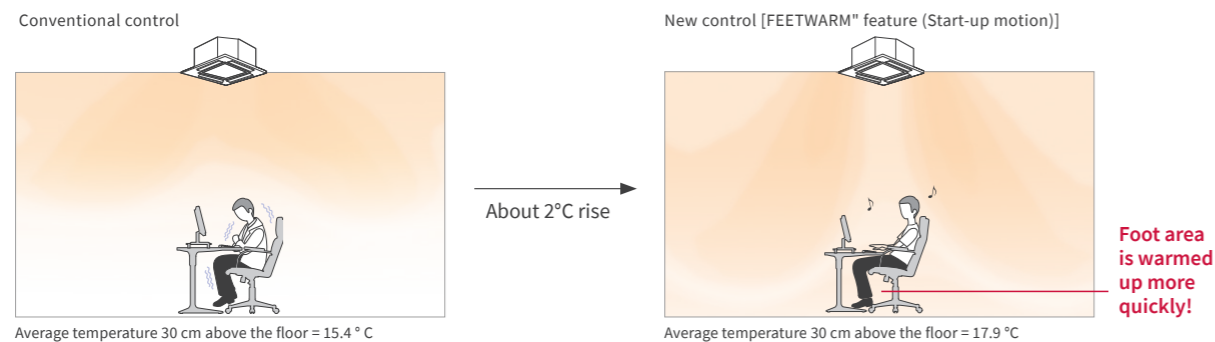

Image: Effect of start-up motion (temperature distribution near the foot area 30 minutes after starting the heating function) [Image based on calculation results]



(2) Temperature unevenness suppression motion

When the radiant temperature sensor detects that "the area around your feet is NO LONGER cold", this "FEETWARM" feature is shifted from "Start-up motion" to "Temperature unevenness suppression motion", which is to circulates the air flow more effectively in order to suppress the temperature unevenness in the foot area. 4-way cassette operates in Auto-Swing mode by letting 3 louvers open, while closing only one remaining louver. To do so, 4-way cassette can suction the lower cold temperature more efficiently, and help warm air circulate inside the room.

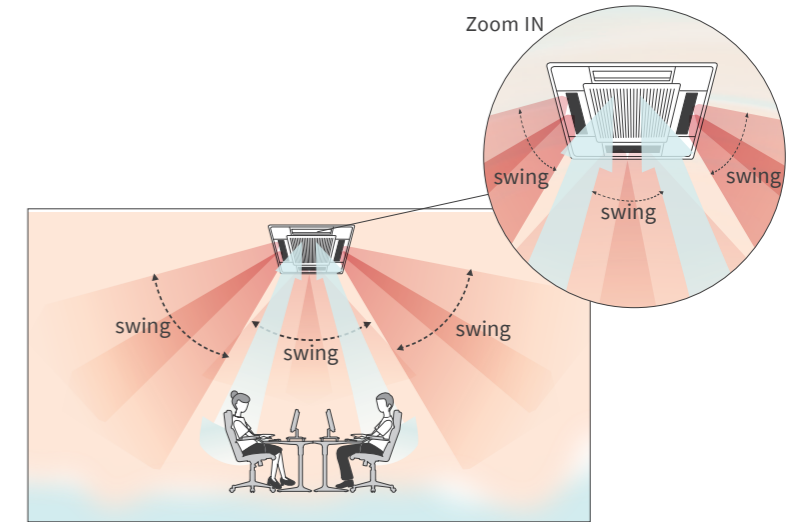
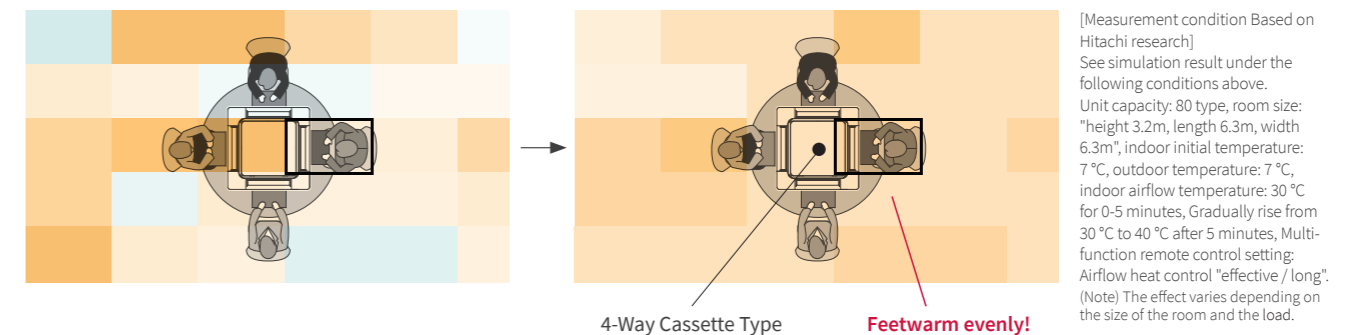

Image: Effect of temperature unevenness suppression motion (temperature distribution around the foot area)

Start-up Motion vs 20 minutes after temperature unevenness suppression motion



SOLUTIONS TO BE MEMORIZED TEMPERATURE MANAGEMENT FOR SUPERIOR COMFORT

DIRECT - INDIRECT AIRFLOW CONTROL

The presence or absence of human activity is detected through our advanced "motion sensor" which can sense the area by 4 zones, and the air flow direction is automatically adjusted for each zone.

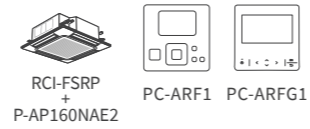

The air conditioning sensing area is divided into 4 zones through motion sensor. Each zone corresponds to ONE louver. Selecting "Indirect" or "Direct" automatically adjusts the direction of the air flow¹ for each zone with human activity.

¹ In case of "absence" area, air is blown out the way PC-ARFG1 is set up.
(Note) Concerning "Motion Sensor"

- If movement is little even when the room is occupied, "Motion Sensor" may not be able to detect the activity and it can operate as "absence" case.
- If an object with a temperature different from the surrounding temperature is in motion, it may be erroneously detected as human activity.

INDIRECT AIR DISTRIBUTION

Conditioning the air by horizontal airflow only so that people won't get hit by the direct air blow

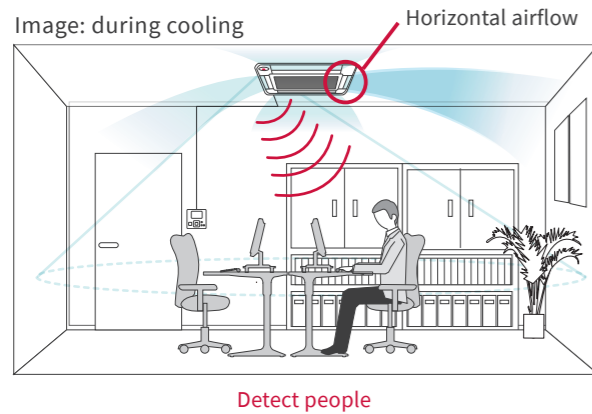

DIRECT AIR DISTRIBUTION

Conditioning the air by Auto-Swing airflow so that people can feel the direct cold air

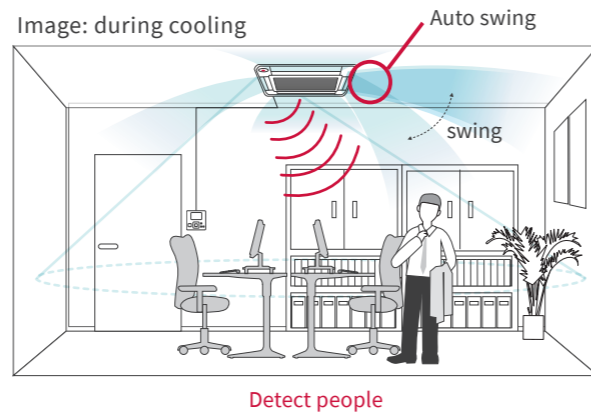

FLOORSENSE COOL

Detects the temperature near the floor to reduce overcooling

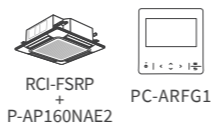

When the room has undergone prolonged cooling, the radiant temperature near the floor is detected and the air flow is automatically reduced, thus reducing the air conditioning capacity and preventing overcooling.¹

- ¹ When a group of people return to the room or the room temperature rises due to sunlight, the cooling operation returns to normal.
² Air flow contact varies depending on the capacity of the indoor unit and the height of the ceiling.

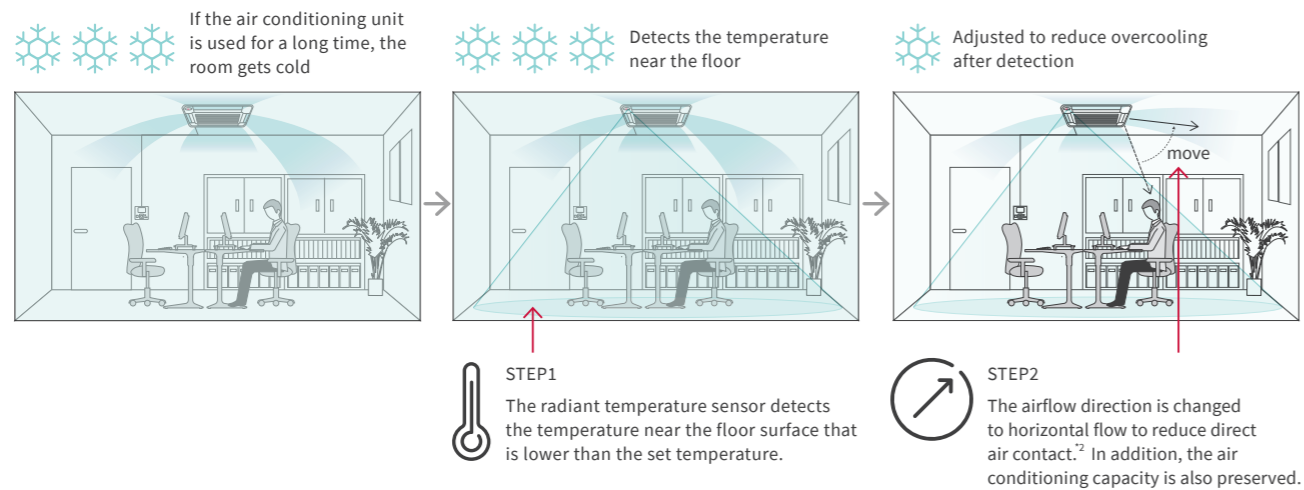

SOLUTIONS TO BE MEMORIZED FOR YOUR SMARTER OPERATION

AUTO MOTION-SENSOR CONTROL

The optional motion sensor enables extra energy savings by sensing the degree of activity in a room and automatically adjusting the air output to suit.



Image

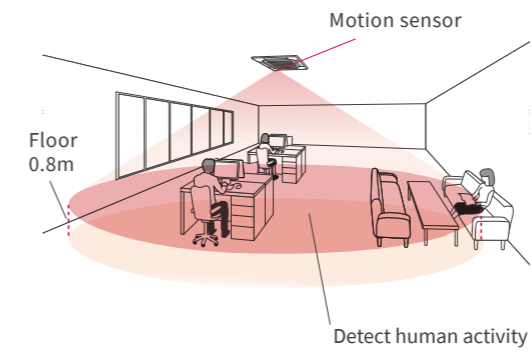

How does it work?

Detects the amount of human activity and activates auto-save.

<example>

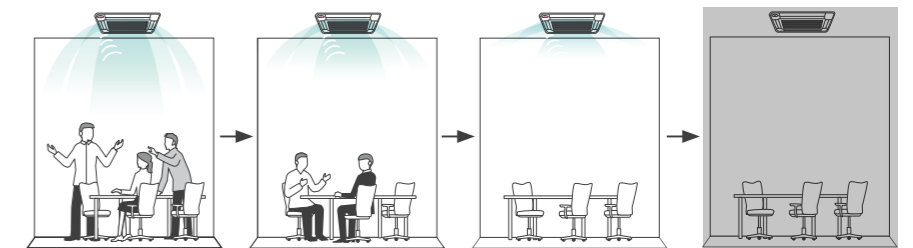

SETBACK MODE FOR HOTEL APPLICATION

Off set the temperature when the space is not occupied reducing the power consumption

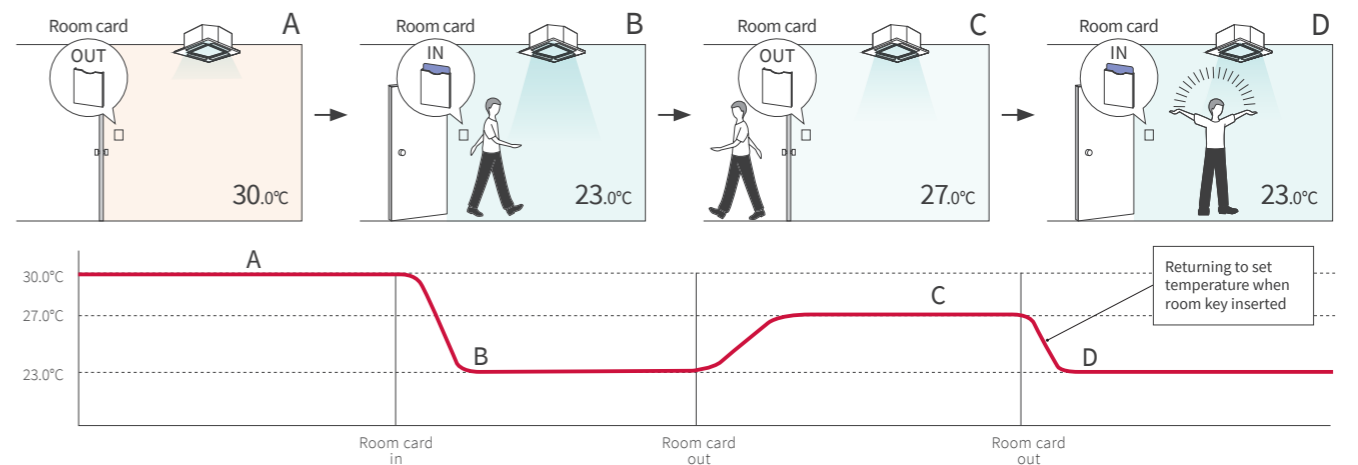

INDOOR AIR QUALITY

Live and work in harmony



Hitachi IAQ accessory Line-up

	01 ViroSense S filter	02 ViroSense Z2 filter	03 AQtiv-Ion Kit
Type of purchase	Now fitted as standard	Optional upgrade Model: F-160L-ZV	Optional upgrade Model: JK-LAZQ
For those who...	<ul style="list-style-type: none"> want to save additional cost want to create the cleaner indoor environment 	<ul style="list-style-type: none"> want to reduce the risk of secondary infection/pollution reduce spread of SARS-CoV-2 don't want to compromise airflow or additional noise 	<ul style="list-style-type: none"> Looking for low-maintenance non-intrusive ways of purifying air without installing separate purification units Looking for both pollutant and odor reduction solutions
Key Features	<ul style="list-style-type: none"> Lasts up to 5 years (12500h) Anti-virus (>99% inhibition) Anti-bacteria (>99% inhibition) Anti-mold (100% growth stop) 	<ul style="list-style-type: none"> Lasts up to 4 years (10000h) Quick & easy to install/change from existing filters Anti-virus (>99.7% inhibition): better than Ion filter Anti SARS-CoV-2 (>99.9% inhibition) Anti-bacteria (>99% inhibition) 	<ul style="list-style-type: none"> Lasts up to 6 years (15000h) Generates negative ions and emits through AC airflow, which binds to pollutants and odors, sending them harmlessly to the floor Plug & play; converts your ducted IDU into an air-purifying IDU Up to 96.85% capturing of Influenza virus Up to 74.90% removal of Formaldehyde

Standard-equipped filter ViroSense S filter

We have renewed our standard air filter for some of our Hitachi VRF indoor units with an leading-edge ion-technology, and, now it has THREE benefits for you & more assures indoor environment. Our STANDARD Air Filter with Ion Purification feature, ViroSense S filter, will catch & reduce them, then help create the cleaner indoor environment.

ANTI-VIRUS



over 99% Inhibition

ANTI-BACTERIA



over 99% Inhibition

ANTI-MOLD



100% growth stop

Testing information

[Anti-virus test]

Test Laboratory: Guangdong Detection Center of Microbiology
Test Report # 2021FM05006R01
Test Procedure: Based on ISO 18184:2019
Textiles - Determination of antiviral activity of textile products

[Anti-bacterial test]

Test Laboratory: Guangdong Detection Center of Microbiology
Test Report # 2021FM05006R01
Test Procedure: Based on JIS Z 2801:2010
Antibacterial products-Test for antibacterial activity and efficacy

[Anti-mold test]

Test Laboratory: Guangdong Detection Center of Microbiology
Test Report # 2021FM05006R01
Test Procedure: Based on JIS Z 2911:2018 (A)
Methods of test for fungus resistance

UNIT STANDARDIZED WITH VIROSENSE S FILTER

4-way Cassette (RCI-FSRP)					
TWIN-SENSE 4-way Panel White	Standard 4-way Panel White	Standard 4-way Panel Black	Silent-Iconic White	Silent-Iconic Auto-elevating grille White	Silent-Iconic Black
P-AP160NAE2	P-AP160NA3	P-AP160KA3	P-GP160NAP	P-GP160NAPU	P-GP160KAP
2-way Cassette (RCD-FSR)		1-way Cassette (RCS-FSR)		Ceiling Suspended (RPC-FSR)	
P-AP90DNA/P-AP160DNA		P-AP36CNA/P-AP56CNA/P-AP80CNA		RPC-1.5FSR~6.0FSR	

Cooling & Heating for the additional filter purchase, it is treated as "service part". Please consult your distributors.



ViroSense Z2 filter



Optional accessory filter
ViroSense Z2 filter

Model: F-160L-ZV

ViroSense Z2 filter can help reduce the risk of secondary pollution and infection in a room. We have confirmed the proven effect that can inhibit certain viruses attached to the air conditioner's filter already before, and in 2022, we have confirmed that it can inhibit the SARS-CoV-2 as well under the laboratory test.

BENEFITS



SARS-CoV-2 Inhibition by over 99.9%

The efficiency of the ViroSense Z2 filter against SARS-CoV-2 been confirmed with inhibition rate up to more than 99.9%.



Virus Inhibition by over 99.7%

The efficiency of the ViroSense Z2 filter against certain viruses has been confirmed with inhibition rate up to more than 99.7%.



Bacteria removal by over 99%

Efficiency of ViroSense Z2 filter against Certain types of Bacterial has been confirmed too with inhibition rate up to more than 99%.



Life span of up to 4 years

With regular maintenance and cleaning of the filter, the filter can have a life span of up to 4 years.



Quick anti-virus transformation

Your existing 4-way cassette panel can be quickly adapted for the anti-virus version, once you change your existing filter to the ViroSense Z2 filter. The same, usual attachment!

EFFICIENCY PROVEN

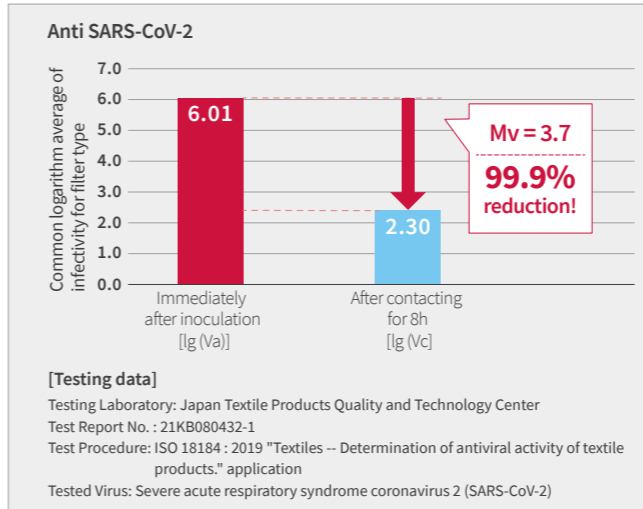

Anti Virus

[Testing data]

Testing Laboratory: Japan Textile Products Quality and Technology Center
Test Report No. : 20KB-070036
Tested Target: Feline infectious peritonitis virus ATCC VR-2127
Test Procedure: Based on ISO 18184; Textiles -- Determination of antiviral activity of textile products
Effect: Antiviral activity value (Mv) is at least 2.6 (>99.7% inhibition ratio)

Anti Bacteria

[Testing data]

Testing Laboratory: Kaken Test Center
Test Report: OS-20-09344-1
Test target: (1) Staphylococcus aureus ATCC 6538 (2) Klebsiella pneumoniae ATCC 4352
Test procedure: ISO 20743:2013 (Textiles - Determination of antibacterial activity of textile products)
Effect: Antibacterial activity ratio is at least (1) 2.6 (>99% death ratio) (2) 3.1 (>99.9% death ratio)

COMPATIBLE INDOOR UNITS WITH VIROSENSE Z2 FILTER

4-way Cassette (RCI-FSRP)						4-way Cassette (RCI-FSKDNQ)
TWIN-SENSE 4-way Panel White	Standard 4-way Panel White	Standard 4-way Panel Black	Silent-Iconic White	Silent-Iconic Auto-elevating grille White	Silent-Iconic Black	Standardized Panel
P-AP160NAE2	P-AP160NA3	P-AP160KA3	P-GP160NAP	P-GP160NAPU	P-GP160KAP	(Standard Equipped)

INDOOR AIR QUALITY

Live and work in harmony

Optional accessory filter
AQtiv-Ion Kit

Model: JK-LZAQ

Combine your air conditioner with AQtiv-Ion Kit, and provide a better and healthier indoor environment.

Efficient combination with air conditioning

As AQtiv-Ion Kit is integrated into the air conditioning system, AQtiv-Ion Kit does not require its own fan, but uses the airflow from the air conditioner instead. That means, your new air purification device has minimal impact on the noise level and energy consumption, as it fits inside the pre-installed air conditioner.



AQtiv-Ion Kit

COMMON FACTORS AFFECTING INDOOR AIR QUALITY



Various pathogenic factors including bacteria and certain viruses caused by insufficient ventilation.



Breeding of bacteria, mold and damage to household items, allergies caused by high humidity in wet season.



Formaldehyde, ammonia, benzene and a variety of volatile organic compounds released by decoration materials.



Second-hand smoking and kitchen oil fume.



Dust and mites from fabrics, such as beddings and pet dander might cause allergies.



HOW AQTIV-ION KIT WORKS



Inactivation of SARS-CoV-2 by more than 99.9%



Up to 96.85% capture of certain viruses and bacteria



Down to PM0.3 micro particle removal



Removal of pollutants



Active oxygen generation

AQTIV-ION KIT TECHNOLOGY

The AQtiv-Ion Kit generates negative ions, which when released into the air, combine with the oxygen (O₂) naturally present in the air. These newly created oxygen molecules trap the impure particles, certain viruses and bacteria and deactivate them.

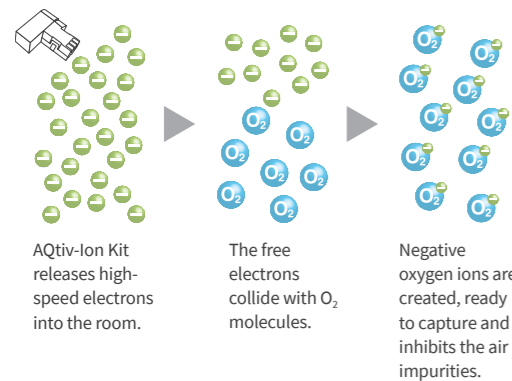

Fight Against The Multiple Invisibles

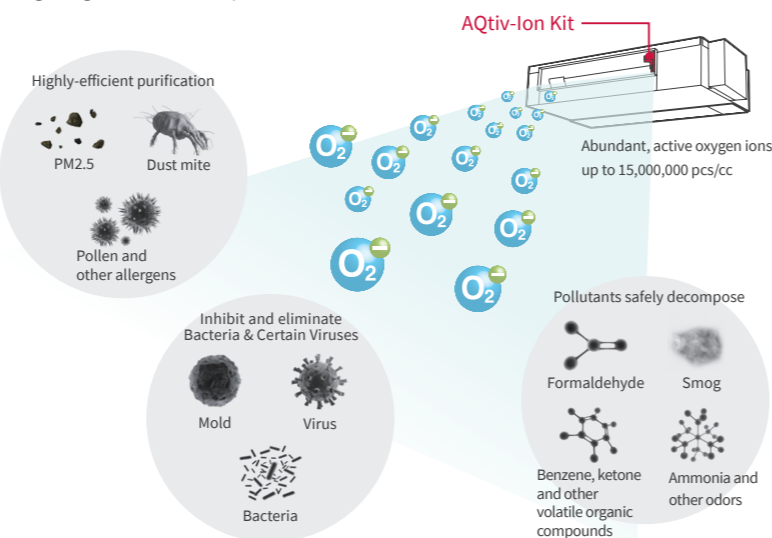

AQTIV-ION KIT DEACTIVATION PERFORMANCE

SARS-CoV-2 -99.9% (Inhibition rate)	Escherichia coli -96.64% (Inhibition rate)	Influenza virus -96.85% (Removal rate)	Staphylococcus aureus -93.88% (Inhibition rate)	PM2.5 -94.46% (Removal rate)	Formaldehyde -74.90% (Removal rate)	Ammonia -73.20% (Removal rate)
--	---	---	--	---	--	---

AQTIV-ION KIT APPLICATIONS

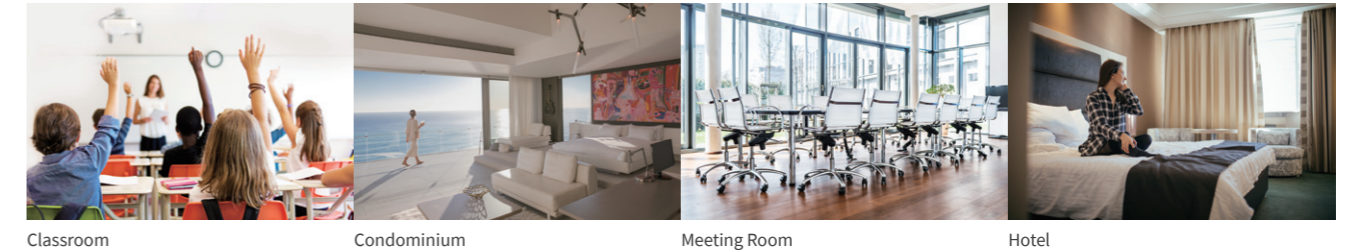

HOW TO INSTALL?

Plug and play!
Up to your installation condition, you can choose from two options for AQtiv-Ion Kit to be fixed to.

(1) Inside the indoor unit (air outlet)

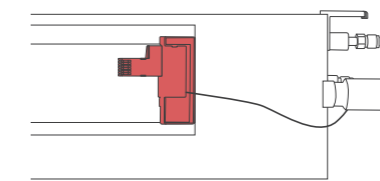

(2) Inside the air duct (air outlet)

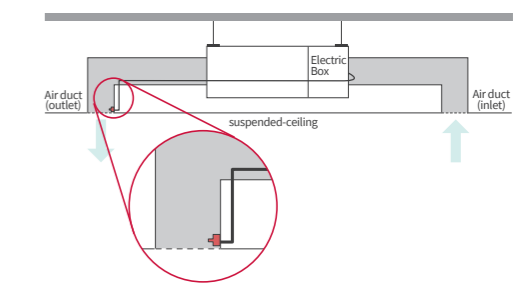

TECHNICAL SPECIFICATIONS

Model	JK-LZAQ
Wiring Length	1 meter
Rated power supply	220~240V, 50/60Hz
Electrical Power consumption	(Max) 3W
Operating temperature	-10~50 °C
Operating humidity	20~80%RH
Value of negative ion amount	15,000,000 pcs/cc
Certification	CE/CB

TESTING

[Escherichia coli] [Staphylococcus aureus]	
Laboratory	Guangdong Detection Center of Microbiology
Testing standard	GB 21551.3-2010 Appendix A
Test Report	2019FM10157R01
[PM2.5]	
Laboratory	Guangdong Detection Center of Microbiology
Testing standard	APIAC/LM 01-2015
Test Report	2019FM10157R02
[Influenza virus]	
Laboratory	Guangdong Detection Center of Microbiology
Testing standard	Regulation of disinfection technique in healthcare settings <2002, 2-1-3>
Test Report	2019FM10157R03
[Formaldehyde] [Ammonia]	
Laboratory	Guangdong Detection Center of Microbiology
Testing standard	QB/T2761-2006 etc
Test Report	2019FM10157R04

Please consult your Hitachi Cooling & Heating representative for more details concerning the test reports.

COMPATIBLE INDOOR UNITS WITH AQTIV-ION KIT



(*) For RPI-8.0/10.0FSNQH, please fix the AQtiv-Ion Kit to the indoor unit air-outlet.

DUCTED

KEY INFORMATION

FEATURES TO SUIT YOUR PROJECT SPACE

The new SET FREE Σ range offers our widest choice of indoor units to give you the versatility to complement any interior.



HIGH ESP TYPE (AC MOTOR TYPE)
[RPIH-HNAUNQ]

- High ESP (90/120/180Pa)
- Space saving design thanks to a height of only 300mm
- Compatible with AQtiv-Ion Kit (Optional accessory)



MEDIUM ESP TYPE (AC MOTOR TYPE)
[RPIM-HNAUNQ]

- Medium ESP (50/80Pa for 0.8-2.5HP class)
- Space saving design thanks to a height of only 270mm
- Compatible with AQtiv-Ion Kit (Optional accessory)



LOW ESP TYPE (AC MOTOR TYPE)
[RPIL-HNAUNQ]

- Low ESP (30Pa for 0.8-2.5HP class, 60Pa for 3.0-6.0HP class)
- Space saving design thanks to a height of only 270mm (0.8-2.5HP class) or 350mm (3.0-6.0HP class)
- Compatible with AQtiv-Ion Kit (Optional accessory)

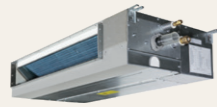

COMPACT TYPE (DC MOTOR TYPE)
[RPIZ-HNDTSQ]

- Ideal for installation over the closet or windows thanks to the up to the compactness with 192mm height
- Drain-pump with 900mm lift as standard optional part
- Quiet operation level (as low as 20dB(A))
- Fan air flow rate up to 6 taps (DC motor model only)
- Compatible with AQtiv-Ion Kit (Optional accessory)

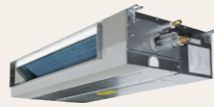

COMPACT TYPE (AC MOTOR TYPE)
[RPIZ-HNATNQ]

- Ideal for installation over the closet or windows thanks to the up to the compactness with 192mm height
- Drain-pump with 900mm lift as standard optional part
- Quiet operation level (as low as 20dB(A))
- Compatible with AQtiv-Ion Kit (Optional accessory)

COMPARISON

IDU Category	Cooling (kW)	2.2	2.8	3.6	4.0	4.3	5.0	5.6	6.3	7.1	8.0	8.4	9.0	11.2	14.0	14.2	16.0
HIGH ESP TYPE (AC MOTOR TYPE) [RPIH-HNAUNQ]												●	●	●		●	●
MEDIUM ESP TYPE (AC MOTOR TYPE) [RPIM-HNAUNQ]		●	●	●		●	●	●	●	●							
LOW ESP TYPE (AC MOTOR TYPE) [RPIL-HNAUNQ]		●	●	●		●	●	●	●	●		●	●	●		●	●
COMPACT TYPE (DC MOTOR TYPE) [RPIZ-HNDTSQ]		●	●	●	●		●	●	●	●						●	●
COMPACT TYPE (AC MOTOR TYPE) [RPIZ-HNATNQ]		●	●	●	●		●	●	●	●							

DUCTED

FEATURES COMPARISON

	HIGH ESP TYPE (AC motor)	MEDIUM/LOW ESP TYPE (AC motor)	COMPACT TYPE (DC motor)	COMPACT TYPE (AC motor)
Model	RPIH-HNAUNQ	RPIM-HNAUNQ RPIL-HNAUNQ	RPIZ-HNDTSQ	RPIZ-HNATNQ
Temperature Setting Rate	1.0°C	1.0°C	1.0°C	1.0°C
Indoor Fan Speed	3 taps	3 taps	6 taps	3 taps
Louver Direction	-	-	-	-
Individual Louver Setting	-	-	-	-
Auto Louver Setting	-	-	-	-
Dry mode Availability	●	●	●	●
Setback (Away Function)	-	-	-	-
Cold Draft Prevention Availability (*1)(*4)	●	●	●	●
Comfort setting Control Cool Air (GentleCool) (*2)	-	-	-	-
Direct/Indirect louver direction in COOL	-	-	-	-
Direct/Indirect louver direction in HEAT	-	-	-	-
FeetWarm air flow control	-	-	-	-
FloorSense Cool air flow control	-	-	-	-
Power Saving with Motion Sensor (*2)	-	-	-	-
Outdoor Unit capacity control (*2)	Peak cut control	-	-	-
	moderate control	-	-	-
Indoor Unit Rotation Control (*2)	Indoor Unit Address	-	-	-
	Indoor Air Temperature difference	-	-	-
Automatic Fan Operation	●	●	●	●
Quick Function (*2)	-	-	-	-
Daylight Saving Time	●	●	●	●
Power Consumption visualization (*2)	-	-	-	-
Weekly Schedule Setting	●	●	●	●
Power-Saving Setting (*2)	-	-	-	-
Dirty Filter Notice Availability	●	●	●	●
Check Menu	Sensor Condition Check	●	●	●
	Model Display (*2)	-	-	-
	Indoor/Outdoor PCB Check	●	●	●
	Alarm History Display	●	●	●
Motion Sensor	-	-	-	-
Receiver Kit for wireless remote controller	PC-RLH11 PC-ALHZ1	PC-RLH11 PC-ALHZ1	PC-RLH11 PC-ALHZ1	PC-RLH11 PC-ALHZ1
Drain-up mechanism availability	DUPI-361Q	DUPI-131Q DUPI-361Q	● (*3)	● (*3)
Air filter	KW-PP9/10Q	KW-PP7/ 8/9/10Q	KW-PP5Q KW-PP6Q KW-PP12Q	KW-PP5Q KW-PP6Q KW-PP12Q
AQtiv-Ion Kit	●	●	●	●

(*1) This function is utilized to prevent cold discharged air at start-up of heating operation, after defrosting operation, etc.

(*2) Advanced wired remote controller PC-ARF1 needs to be connected.

(*3) Included as standard equipment.

(*4) Please consult your distributor.

AQtiv-Ion Kit



Leads to the better Indoor Air Quality

Features

- Up to 96.85% capture of viruses and bacteria
- Down to PM0.3 micro particle removal
- Pollutant removal
- Active oxygen generation
- Inactivation of SARS-CoV-2 by more than 99.9%

DUCTED

HIGH ESP TYPE (HIGH EXTERNAL STATIC PRESSURE TYPE) (AC MOTOR TYPE) [RPIH-HNAUNQ]

FEATURES AND BENEFITS

- 1) High ESP (90/120/180Pa)
- 2) Space saving design thanks to a height of only 300mm
- 3) Flexible installation options allow for multiple configurations

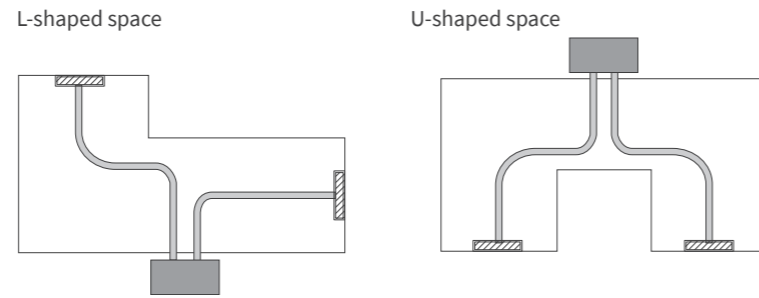

- 4) Optional Drain Pump
Drain-up mechanism can be supplied as optional part.

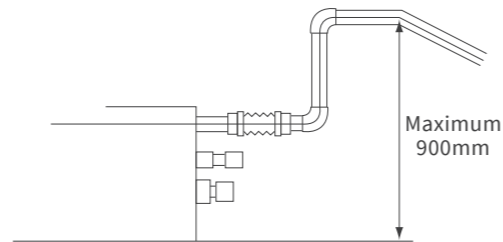

MEDIUM ESP TYPE (MEDIUM EXTERNAL STATIC PRESSURE TYPE) (AC MOTOR TYPE) [RPIM-HNAUNQ]

FEATURES AND BENEFITS

- 1) Medium ESP (50/80Pa for 0.8-2.5HP class)
- 2) Space saving design thanks to a height of only 270mm

- 3) Optional Drain Pump
Drain-up mechanism can be supplied as optional part.

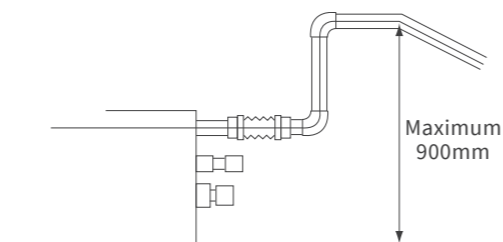

LOW ESP TYPE (LOW EXTERNAL STATIC PRESSURE TYPE) (AC MOTOR TYPE) [RPIL-HNAUNQ]

FEATURES AND BENEFITS

- 1) Low ESP (30Pa for 0.8-2.5HP class, 60Pa for 3.0-6.0HP class)
- 2) Space saving design thanks to a height of only 270mm (0.8-2.5HP class) or 300mm (3.0-6.0HP class)

- 3) Optional Drain Pump
Drain-up mechanism can be supplied as optional part.

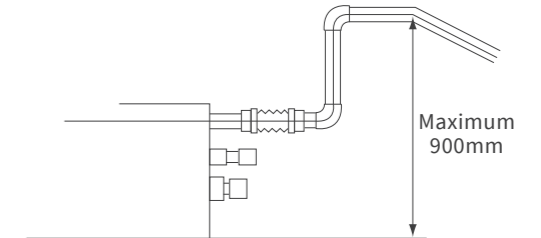

COMPACT TYPE (DC MOTOR TYPE) [RPIZ-HNDTSQ]

FEATURES AND BENEFITS

- 1) Ideal for installation over the closet or windows thanks to the up to the compactness with 192mm height
- 2) Drain-pump with 900mm lift as standard optional part
- 3) Quiet operation level (as low as 22.5dB(A))
- 4) Fan air flow rate up to 6 taps (DC motor model only)

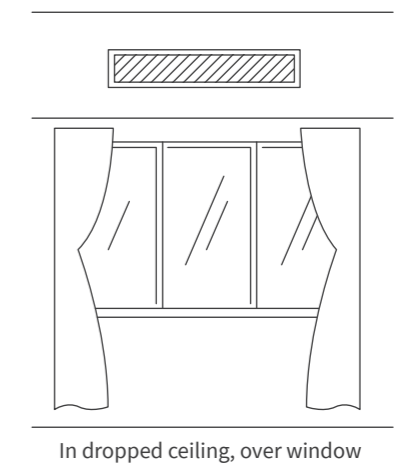
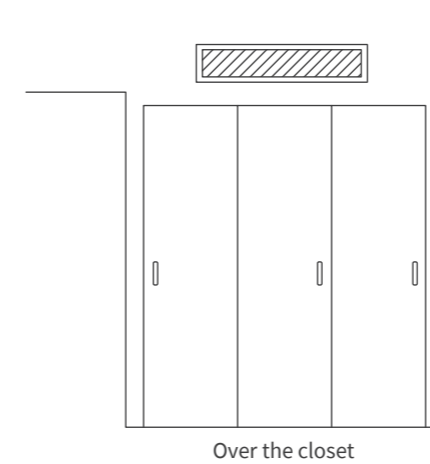

DUCTED

COMPACT TYPE

(AC MOTOR TYPE) [RPIZ-HNDTNQ]

FEATURES AND BENEFITS

- 1) Ideal for installation over the closet or windows thanks to the up to the compactness with 192mm height
- 2) Drain-pump with 900mm lift as standard optional part
- 3) Quiet operation level (as low as 20dB(A))
- 4) Fan air flow rate up to 6 taps (DC motor model only)

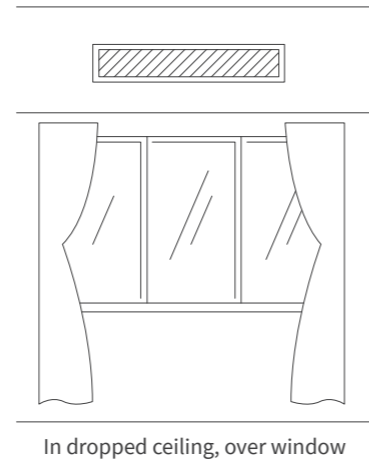
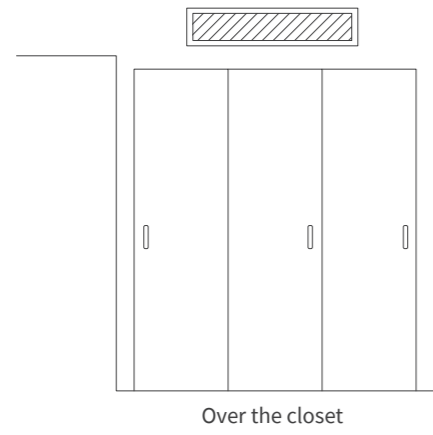

CASSETTE

KEY INFORMATION

FEATURES TO SUIT YOUR PROJECT SPACE

The new SET FREE Σ range offers our widest choice of indoor units to give you the versatility to complement any interior.

CASSETTE

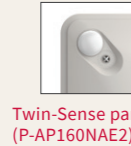

Silent-Iconic™

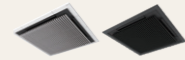

Color variation (RCI-FSRP)



Silent-Iconic™ with Elevation Grille

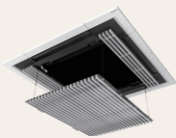

4-WAY CASSETTE TYPE (DC MOTOR TYPE) [RCI-FSKDNQ]

- With area of air distribution with 7 direction of louvers (distribution with distance available with optional parts (duct flange))
- Individual four-way louvers for greater comfort for individual users
- Ideal for a higher ceiling location for installation (up to 5.5m in cooling mode)
- Setback temperature control available, leading to better operation.
- GentleCool control to ensure you are not bothered by cold draft
- Compatible with ViroSense Z2 filter!



4-WAY CASSETTE COMPACT TYPE (DC MOTOR TYPE) [RCIM-FSRE]

- Made to give you greater design flexibility as the dimensions fit 600mm×600mm architectural module ceiling specifications
- Quiet operation level (as low as 24.5dB(A))
- Wide range of air flow rate ideal for high ceiling installation with 4.6m air blow down in cooling mode
- Setback temperature control available, leading to better operation.
- Motion sensor available for better energy saving operation
- GentleCool control to ensure you are not bothered by cold draft
- ViroSense S filter as standard!

2-WAY CASSETTE TYPE (DC MOTOR TYPE) [RCD-FSR]

- Motion sensor available for better energy saving operation
- Ideal for a higher ceiling location for installation (up to 4.6m in cooling mode)
- Individually operated louvers give room occupants more comfort
- Quiet operation level (as low as 27dB(A))
- Setback temperature control available, leading to better operation.
- GentleCool control to ensure you are not bothered by cold draft
- ViroSense S filter as standard!

1-WAY CASSETTE TYPE (DC MOTOR TYPE) [RCS-FSR]

- Motion sensor available for better energy saving operation
- Optimum air flow conditions are created by either downward air discharge or frontal air discharge (via optional grille) or a combination of both
- Quiet operation level (as low as 27dB(A))
- Setback temperature control available, leading to better operation.
- GentleCool control to ensure you are not bothered by cold draft
- ViroSense S filter as standard!

COMPARISON

IDU Category	Cooling (kW)	2.2	2.8	4.0	5.6	7.1	8.0	11.2	14.0	16.0
4-WAY CASSETTE TYPE (DC MOTOR TYPE) [RCI-FSRP, RCI-FSKDNQ]			●	●	●	●	●	●	●	●
4-WAY CASSETTE COMPACT TYPE (DC MOTOR TYPE) [RCIM-FSRE]		●	●	●	●	●				
2-WAY CASSETTE TYPE (DC MOTOR TYPE) [RCD-FSR]		●	●	●	●	●	●	●	●	●
1-WAY CASSETTE TYPE (DC MOTOR TYPE) [RCS-FSR]		●	●	●	●	●	●			

FEATURES COMPARISON

Model	4-WAY CASSETTE TYPE (DC MOTOR TYPE) [RCI-FSRP]	4-WAY CASSETTE TYPE (DC MOTOR TYPE) [RCI-FSKDNQ]	4-WAY CASSETTE COMPACT TYPE (DC MOTOR TYPE) [RCIM-FSRE]	2-WAY CASSETTE TYPE (DC MOTOR TYPE) [RCD-FSR]	1-WAY CASSETTE TYPE (DC MOTOR TYPE) [RCS-FSR]
Temperature Setting Rate	0.5°C/1.0°C	0.5°C/1.0°C	0.5°C/1.0°C	0.5°C/1.0°C	0.5°C/1.0°C
Indoor Fan Speed	4 taps	4 taps	4 taps	4 taps	4 taps
Louver Direction	7 (*4)	7 (*4)	7 (*4)	7 (*4)	7 (*5)
Individual Louver Setting	●	●	●	●	-
Auto Louver Setting	●	●	●	●	●
Dry mode Availability	●	●	●	●	●
Setback (Away Function)	●	●	●	●	●
Cold Draft Prevention Availability (*1)	●	●	●	●	●
Comfort setting Control Cool Air (GentleCool) (*2)	●	●	●	●	●
Direct/Indirect louver direction in COOL	●	-	-	-	-
Direct/Indirect louver direction in HEAT	●	-	-	-	-
FeetWarm air flow control	●	-	-	-	-
FloorSense Cool air flow control	●	-	-	-	-
ViroSense S filter as standard	P-AP160NAE2 P-AP160NA3 P-AP160KA3 P-GP160NAP P-GP160NAPU P-GP160KAP	-	-	P-AP90DNA P-AP160DNA	P-AP36CNA P-AP56CNA P-AP80CNA
Power Saving with Motion Sensor (*2)	●	●	●	●	●
Outdoor Unit capacity control (*2)	Peak cut control moderate control	● ●	● ●	● ●	● ●
Indoor Unit Rotation Control (*2)	Indoor Unit Address Indoor Air Temperature difference	● ●	● ●	● ●	● ●
Automatic Fan Operation	●	●	●	●	●
Quick Function (*2)	●	●	●	●	●
Daylight Saving Time	●	●	●	●	●
Power Consumption visualization (*2)	●	●	●	●	●
Weekly Schedule Setting	●	●	●	●	●
Power-Saving Setting (*2)	●	●	●	●	●
Dirty Filter Notice Availability	●	●	●	●	●
Check Menu	Sensor Condition Check Model Display (*2) Indoor/Outdoor PCB Check Alarm History Display	● ● ● ●	● - ● ●	● ● ● ●	● ● ● ●
Colored Decoration Panel availability	● (*6)	-	-	● (*6)	● (*6)
Motion Sensor	P-AP160NAE2	-	SOR-NEC	SOR-NED	SOR-NES
Receiver Kit for wireless remote controller	PC-ALH3	HR4A10NEWQ PC-ALH3	P-AP56NAMR PC-ALHC1	PC-ALHD1	PC-ALHS1
Drain-up mechanism availability	● (*3)	● (*3)	● (*3)	● (*3)	● (*3)
Flesh air intake accessory	● (*7)	-	● (*7)	● (*7)	● (*7)
Decoration Panel	P-AP160NAE2 P-AP160NA3 P-AP160KA3 P-GP160NAP P-GP160NAPU P-GP160KAP	Standard	P-AP56NAMR P-AP56NAMR	P-AP90DNA P-AP160DNA	P-AP36CNA P-AP56CNA P-AP80CNA
Design Panel Silent-Iconic	P-AP160NAE2 P-AP160NA3 P-AP160KA3 P-GP160NAP P-GP160NAPU P-GP160KAP	-	-	-	-
ViroSense Z2 filter (optional) compatible with	P-AP160NAE2 P-AP160NA3 P-AP160KA3 P-GP160NAP P-GP160NAPU P-GP160KAP	RCI-FSKDNQ	-	-	-
Normal Air Filter	F-71L-D1 F-160L-D1 B-160H3 (filter box)	-	-	F-90MD-K1 F-160MD-K1 B-90HD (filter box) B-160HD (filter box)	-

- (*1) This function is utilized to prevent cold discharged air at start-up of heating operation, after defrosting operation, etc.
- (*2) Advanced wired remote controller PC-ARF1 needs to be connected.
- (*3) Included as standard equipment.
- (*4) 7 steps are available by individual louver setting. 5 steps only in the operation of Cooling or Dry.
- (*5) 5 steps only in the operation of Cooling or Dry.
- (*6) 3 colors available (Beige, Grey and Black).
- (*7) Optional parts: Duct Adapter is available. Please consult your distributor.

ViroSense S filter



- Features
- New filter as standard
- Lasts up to 5 years (12500h)
- Anti-virus (>99% inhibition)
- Anti-bacteria (>99% inhibition)
- Anti-mold 100% growth stop

ViroSense Z2 filter



- Features
- Optional Accessory
- Lasts up to 4 years (10000h)
- Quick & easy to install/change from existing filters
- Anti-virus (>99.7% inhibition): better than Ion filter
- Anti SARS-CoV-2 (>99.9% inhibition)



Silent-Iconic™

4-Way Cassette Design Panel

A design panel in harmony with the space that responds to the needs of architectural designers



reddot winner 2021
best of the best

[Silent-iconic] receives Red Dot: Best of the Best for ground-breaking design quality



iF Design Award 2020
Award Winning
(Discipline: Product)



GOOD DESIGN AWARD 2020
Good Design Award
(Category: Equipment and facilities for professional use)



The design is well-matched to the space

It is designed to harmonize with the space by creating the central part to be a blind shaped air-inlet port and reducing its occupied presence by darkening the air-outlet port.

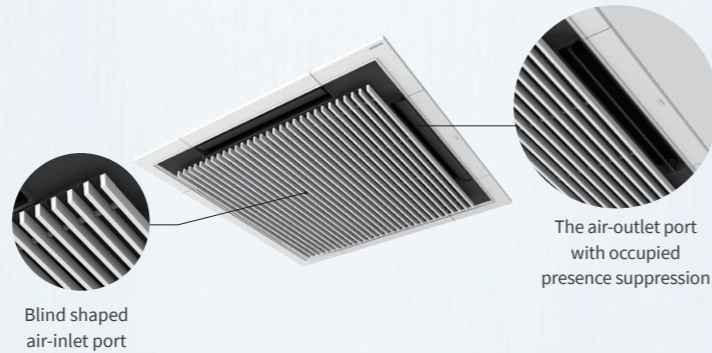

Tomohiko Sato

Hitachi, Ltd. Product Design Department, Senior Designer



The designer graduated from University in the United Kingdom and soon after, he joined a London based design studio, working across a wide variety of disciplines including furniture, interior and the public realm. Currently, he dedicates himself to air conditioning design, working as a Senior Designer in the Hitachi product design department in Hitachi, Ltd.

Try it with iPhone!!

In AR (Augmented Reality), you can see the image of "4-way Cassette Air Conditioner" and "Silent-Iconic™" installed in the actual space.



4-way Cassette Air Conditioner

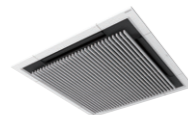

Silent-Iconic™ White

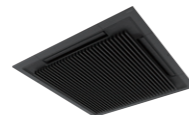

Silent-Iconic™ Black



Operating environment

[Device]	
iPhone ¹	iPhone 12 Pro / iPhone 12 Pro Max / iPhone 12 / iPhone 12mini / iPhone 11 Pro / iPhone 11 Pro Max / iPhone 11 / iPhone XS / iPhone XS Max / iPhone XR / iPhone X / iPhone 8 Plus / iPhone 8 / iPhone 7 Plus / iPhone 7 / iPhone 6s Plus / iPhone 6s / iPhone SE2 / iPhone SE
iPad ²	iPad Pro (all models) / iPad (6th generation) / iPad (5th generation)
[OS]	iOS ³ 12.1 or later
[Browser]	Safari ⁴ / Google Chrome ⁵ / Firefox ⁶



1. Scan the QR code¹⁷

and open the web page

Display the web page with a QR code, URL, etc.



2. Tap the icon

Tap the icon displayed at the bottom right of the 3D Viewer. If the icon is not displayed, please unhide it in Safari or check the OS version.



3. AR mode is activated

Hold out the camera toward the ceiling and get it to detect the environment by moving it in a circular motion. You may not be able to scan a single-colored ceiling so scan a place where objects such as downlights or ceiling ventilation fans are installed.







4. Adjustment of placement location

You can shift then move it with a single finger, and rotate or zoom it out/zoom it in with two fingers to adjust the size that fits the space. There is also a capture button, so you can take and share the pictures you have placed.

CASSETTE

4-WAY CASSETTE TYPE (DC MOTOR TYPE) [RCI-FSRP]

LINE-UP

Normal	Smart	Aesthetics	Maintenance
Standard P-AP160NA3	with motion sensor + radiant temperature sensor P-AP160NAE2	Color Panel Design Panel - Standard (Custom Order) Beige Gray Black Silent-Iconic™ White Black P-GP160NAP P-GP160KAP	Silent-Iconic™ with Elevation Grille P-GP160NAPU
			
(H×W×D) 40×950×950(mm)	(H×W×D) 40×950×950(mm)	Standard (H×W×D) 40×950×950(mm) Silent-Iconic™ (H×W×D) 52×950×950(mm)	(H×W×D) 52×950×950(mm)

Twin-Sense Cassette

Adaptive comfort for real life

GENTLECOOL
(standard feature) To make your room reach to the desired temperature faster, the discharged air from the indoor unit can be sometimes much cooler, causing discomfort at the beginning of operation.

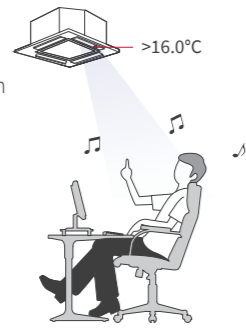

FEETWARM
(with radiant temperature sensor) optimization of IDU air flow direction during heating mode by to make sure that leg zone is consistently heated



FLOORSENSE COOL
(with radiant temperature sensor) optimize both IDU air flow & cooling capacity to prevent floor overcooling

Image: during cooling
Horizontal airflow
Detect people

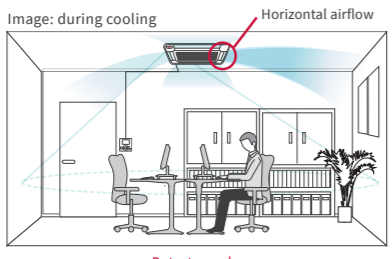

CROWDSENSE
(with motion sensor + radiant temperature sensor) In case of occupancy changes, predictive adjustment of cooling or heating operation to prevent fluctuations of indoor temperature due to human body heat.

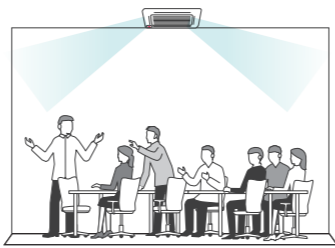

4-WAY CASSETTE COMPACT TYPE (DC MOTOR TYPE) [RCIM-FSRE]

FEATURES AND BENEFITS

1) Compact

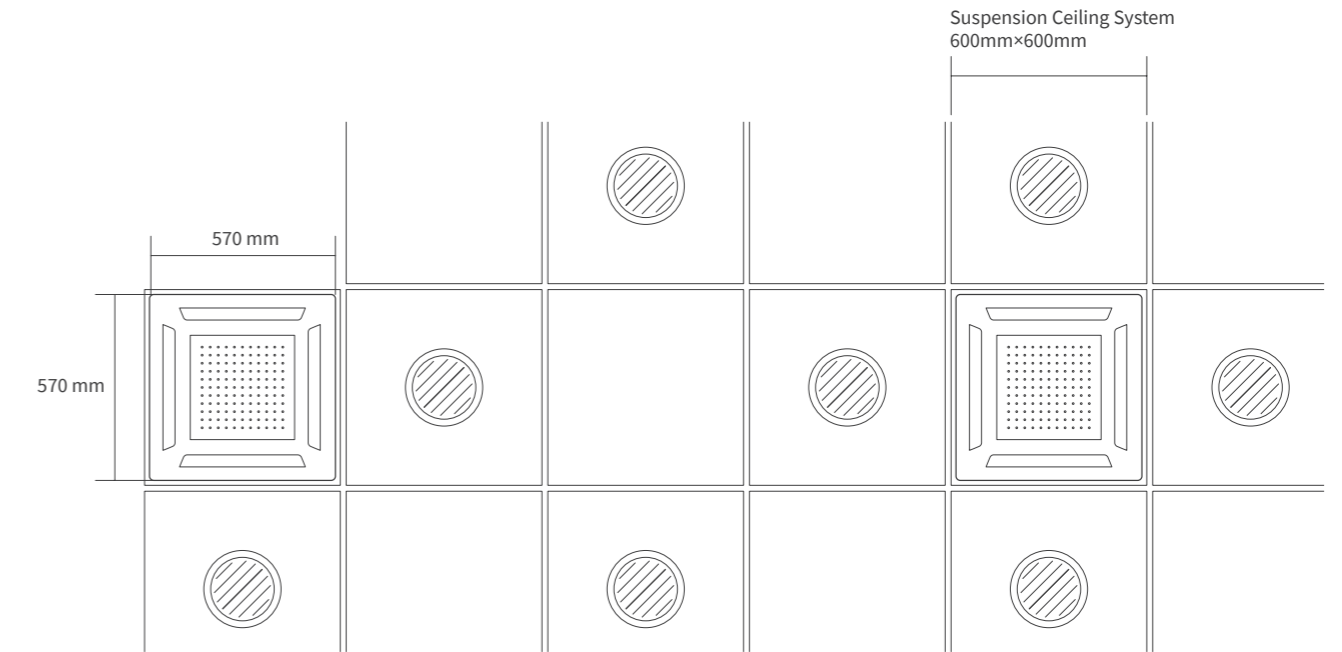

The compact 600×600mm footprint fits a standard ceiling grid, allowing it to be easily incorporated between lighting panels, being ideal for the small place installation!

2) Top-class silent operation As quiet as gentle breeze

IDU Capacity HP(Class)	0.8	1	1.5	2	2.5
Sound pressure level (dB(A))	24.5	24.5	27.5	31	35

*Air flow rate: Lo



3) Aesthetics

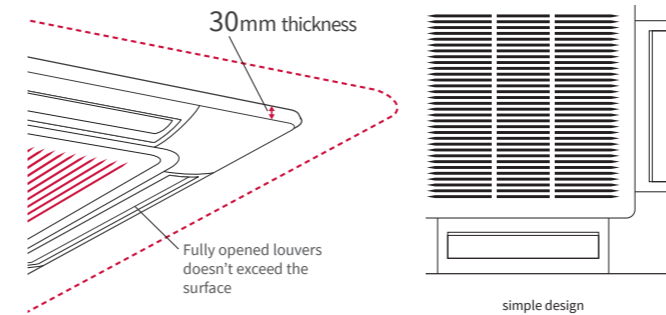

4) Suitable for high ceiling space Standard drain-pump with 850mm lift

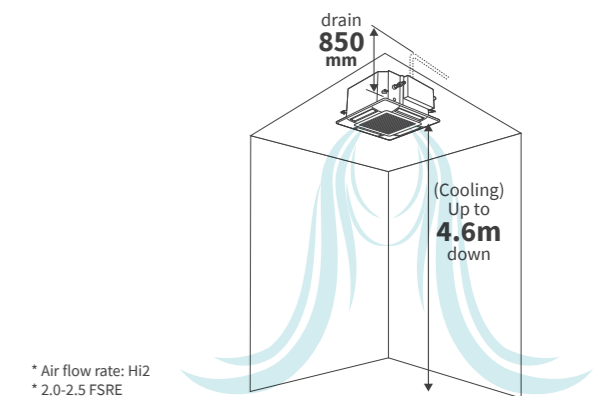

* Air flow rate: Hi2
* 2.0-2.5 FSRE

CASSETTE

2-WAY CASSETTE COMPACT TYPE

(DC MOTOR TYPE) [RCD-FSR]

FEATURES AND BENEFITS

1) Control air flow with individual louvers

Suitable environment can be achieved for each person

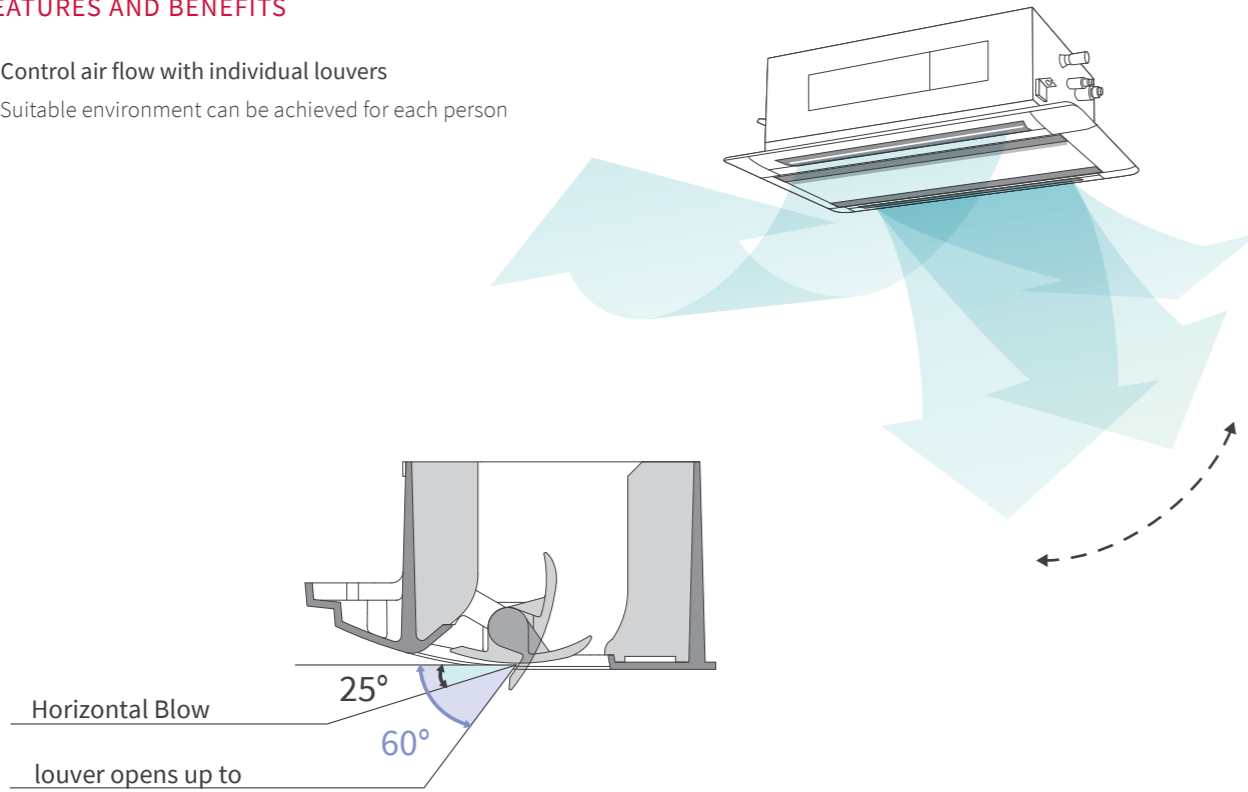

2) The height of the space for installing the unit can be fine-tuned

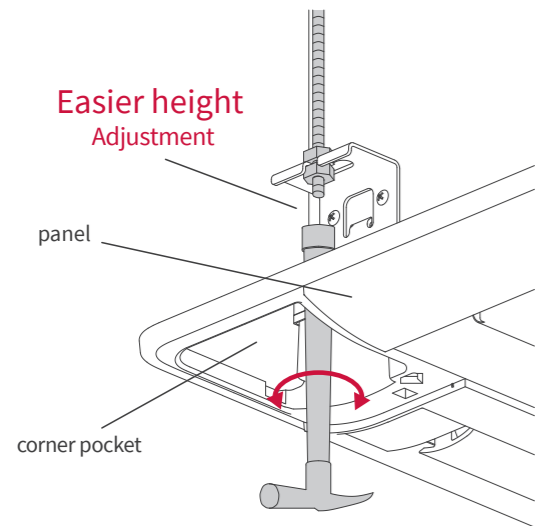

3) Suitable for high ceiling space

Standard drain-pump with 850mm lift

* Air flow rate: Hi2

* 2.0-6.0 FSR

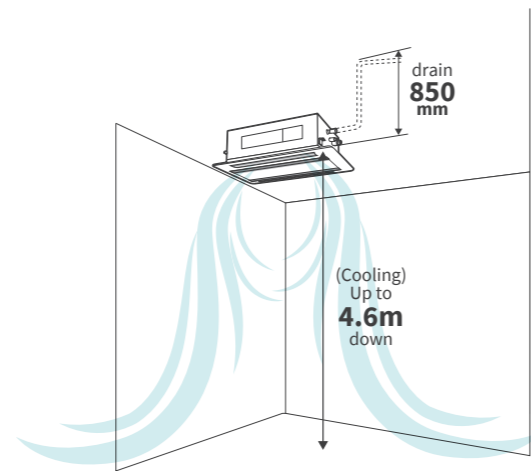

1-WAY CASSETTE TYPE

(DC MOTOR TYPE) [RCS-FSR]

FEATURES AND BENEFITS

1) 3 installation types selectable

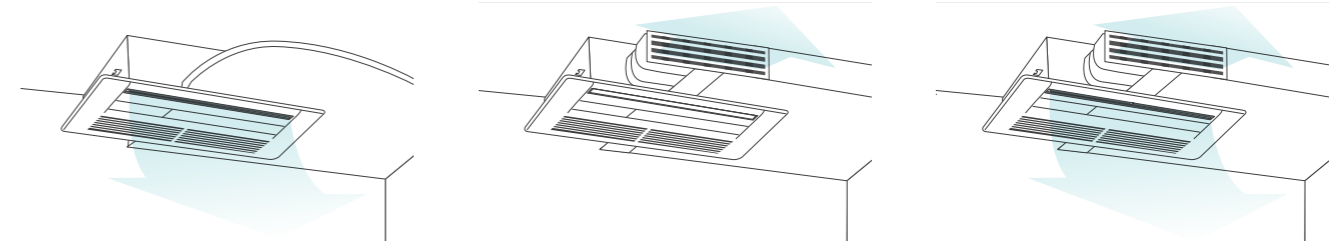

Corner type (standard)

Allows for ceiling planning for lighting and interiors, suitable for installation in the perimeter zone near the window

Clipped ceiling (one-way) type

Suitable for design that focuses on lighting and clipped ceilings, in case the unit is unable to be directly embedded in the ceiling

Clipped ceiling (two-way) type

Provides increased comfort through two-direction airflow by utilizing the advantages of installation on a clipped ceiling. Room temperature distribution can be improved by both forward airflow and downward airflow

2) Quiet operation

New design in fan inlet and fan resulted in the low sound pressure



IDU cooling capacity (kW)	2.2	2.8	4.0	5.6	7.1	8.0
Sound Pressure Level (dB(A))	27	28	31	31	32	33

* Air flow rate: Lo



3) Suitable for high ceiling space

Standard drain-pump with 850mm lift

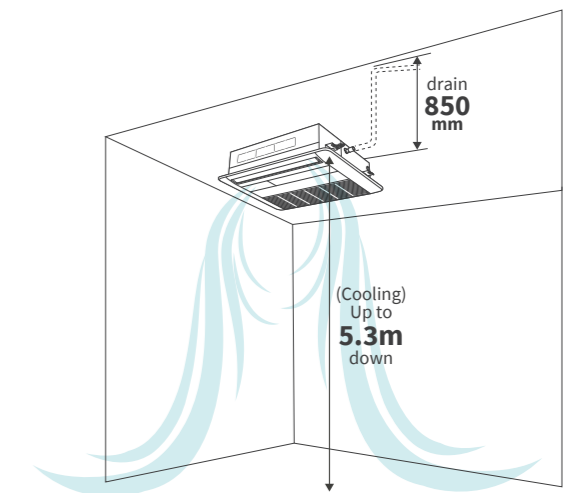

* Air flow rate: Hi2

* 2.5-3.0 FSR

* standard corner type

CONCEALED & EXPOSED

KEY INFORMATION

FEATURES TO SUIT YOUR PROJECT SPACE

The new SET FREE Σ range offers our widest choice of indoor units to give you the versatility to complement any interior.



WALL MOUNTED TYPE (DC MOTOR TYPE) [RPK-FSRM]

- Simple installation procedure
- Flexible discreet design suitable for any interior
- Setback temperature control available, leading to better operation.
- GentleCool control to ensure you are not bothered by cold draft



WALL MOUNTED TYPE (DC MOTOR TYPE) [RPK-HNBUSQ]

- Economic choice for any type of room
- Display set-temperature and operation status on front cover by LED



FLOOR/CEILING CONVERTIBLE TYPE (AC MOTOR TYPE) [RPF-C-FSNQ]

- Each unit can be floor mounted or ceiling suspended
- Easy installation
- Fresh air-intake design



CEILING SUSPENDED TYPE (DC MOTOR TYPE) [RPC-FSR]

- Ideal for a higher ceiling (up to 5.6m in cooling)
- Better power-saving with optional Motion Sensor
- Quiet operation level (as low as 28dB(A))
- Setback temperature control available, leading to better operation.
- GentleCool control to ensure you are not bothered by cold draft
- ViroSense S filter as standard!



FLOOR CONCEALED TYPE (AC MOTOR TYPE) [RPF-I-FSNQ]

- When there is no ceiling void, this unit gives you a minimal, low visibility option as it can be installed in floor cavities and walls
- Little installation space required, with only 202/220mm depth
- Suitable for installation under a window, with a 620mm height

COMPARISON

IDU Category	Cooling (kW)	2.2	2.8	3.6	4.0	4.3	5.0	5.6	6.3	7.1	8.0	8.4	9.0	11.2	14.0	14.2	16.0
WALL MOUNTED TYPE (DC MOTOR TYPE) [RPK-FSRM]										●	●				●		
WALL MOUNTED TYPE (DC MOTOR TYPE) [RPK-HNBUSQ]		●	●	●	●		●	●	●	●							
FLOOR / CEILING CONVERTIBLE TYPE (AC MOTOR TYPE) [RPF-C-FSNQ]							●	●	●	●		●	●	●		●	
CEILING SUSPENDED TYPE (DC MOTOR TYPE) [RPC-FSR]					●			●		●	●			●	●		●
FLOOR CONCEALED TYPE (AC MOTOR TYPE) [RPF-I-FSNQ]		●				●		●		●							

CONCEALED & EXPOSED

FEATURES COMPARISON

Model	WALL MOUNTED TYPE	FLOOR/CEILING CONVERTIBLE TYPE	CEILING SUSPENDED TYPE	FLOOR CONCEALED TYPE	
Model	RPK-FSRM	RPK-HNBUSQ	RPF-C-FSNQ	RPC-FSR	RPF-I-FSNQ
Temperature Setting Rate	0.5°C/1.0°C	1.0°C	1.0°C	0.5°C/1.0°C	1.0°C
Indoor Fan Speed	4 taps	6 taps	3 taps	4 taps	3 taps
Louver Direction	7 (*3)	7 (*3)	7 (*3)	7 (*3)	-
Individual Louver Setting	-	-	-	-	-
Auto Louver Setting	-	●	-	-	-
Dry mode Availability	●	●	●	●	●
Setback (Away Function)	●	-	-	●	-
Cold Draft Prevention Availability (*1) (*4)	●	-	●	●	●
Comfort setting Control Cool Air (GentleCool) (*2)	●	-	-	●	-
Direct/Indirect louver direction in COOL	-	-	-	-	-
Direct/Indirect louver direction in HEAT	-	-	-	-	-
FeetWarm air flow control	-	-	-	-	-
FloorSense Cool air flow control	-	-	-	-	-
Power Saving with Motion Sensor (*2)	-	-	-	●	-
Outdoor Unit capacity control (*2)	Peak cut control	●	-	-	●
	moderate control	●	-	-	●
Indoor Unit Rotation Control (*2)	Indoor Unit Address	●	-	-	●
	Indoor Air Temperature difference	●	-	-	●
Automatic Fan Operation	●	●	●	●	●
Quick Function (*2)	●	-	-	●	-
Daylight Saving Time	●	●	●	●	●
Power Consumption visualization (*2)	●	-	-	●	-
Weekly Schedule Setting	●	●	●	●	●
Power-Saving Setting (*2)	●	-	-	●	-
Dirty Filter Notice Availability	●	●	●	●	●
Check Menu	Sensor Condition Check	●	●	●	●
	Model Display (*2)	-	-	-	●
	Indoor/Outdoor PCB Check	●	●	●	●
	Alarm History Display	●	●	●	●
Motion Sensor	-	-	-	SOR-NEP	-
Receiver Kit for wireless remote controller	PC-ALHZ1	PC-RLH11 (*5) PC-ALHZ1	PC-RLH11 (*5) PC-ALHZ1	PC-ALHP1	PC-RLH11 (*5) PC-ALHZ1
Drain-up mechanism availability	-	-	-	DUPC-63K1 DUPC-71K1 DUPC-160K1	-
ViroSense S filter	-	-	-	●	-
Strainer kit	MSF-NP112A1	MSF-NP63A1	-	-	-

(*1) This function is utilized to prevent cold discharged air at start-up of heating operation, after defrosting operation, etc.

(*2) Advanced wired remote controller PC-ARF1 needs to be connected.

(*3) 5 steps only in the operation of Cooling or Dry.

(*4) Please consult your distributor for the availability.

(*5) Basic Receiver kit (PC-RLH11) is equipped with the unit in package as standard optional part with Wireless Remote Controller (PC-LH7QE).

CONCEALED & EXPOSED

WALL MOUNTED TYPE

(DC MOTOR TYPE) [RPK-FSRM]

FEATURES AND BENEFITS

- 1) Simple installation procedure
- 2) Flexible discreet design suitable for any interior
- 3) Hotel Setback feature available, leading to better operation
- 4) GentleCool control to ensure you are not bothered by cold draft



WALL MOUNTED TYPE

(DC MOTOR TYPE) [RPK-HNBUSQ]

FEATURES AND BENEFITS

- 1) Meet your detailed requirement & Display
DC fan motor help realize 6-step fan speed adjustment, more quiet and efficient. Also newly equipped display set-temperature and operation status on front cover by LED.
- 2) Simple installation procedure.
Refrigerant piping can be connected from the rear, base, or left of the unit, providing much greater flexibility for piping and selection of installation sites.
- 3) Flexible design suitable for any décor.
With smooth flat covers, the units match most modern interiors. Their compact size enables them to blend in, even in small spaces.
Compact cabinet design with 203mm depth up to 1.3HP and 230mm depth up to 2.5HP.
- 4) Easy maintenance.
Front flat panel keeps the unit from dust and facilitates maintenance work.
The front grille hinges open easily—no tools are needed to gain quick access to the filter.
The filter can be removed and cleaned as required.



CONCEALED & EXPOSED

FLOOR/CEILING CONVERTIBLE TYPE

(AC MOTOR TYPE) [RPFC-FSNQ]

FEATURES AND BENEFITS

1) Adapts to both floor and ceiling

[CEILING USE]

Supplies air to a wide area. High ceiling use capability.

[FLOOR USE]

Smaller footprint: Only 230mm in depth. Suitable for installation beneath a window thanks to the 680mm height.

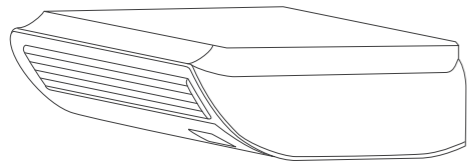

Ceiling Type

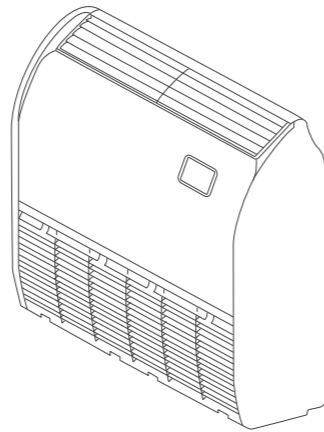

Floor Type

2) New air-intake design

Equipped with air-intakes, the unit connects with ventilations such as a Total Heat Exchanger using a duct, providing better interior air quality.



CEILING SUSPENDED TYPE

(DC MOTOR TYPE) [RPC-FSR]

FEATURES AND BENEFITS

1) Wide Detection area of motion sensor (SOR-NEP)

(Optional part) to achieve better energy-saving

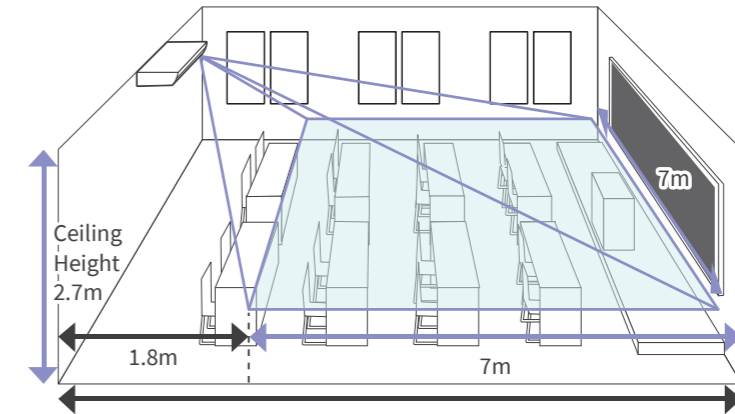

2) Auto louver

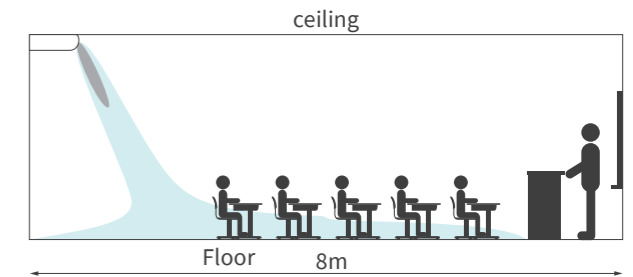
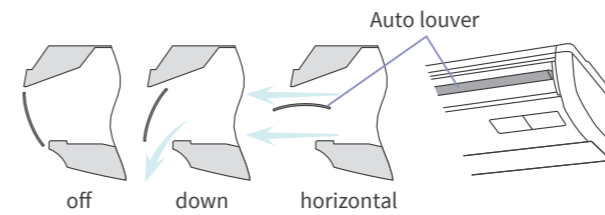

3) New design in fan inlet and fan resulted in the low sound pressure

Cooling capacity (kW)	4.0	8.0	11.2	14.0
Sound Pressure Level (dB(A))	28	29	32	35

* Air flow rate: Lo



4) Suitable for high ceiling space

IDU Capacity HP(Class)	1.5-3.0	4.0-6.0
Height (m)	3.5	4.3

* air flow volume: high

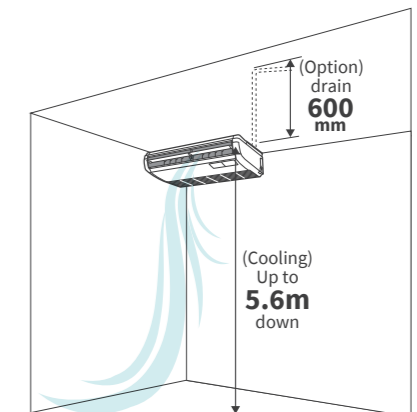

* Air flow rate: Hi2
* 4.0-6.0 FSR

CONCEALED & EXPOSED

FLOOR CONCEALED TYPE (AC MOTOR TYPE) [RPFI-FSNQ]

FEATURES AND BENEFITS

Blends unobtrusively with any interior décor: only the suction and discharge grilles are visible.

Its low height (only 620mm) enables the unit to fit perfectly beneath a window.

Requires little installation space thanks to its slim 202mm depth.

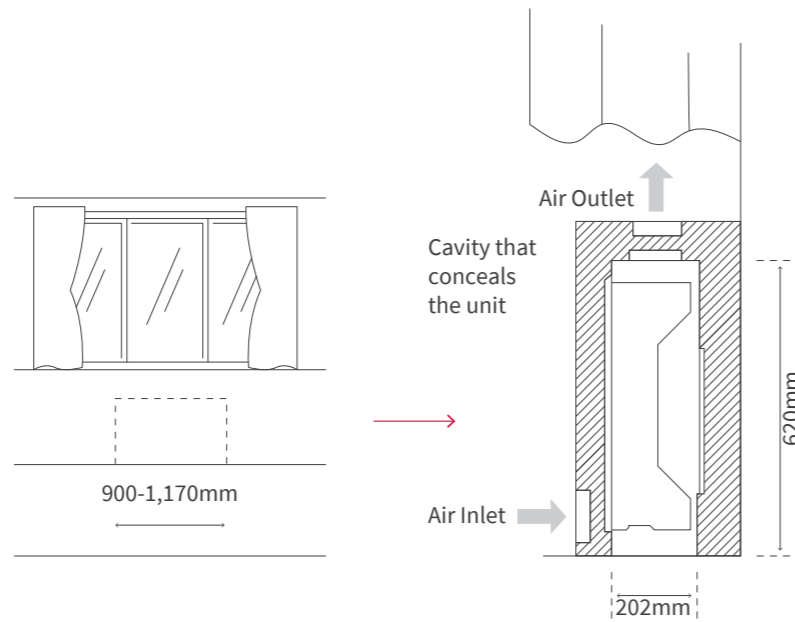

GENERAL DATA & ACCESSORIES

HIGH ESP TYPE (HIGH EXTERNAL STATIC PRESSURE TYPE) (AC MOTOR TYPE) [RPIH-HNAUNQ]



Model		RPIH-3.0HNAUNQ	RPIH-3.3HNAUNQ	RPIH-4.0HNAUNQ	RPIH-5.0HNAUNQ	RPIH-6.0HNAUNQ	
Indoor Unit Power Supply		AC 1Φ, [220-240V/50Hz]					
Nominal Capacity	Cooling	kW	8.4	9.0	11.2	14.2	16.0
	Heating	kW	9.6	10.0	13.0	16.3	18.0
Sound Pressure Level	(Hi/Me/Lo)	dB(A)	42/39/34	42/39/34	43/39/34	44/41/37	48/42/37
Outer Dimension	H×W×D	mm	300×1,175×800	300×1,175×800	300×1,175×800	300×1,475×800	300×1,475×800
Net Weight		kg	45	45	45	53	54
Refrigerant			R410A	R410A	R410A	R410A	R410A
Indoor Fan Air Flow Rate	(Hi/Me/Lo)	m ³ /min	30/28/23	30/28/23	30/28/23	35.5/32/27	41/33/26
External Static Pressure (*3)		Pa	120(90)	120(90)	120(90)	120(90)	120(90)
Connections		Flare-Nut Connection (with Flare Nuts)					
Refrigerant Piping Diameter	Liquid Line	mm	Φ9.52	Φ9.52	Φ9.52	Φ9.52	Φ9.52
	Gas Line	mm	Φ15.88	Φ15.88	Φ15.88	Φ15.88	Φ15.88
Condensate Drain			VP25	VP25	VP25	VP25	VP25
Approximate Packing Volume		m ³	0.40	0.40	0.40	0.49	0.49
Receiver Kit	Basic		PC-RLH11				
	Advanced		PC-ALHZ1				
Condensate Drain Pump Kit			DUPI-361Q				
	3.0-4.0 (HP class)		KW-PP9Q				
Air filter			KW-PP10Q				
	5.0-6.0 (HP class)		KW-PP10Q				
AQtiv-Ion Kit			JK-LZAQ				

NOTES:

1. The cooling capacities above show the maximum capacities when the outdoor and indoor temperature are under the following conditions.

Cooling Operation Conditions
Indoor Air Inlet Temperature: 27.0°C DB
19.0°C WB
Outdoor Air Inlet Temperature: 35.0°C DB

Heating Operation Conditions
Indoor Air Inlet Temperature: 20.0°C DB
7.0°C DB
Outdoor Air Inlet Temperature: 6.0°C WB

Piping Length: 7.5 metre
Piping Lift: 0 metre

2. The sound pressure level is based on following conditions. 1.4 metre Beneath the unit. With Discharge Duct (2.0 metre) and Return Duct (1.0 metre). Voltage of the power source for the indoor fan motor is 220V. (In case of the power source of 240V, the sound pressure level increases by about 1-2dB(A).) The above data was measured in an anechoic chamber so that reflected sound should be taken into consideration in the field.

3. The data for external pressure (*3) indicates *Standard Pressure Setting values when a filter is not used.

MEDIUM ESP TYPE (MEDIUM EXTERNAL STATIC PRESSURE TYPE) (AC MOTOR TYPE) [RPIM-HNAUNQ]



Model		RPIM-0.8HNAUNQ	RPIM-1.0HNAUNQ	RPIM-1.3HNAUNQ	RPIM-1.5HNAUNQ	RPIM-1.8HNAUNQ	RPIM-2.0HNAUNQ	RPIM-2.3HNAUNQ	RPIM-2.5HNAUNQ	
Indoor Unit Power Supply		AC 1Φ, [220-240V/50Hz]								
Nominal Capacity	Cooling	kW	2.2	2.8	3.6	4.3	5.0	5.6	6.3	7.1
	Heating	kW	2.8	3.3	4.2	4.9	5.6	6.5	7.5	8.5
Sound Pressure Level	(Hi/Me/Lo)	dB(A)	32/27/24	32/27/24	35/33/28	35/33/28	35.5/33/28	35.5/33/28	39/34/26	39/34/26
Outer Dimension	(H×W×D)	mm	270×725 ×720	270×725 ×720	270×725 ×720	270×725 ×720	270×975 ×720	270×975 ×720	270×975 ×720	270×975 ×720
Net Weight		kg	24	24	25	25	31	31	32	32
Refrigerant			R410A	R410A	R410A	R410A	R410A	R410A	R410A	R410A
Indoor Fan Air Flow Rate	(Hi/Me/Lo)	m ³ /min	10/8/7	10/8/7	12/11/9	12/11/9	16/14/11.5	16/14/11.5	20/16/11	20/16/11
External Static Pressure (*3)		Pa	50(80)	50(80)	50(80)	50(80)	50(80)	50(80)	50(80)	50(80)
Connections		Flare-Nut Connection (with Flare Nuts)								
Refrigerant Piping Diameter	Liquid Line	mm	Φ6.35	Φ6.35	Φ6.35	Φ6.35	Φ6.35	Φ6.35	Φ9.52	Φ9.52
	Gas Line	mm	Φ12.7	Φ12.7	Φ12.7	Φ12.7	Φ15.88	Φ15.88	Φ15.88	Φ15.88
Condensate Drain			VP25	VP25	VP25	VP25	VP25	VP25	VP25	VP25
Approximate Packing Volume		m ³	0.22	0.22	0.22	0.22	0.28	0.28	0.28	0.28
Receiver Kit	Basic		PC-RLH11							
	Advanced		PC-ALHZ1							
Condensate Drain Pump Kit			DUPI-131Q							
	0.8-2.5 (HP class)		DUPI-131Q							
Air filter			KW-PP7Q							
	1.8-2.5 (HP class)		KW-PP8Q							
AQtiv-Ion Kit			JK-LZAQ							

NOTES:

1. The cooling capacities above show the maximum capacities when the outdoor and indoor temperature are under the following conditions.

Cooling Operation Conditions
Indoor Air Inlet Temperature: 27.0°C DB
19.0°C WB
Outdoor Air Inlet Temperature: 35.0°C DB

Heating Operation Conditions
Indoor Air Inlet Temperature: 20.0°C DB
7.0°C DB
Outdoor Air Inlet Temperature: 6.0°C WB

Piping Length: 7.5 metre
Piping Lift: 0 metre

2. The sound pressure level is based on following conditions. 1.4 metre Beneath the unit. With Discharge Duct (2.0 metre) and Return Duct (1.0 metre). Voltage of the power source for the indoor fan motor is 220V. (In case of the power source of 240V, the sound pressure level increases by about 1-2dB(A).) The above data was measured in an anechoic chamber so that reflected sound should be taken into consideration in the field.

3. The data for external pressure (*3) indicates *Standard Pressure Setting values when a filter is not used.

GENERAL DATA & ACCESSORIES



LOW ESP TYPE (LOW EXTERNAL STATIC PRESSURE TYPE) (AC MOTOR TYPE) [RPIL-HNAUNQ]

Model		RPIL-0.8HNAUNQ	RPIL-1.0HNAUNQ	RPIL-1.3HNAUNQ	RPIL-1.5HNAUNQ	RPIL-1.8HNAUNQ	RPIL-2.0HNAUNQ	RPIL-2.3HNAUNQ	
Indoor Unit Power Supply		AC 1Φ, [220-240V/50Hz]							
Nominal Capacity	Cooling	kW	2.2	2.8	3.6	4.3	5.0	5.6	6.3
	Heating	kW	2.8	3.3	4.2	4.9	5.6	6.5	7.5
Sound Pressure Level	(Hi/Me/Lo)	dB(A)	28/25/22	28/25/22	34/32/30	34/32/30	34/32/29	34/32/29	36.5/30.5/25
Outer Dimension	(H×W×D)	mm	270×725×720	270×725×720	270×725×720	270×725×720	270×975×720	270×975×720	
Net Weight		kg	24	24	25	25	31	31	32
Refrigerant			R410A	R410A	R410A	R410A	R410A	R410A	R410A
Indoor Fan Air Flow Rate	(Hi/Me/Lo)	m ³ /min	9/8/7	9/8/7	13/11/9	13/11/9	15/14/12	15/14/12	21/14/11
External Static Pressure (*3)		Pa	30	30	30	30	30	30	30
Connections			Flare-Nut Connection (with Flare Nuts)						
Refrigerant Piping Diameter	Liquid Line	mm	Φ6.35	Φ6.35	Φ6.35	Φ6.35	Φ6.35	Φ6.35	Φ9.52
	Gas Line	mm	Φ12.7	Φ12.7	Φ12.7	Φ12.7	Φ15.88	Φ15.88	Φ15.88
Condensate Drain			VP25	VP25	VP25	VP25	VP25	VP25	VP25
Approximate Packing Volume		m ³	0.22	0.22	0.22	0.22	0.28	0.28	0.28

Model		RPIL-2.5HNAUNQ	RPIL-3.0HNAUNQ	RPIL-3.3HNAUNQ	RPIL-4.0HNAUNQ	RPIL-5.0HNAUNQ	RPIL-6.0HNAUNQ	
Indoor Unit Power Supply		AC 1Φ, [220-240V/50Hz]						
Nominal Capacity	Cooling	kW	7.1	8.4	9.0	11.2	14.2	16.0
	Heating	kW	8.5	9.6	10.0	13.0	16.3	18.0
Sound Pressure Level	(Hi/Me/Lo)	dB(A)	36.5/30.5/25	38/30/24	38/30/24	38/35/31	44/39/35	46/41/35
Outer Dimension	(H×W×D)	mm	270×975×720	300×1,175×800	300×1,175×800	300×1,175×800	300×1,475×800	300×1,475×800
Net Weight		kg	32	45	45	45	53	54
Refrigerant			R410A	R410A	R410A	R410A	R410A	R410A
Indoor Fan Air Flow Rate	(Hi/Me/Lo)	m ³ /min	21/14/11	29/25/21	29/25/21	29/25/21	36/31/26	42/34/26
External Static Pressure (*3)		Pa	30	60	60	60	60	60
Connections			Flare-Nut Connection (with Flare Nuts)					
Refrigerant Piping Diameter	Liquid Line	mm	Φ9.52	Φ9.52	Φ9.52	Φ9.52	Φ9.52	Φ9.52
	Gas Line	mm	Φ15.88	Φ15.88	Φ15.88	Φ15.88	Φ15.88	Φ15.88
Condensate Drain			VP25	VP25	VP25	VP25	VP25	VP25
Approximate Packing Volume		m ³	0.28	0.40	0.40	0.40	0.49	0.49

Receiver Kit	Basic	PC-RLH11	Air filter	0.8-1.5 (HP class)	KW-PP7Q
	Advanced	PC-ALHZ1		1.8-2.5 (HP class)	KW-PP8Q
Condensate Drain Pump Kit	0.8-2.5 (HP class)	DUPI-131Q	3.0-4.0 (HP class)	KW-PP9Q	
	3.0-6.0 (HP class)	DUPI-361Q	5.0-6.0 (HP class)	KW-PP10Q	
AQtiv-Ion Kit				JK-LZAQ	

NOTE:
1. The cooling capacities above show the maximum capacities when the outdoor and indoor temperature are under the following conditions.
Cooling Operation Conditions
Indoor Air Inlet Temperature: 27.0°C DB
19.0°C WB
Outdoor Air Inlet Temperature: 35.0°C DB
Piping Length: 7.5 metre
Piping Lift: 0 metre

Heating Operation Conditions
Indoor Air Inlet Temperature: 20.0°C DB
Outdoor Air Inlet Temperature: 7.0°C DB
6.0°C WB

Piping Length: 7.5 metre
Piping Lift: 0 metre

2. The sound pressure level is based on following conditions. 1.4 metre Beneath the unit.
With Discharge Duct (2.0 metre) and Return Duct (1.0 metre).
Voltage of the power source for the indoor fan motor is 220V.
(In case of the power source of 240V, the sound pressure level increases by about 1~2dB(A).)
The above data was measured in an anechoic chamber so that reflected sound should be taken into consideration in the field.

3. The data for external pressure (*3) indicates "Standard Pressure Setting values when a filter is not used."



COMPACT TYPE (DC MOTOR TYPE) [RPIZ-HNDTSQ]

Model		RPIZ-0.8HNDTSQ	RPIZ-1.0HNDTSQ	RPIZ-1.3HNDTSQ	RPIZ-1.5HNDTSQ	RPIZ-1.8HNDTSQ	RPIZ-2.0HNDTSQ	RPIZ-2.3HNDTSQ	RPIZ-2.5HNDTSQ		
Indoor Unit Power Supply		AC 1Φ, [220-240V/50Hz] [220V/60Hz]									
Nominal Capacity	Cooling	kW	2.2	2.8	3.6	4.0	5.0	5.6	6.3	7.1	
	Heating	kW	2.5	3.2	4.0	4.5	5.6	6.3	7.1	8.0	
Sound Pressure Level	(6 taps)	dB(A)	33/31/28/25/23.5/22.5	33/31/28/25/23.5/22.5	33/31/28/25/23.5/22.5	31/30/28/25/22/20	36/33.5/31/28/24.5/22.5	36/33.5/31/28/24.5/22.5	37/36/33/30/28/25	37/36/33/30/28/25	
Outer Dimension	H×W×D	mm	192×700×447	192×700×447	192×700×447	192×910×447	192×1,180×447	192×1,180×447	192×1,180×447	192×1,180×447	
Net Weight		kg	17	17	17	20	24	24	24	24	
Refrigerant			R410A	R410A	R410A	R410A	R410A	R410A	R410A	R410A	
Indoor Fan Air Flow Rate	(6 taps)	m ³ /min	8.5/8/7/6/5.5/5	8.5/8/7/6/5.5/5	8.5/8/7/6/5.5/5	10/9/8/7.5/6.5/6	14.5/13.2/11.8/10.5/9.2/8.0	14.5/13.2/11.8/10.5/9.2/8.0	16.5/15/13/12/10/9	16.5/15/13/12/10/9	
External Static Pressure (*3)		Pa	10(0-10-30)	10(0-10-30)	10(0-10-30)	10(0-10-30)	10(0-10-50)	10(0-10-50)	10(0-10-50)	10(0-10-50)	
Connections			Flare-Nut Connection (with Flare Nuts)								
Refrigerant Piping Diameter	Liquid Line	mm	Φ6.35	Φ6.35	Φ6.35	Φ6.35	Φ6.35	Φ6.35	Φ9.52	Φ9.52	
	Gas Line	mm	Φ12.70	Φ12.70	Φ12.70	Φ12.70	Φ15.88	Φ15.88	Φ15.88	Φ15.88	
Condensate Drain			VP25	VP25	VP25	VP25	VP25	VP25	VP25	VP25	
Approximate Packing Volume		m ³	0.142	0.142	0.142	0.15	0.18	0.18	0.18	0.18	

Receiver Kit	Basic	PC-RLH11
	Advanced	PC-ALHZ1
Condensate Drain Pump Kit		- (included as standard equipment)
Air filter	0.8-1.3 (HP Class)	KW-PP12Q
	1.5 (HP Class)	KW-PP5Q
	1.8-2.5 (HP Class)	KW-PP6Q
AQtiv-Ion Kit		JK-LZAQ

NOTES:

1. The cooling capacities above show the maximum capacities when the outdoor and indoor temperature are under the following conditions.

Cooling Operation Conditions Indoor Air Inlet Temperature: 27.0°C DB 19.0°C WB Outdoor Air Inlet Temperature: 35.0°C DB Piping Length: 7.5 metre Piping Lift: 0 metre	Heating Operation Conditions Indoor Air Inlet Temperature: 20.0°C DB Outdoor Air Inlet Temperature: 7.0°C DB 6.0°C WB
--	--

2. The sound pressure level is based on following conditions. 1.4 metre Beneath the unit.
With Discharge Duct (2.0 metre) and Return Duct (1.0 metre).
Voltage of the power source for the indoor fan motor is 220V.

(In case of the power source of 240V, the sound pressure level increases by about 1~2dB(A).)
The above data was measured in an anechoic chamber so that reflected sound should be taken into consideration in the field.

3. The data for external pressure (*3) indicates "Standard Pressure Setting values when a filter is not used."

4. When the model of RAS-7.0-12HNBMRQ outdoor unit is connected to the compact ducted type indoor units (RPIZ), if only one indoor unit is in cooling operation, and the capacity is less than 2.8kW, the minimum outdoor temperature is 5.0°C DB.

COMPACT TYPE (AC MOTOR TYPE) [RPIZ-HNATNQ]

Model		RPIZ-0.8HNATNQ	RPIZ-1.0HNATNQ	RPIZ-1.3HNATNQ	RPIZ-1.5HNATNQ	RPIZ-1.8HNATNQ	RPIZ-2.0HNATNQ	RPIZ-2.3HNATNQ	RPIZ-2.5HNATNQ		
Indoor Unit Power Supply		AC 1Φ, [220-240V/50Hz]									
Nominal Capacity	Cooling	kW	2.2	2.8	3.6	4.0	5.0	5.6	6.3	7.1	
	Heating	kW	2.5	3.2	4.0	4.5	5.6	6.3	7.1	8.0	
Sound Pressure Level	(Hi/Me/Lo)	dB(A)	30/23/20	30/23/20	34/25/22	32.5/26/23	34/26/25	34/26/25	37/29/27	37/29/27	
Outer Dimension	H×W×D	mm	192×700×447	192×700×447	192×700×447	192×910×447	192×1,180×447	192×1,180×447	192×1,180×447	192×1,180×447	
Net Weight		kg	17	17	17	21	27	28	28	28	
Refrigerant			R410A	R410A	R410A	R410A	R410A	R410A	R410A	R410A	
Indoor Fan Air Flow Rate	(Hi/Me/Lo)	m ³ /min	9.5/6.5/5.5	9.5/6.5/5.5	9.5/6.5/5.5	10/7/6	15/10/9	15/10/9	17/10/9	17/10/9	
External Static Pressure (*3)		Pa	10(30)	10(30)	10(30)	10(30)	10(30)	10(30)	10(30)	10(30)	
Connections			Flare-Nut Connection (with Flare Nuts)								
Refrigerant Piping Diameter	Liquid Line	mm	Φ6.35	Φ6.35	Φ6.35	Φ6.35	Φ6.35	Φ6.35	Φ9.52	Φ9.52	
	Gas Line	mm	Φ12.70	Φ12.70	Φ12.70	Φ12.70	Φ15.88	Φ15.88	Φ15.88	Φ15.88	
Condensate Drain			VP25	VP25	VP25	VP25	VP25	VP25	VP25	VP25	
Approximate Packing Volume		m ³	0.142	0.142	0.142	0.15	0.18	0.18	0.18	0.18	

Receiver Kit	Basic	PC-RLH11
	Advanced	PC-ALHZ1
Condensate Drain Pump Kit		- (included as standard equipment)
Air filter	0.8-1.3 (HP Class)	KW-PP12Q
	1.5 (HP Class)	KW-PP5Q
	1.8-2.5 (HP Class)	KW-PP6Q
AQtiv-Ion Kit		JK-LZAQ

NOTES:

1. The cooling capacities above show the maximum capacities when the outdoor and indoor temperature are under the following conditions.

Cooling Operation Conditions Indoor Air Inlet Temperature: 27.0°C DB 19.0°C WB Outdoor Air Inlet Temperature: 35.0°C DB Piping Length: 7.5 metre Piping Lift: 0 metre	Heating Operation Conditions Indoor Air Inlet Temperature: 20.0°C DB Outdoor Air Inlet Temperature: 7.0°C DB 6.0°C WB
--	--

2. The sound pressure level is based on following conditions. 1.4 metre Beneath the unit.
With Discharge Duct (2.0 metre) and Return Duct (1.0 metre).
Voltage of the power source for the indoor fan motor is 220V.

(In case of the power source of 240V, the sound pressure level increases by about 1~2dB(A).)
The above data was measured in an anechoic chamber so that reflected sound should be taken into consideration in the field.

3. The data for external pressure (*3) indicates "Standard Pressure Setting values when a filter is not used."

4. When the model of RAS-7.0-12HNBMRQ outdoor unit is connected to the compact ducted type indoor units (RPIZ), if only one indoor unit is in cooling operation, and the capacity is less than 2.8kW, the minimum outdoor temperature is 5.0°C DB.

GENERAL DATA & ACCESSORIES

4-WAY CASSETTE TYPE (DC MOTOR TYPE) [RCI-FSRP]

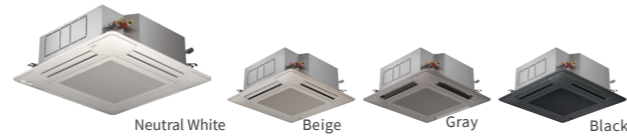

Model			RCI-1.0FSRP	RCI-1.5FSRP	RCI-2.0FSRP	RCI-2.5FSRP	RCI-3.0FSRP	RCI-4.0FSRP	RCI-5.0FSRP	RCI-6.0FSRP
Indoor Unit Power Supply			AC 1Φ, [220-240V/50Hz] [220V/60Hz]							
Nominal Capacity	Cooling	kW	2.8	4.0	5.6	7.1	8.0	11.2	14.0	16.0
	Heating	kW	3.2	4.8	6.3	8.5	9.0	12.5	16.0	18.0
Sound Pressure Level	(Hi2/Hi/Me/Lo)	dB(A)	33/30/28/27	35/31/30/27	37/32/30/27	42/36/32/28	42/36/32/28	48/43/39/33	48/45/40/35	48/46/41/37
			Outer Dimension (H×W×D)	mm	248×840×840	248×840×840	248×840×840	248×840×840	298×840×840	298×840×840
Net Weight		kg	20	21	21	22	26	26	26	26
Refrigerant			R410A							
Indoor Fan Air Flow Rate	(Hi2/Hi/Me/Lo)	m ³ /min	15/13/11/9	21/17/14/11	22/17/14/11	27/23/18/14	27/23/18/14	37/31/24/20	37/33/26/21	37/35/28/22
			Connections			Flare-Nut Connection (with flare Nuts)				
Refrigerant	Liquid Line	mm	Φ6.35	Φ6.35	Φ6.35	Φ9.52	Φ9.52	Φ9.52	Φ9.52	Φ9.52
	Gas Line	mm	Φ12.7	Φ12.7	Φ15.88	Φ15.88	Φ15.88	Φ15.88	Φ15.88	Φ15.88
Condensate Drain			VP25							
Approximate Packing Volume			m ³							

Decoration panel	Twin-Sense panel	P-AP160NAE2	T-Pipe Connection Kit	TKCI-160K	
	Standard (without sensor)	P-AP160NA3		1.0-2.5 (HP Class)	F-71L-D1
Receiver kit	Advanced	PC-ALH3	Normal Air Filter	3.0-6.0 (HP Class)	F-160L-D1
	Condensate Drain Pump Kit			Filter Box	B-160H3
Duct Adapter			ViroSense Z2 filter	F-160L-ZV	
Fresh Air Intake Kit			ViroSense S filter	-(Standard)	
3-Way Outlet Parts Set			PI-160LS2		

NOTES:

- The cooling and heating capacities above show the maximum capacities when the outdoor and indoor temperature are under the following conditions.

Cooling Operation Conditions		Heating Operation Conditions	
Indoor Air Inlet Temperature:	27.0°C DB 19.0°C WB	Indoor Air Inlet Temperature:	20.0°C DB 7.0°C DB
Outdoor Air Inlet Temperature:	35.0°C DB	Outdoor Air Inlet Temperature:	6.0°C WB
Piping Length: 7.5 metre		Piping Length: 7.5 metre	
Piping Lift: 0 metre		Piping Lift: 0 metre	
- The sound pressure level is based on following conditions. 1.5 metre Beneath the unit.
The data in the table above was measured in an anechoic chamber so that reflected sound should be taken into consideration in the field.

4-WAY CASSETTE TYPE (DC MOTOR TYPE) [RCI-FSKDNQ]



Model			RCI-1.0FSKDNQ	RCI-1.5FSKDNQ	RCI-2.0FSKDNQ	RCI-2.5FSKDNQ	RCI-3.0FSKDNQ	RCI-4.0FSKDNQ	RCI-5.0FSKDNQ	RCI-6.0FSKDNQ
Indoor Unit Power Supply			AC 1Φ, [220-240V/50Hz] [220V/60Hz]							
Nominal Capacity	Cooling	kW	2.8	4.0	5.6	7.1	8.0	11.2	14.0	16.0
	Heating	kW	3.2	4.8	6.3	8.5	9.0	12.5	16.0	18.0
Sound Pressure Level	(Hi2/Hi/Me/Lo)	dB(A)	33/30/28/27	35/31/30/27	37/32/30/27	42/36/32/28	42/36/32/28	48/43/39/33	48/45/40/35	48/46/41/37
			Outer Dimension (H×W×D)	mm	238×840×840	238×840×840	238×840×840	238×840×840	288×840×840	288×840×840
Net Weight		kg	20	21	21	22	26	26	26	26
Refrigerant			R410A							
Indoor Fan Air Flow Rate	(Hi2/Hi/Me/Lo)	m ³ /min	15/13/11/9	21/17/14/11	22/17/14/11	27/23/18/14	27/23/18/14	37/31/24/20	37/33/26/21	37/35/28/22
			Connections			Flare-Nut Connection (with flare Nuts)				
Refrigerant	Liquid Line	mm	Φ6.35	Φ6.35	Φ6.35	Φ9.52	Φ9.52	Φ9.52	Φ9.52	Φ9.52
	Gas Line	mm	Φ12.7	Φ12.7	Φ12.7	Φ15.88	Φ15.88	Φ15.88	Φ15.88	Φ15.88
Condensate Drain			VP25							
Approximate Packing Volume			m ³							

Decoration Panel			-(Standard)							
Receiver Kit	Basic	HR4A10NEWQ	Condensate Drain Pump Kit			-(Standard)				
	Advanced	PC-ALH3	Duct Adapter			PD-75A				
			ViroSense Z2 filter			F-160L-ZV				

NOTE:

- The cooling and heating capacities above show the maximum capacities when the outdoor and indoor temperature are under the following conditions.

Cooling Operation Conditions		Heating Operation Conditions	
Indoor Air Inlet Temperature:	27.0°C DB (80.0°F DB) 19.0°C WB (66.2°F WB)	Indoor Air Inlet Temperature:	20.0°C DB (68.0°F DB) 7.0°C DB (45.0°F DB)
Outdoor Air Inlet Temperature:	35.0°C DB (95.0°F DB)	Outdoor Air Inlet Temperature:	6.0°C WB (43.0°F WB)
Piping Length: 7.5 metre		Piping Length: 7.5 metre	
Piping Lift: 0 metre		Piping Lift: 0 metre	
- The sound pressure level is based on following conditions. 1.5 metre Beneath the unit.
The data in the table above was measured in an anechoic chamber so that reflected sound should be taken into consideration in the field.
- Decoration panel is included.

Silent-Iconic™ for 4-WAY CASSETTE (RCI-FSRP)



Model	P-GP160NAP	P-GP160NAPU	P-GP160KAP
satandard/option	Design Panel Standard	Design Panel with an Elevation Grille	Design Panel Standard
color	Natural White	Natural White	Black



4-WAY CASSETTE COMPACT TYPE (DC MOTOR TYPE) [RCIM-FSRE]



Model			RCIM-0.8FSRE	RCIM-1.0FSRE	RCIM-1.5FSRE	RCIM-2.0FSRE	RCIM-2.5FSRE
Indoor Unit Power Supply			AC 1Φ, [230V/50Hz] [220-240V/50Hz] [220V/60Hz]				
Nominal Capacity	Cooling	kW	2.2	2.8	4.0	5.6	7.1
	Heating	kW	2.5	3.2	4.8	6.3	8.5
Sound Pressure Level	(Hi2/Hi/Me/Lo)	dB(A)	36/33/29/24.5	38/34/30/24.5	41/37/33/27.5	45/39/35/31	47/43/39/35
			Outer Dimension (H×W×D)	mm	285×570×570	285×570×570	285×570×570
Net Weight		kg	16	16	16	17	17
Refrigerant			R410A				
Indoor Fan Air Flow Rate	(Hi2/Hi/Me/Lo)	m ³ /min	11/9.5/8/6	12/10/8.5/6	13/11/9.5/7	15/12/10/8	16/14/12/10
			Connections			Flare-Nut Connection (with Flare Nuts)	
Refrigerant	Liquid Line	mm	Φ6.35	Φ6.35	Φ6.35	Φ6.35	Φ9.52
	Gas Line	mm	Φ12.7	Φ12.7	Φ12.7	Φ12.7	Φ15.88
Condensate Drain			VP25				
Approximate Packing Volume			m ³				

Decoration panel			P-AP56NAM				Motion Sensor		SOR-NEC	
Decoration panel with Receiver kit	Advanced	P-AP56NAMR	Condensate Drain Pump Kit			-(Standard)				
	Advanced	PC-ALHC1	Duct Adapter			PD-75C				

NOTES:

- The cooling and heating capacities above show the maximum capacities when the outdoor and indoor temperature are under the following conditions.

Cooling Operation Conditions		Heating Operation Conditions	
Indoor Air Inlet Temperature:	27.0°C DB 19.0°C WB	Indoor Air Inlet Temperature:	20.0°C DB 7.0°C DB
Outdoor Air Inlet Temperature:	35.0°C DB	Outdoor Air Inlet Temperature:	6.0°C WB
Piping Length: 7.5 metre		Piping Length: 7.5 metre	
Piping Lift: 0 metre		Piping Lift: 0 metre	
- The sound pressure level is based on following conditions. 1.5 metre Beneath the unit.
The data in the table above was measured in an anechoic chamber so that reflected sound should be taken into consideration in the field.

GENERAL DATA & ACCESSORIES

2-WAY CASSETTE TYPE

(DC MOTOR TYPE) [RCD-FSR]



Model	RCD-0.8FSR	RCD-1.0FSR	RCD-1.5FSR	RCD-2.0FSR	RCD-2.5FSR	RCD-3.0FSR	RCD-4.0FSR	RCD-5.0FSR	RCD-6.0FSR		
Indoor Unit Power Supply	AC 1Φ, [220-240V/50Hz] [220V/60Hz]										
Nominal Capacity	Cooling	kW	2.2	2.8	4.0	5.6	7.1	8.0	11.2	14.0	16.0
	Heating	kW	2.5	3.2	4.8	6.3	8.5	9.0	12.5	16.0	18.0
Sound Pressure Level	(Hi2/Hi/Me/Lo)	dB(A)	30/29/28/27	31/29/28/27	37/34/31/30	39/36/33/30	42/39/36/33	45/42/38/33	43/40/37/34	47/44/41/35	48/45/42/39
Outer Dimension	(H×W×D)	mm	298×860×630	298×860×630	298×860×630	298×860×630	298×860×630	298×1,420×630	298×1,420×630	298×1,420×630	
Net Weight		kg	23	23	25	25	25	39	39	39	
Refrigerant			R410A	R410A	R410A	R410A	R410A	R410A	R410A	R410A	
Indoor Fan Air Flow Rate	(Hi2/Hi/Me/Lo)	m³/min	10/9/7.5/6.5	11/9.5/8.5/7	15/13/11.5/10	16.5/14.5/12.5/10.5	18.5/16.5/14.5/12.5	21/18.5/16/12.5	30/26.5/23/20	35/31/27/21	37/32.5/28.5/24
Connections	Flare-Nut Connection (with Flare Nuts)										
Refrigerant	Liquid Line	mm	Φ6.35	Φ6.35	Φ6.35	Φ6.35	Φ9.52	Φ9.52	Φ9.52	Φ9.52	Φ9.52
Piping Diameter	Gas Line	mm	Φ12.7	Φ12.7	Φ12.7	Φ12.7	Φ15.88	Φ15.88	Φ15.88	Φ15.88	Φ15.88
Condensate Drain			VP25	VP25	VP25	VP25	VP25	VP25	VP25	VP25	VP25
Approximate Packing Volume		m³	0.24	0.24	0.24	0.24	0.24	0.24	0.36	0.36	0.36

Decoration panel	0.8-3.0 (HP Class)	P-AP90DNA	Antibacterial Long-life Filter	0.8-3.0 (HP Class)	F-90MD-K1
	4.0-6.0 (HP Class)	P-AP160DNA		4.0-6.0 (HP Class)	F-160MD-K1
Receiver kit	Advanced	PC-ALHD1	Filter Box	0.8-3.0 (HP Class)	B-90HD
Motion Sensor		SOR-NED		4.0-6.0 (HP Class)	B-160HD
Condensate Drain Pump Kit		-(Standard)	ViroSense S filter		-(Standard)
Duct Adapter		PD-150D			

NOTES:

1. The cooling and heating capacities above show the maximum capacities when the outdoor and indoor temperature are under the following conditions.

Cooling Operation Conditions		Heating Operation Conditions	
Indoor Air Inlet Temperature:	27.0°C DB	Indoor Air Inlet Temperature:	20.0°C DB
	19.0°C WB	Outdoor Air Inlet Temperature:	7.0°C DB
Outdoor Air Inlet Temperature:	35.0°C DB		6.0°C WB
Piping Length: 7.5 metre		Piping Length: 7.5 metre	
Piping Lift: 0 metre		Piping Lift: 0 metre	

2. The sound pressure level is based on following conditions. 1.5 metre Beneath the unit.

The data in the table above was measured in an anechoic chamber so that reflected sound should be taken into consideration in the field.

1-WAY CASSETTE TYPE

(DC MOTOR TYPE) [RCS-FSR]



Model	RCS-0.8FSR	RCS-1.0FSR	RCS-1.5FSR	RCS-2.0FSR	RCS-2.5FSR	RCS-3.0FSR		
Indoor Unit Power Supply	AC 1Φ, [220-240V/50Hz] [230V/50Hz] [220V/60Hz]							
Nominal Capacity	Cooling	kW	2.2	2.8	4.0	5.6	7.1	8.0
	Heating	kW	2.5	3.2	4.8	6.3	8.5	9.0
Sound Pressure Level	(Hi2/Hi/Me/Lo)	dB(A)	34/32/29/27	36/34/31/28	40/37/33/31	42/38/35/31	43/39/36/32	43/40/37/33
Outer Dimension	(H×W×D)	mm	235×900×710	235×900×710	235×900×710	235×900×710	235×1,210×710	235×1,210×710
Net Weight		kg	25	25	26	26	33	33
Refrigerant			R410A	R410A	R410A	R410A	R410A	R410A
Indoor Fan Air Flow Rate	(Hi2/Hi/Me/Lo)	m³/min	8.5/7.5/6.5/6	9.5/8.5/7.5/6.5	13/11.5/10/8.5	14.5/13/11/9.5	18.5/16.5/14.5/12.5	20/17.5/15.5/13
Connections	Flare-Nut Connection (with Flare Nuts)							
Refrigerant	Liquid Line	mm	Φ6.35	Φ6.35	Φ6.35	Φ6.35	Φ9.52	Φ9.52
Piping Diameter	Gas Line	mm	Φ12.7	Φ12.7	Φ12.7	Φ12.7	Φ15.88	Φ15.88
Condensate Drain			VP25	VP25	VP25	VP25	VP25	VP25
Approximate Packing Volume		m³	0.25	0.25	0.25	0.25	0.32	0.32

Decoration panel	0.8-1.0 (HP Class)	P-AP36CNA	Duct Adapter		PD-100	
	1.5-2.0 (HP Class)	P-AP56CNA		Drille for Front Discharge	0.8-2.0 (HP Class)	DG-56SW1
	2.5-3.0 (HP Class)	P-AP80CNA			2.5-3.0 (HP Class)	DG-80SW1
Receiver kit	Advanced	PC-ALHS1	Air Outlet Shutter Plate	0.8-2.0 (HP Class)	PIS-56LS	
Motion Sensor		SOR-NES			2.5-3.0 (HP Class)	PIS-80LS
Condensate Drain Pump Kit		-(Standard)	ViroSense S filter		-(Standard)	

NOTES:

1. The cooling and heating capacities above show the maximum capacities when the outdoor and indoor temperature are under the following conditions.

Cooling Operation Conditions		Heating Operation Conditions	
Indoor Air Inlet Temperature:	27.0°C DB	Indoor Air Inlet Temperature:	20.0°C DB
	19.0°C WB	Outdoor Air Inlet Temperature:	7.0°C DB
Outdoor Air Inlet Temperature:	35.0°C DB		6.0°C WB
Piping Length: 7.5 metre		Piping Length: 7.5 metre	
Piping Lift: 0 metre		Piping Lift: 0 metre	

2. The sound pressure level is based on following conditions. 1.5 metre Beneath the unit.

The data in the table above was measured in an anechoic chamber so that reflected sound should be taken into consideration in the field.

WALL MOUNTED TYPE

(DC MOTOR TYPE) [RPK-FSRM]



Type	Expansion Valve built-in type				
Model	RPK-2.5FSRM	RPK-3.0FSRM	RPK-4.0FSRM		
Indoor Unit Power Supply	AC 1Φ, [220-240V/50Hz] [220V/60Hz]				
Nominal Capacity	Cooling	kW	7.1	8.0	11.2
	Heating	kW	8.5	9.0	12.5
Sound Pressure Level	(Hi2/Hi/Me/Lo)	dB(A)	45/42/38/35	47/44/40/35	51/48/44/39
Color	White				
Outer Dimension	(H×W×D)	mm	300×1,100×260	300×1,100×260	300×1,100×260
Net Weight		kg	15	15	15
Refrigerant			R410A	R410A	R410A
Indoor Fan Air Flow Rate	(Hi2/Hi/Me/Lo)	m³/min	18.5/16.5/14/12	20/17.5/15.5/12.5	23/20/17.5/14.5
Motor			38	38	38
Connections	Flare-Nut Connection (with Flare Nuts)				
Refrigerant Piping Diameter	Liquid Line	mm	Φ9.52	Φ9.52	Φ9.52
	Gas Line	mm	Φ15.88	Φ15.88	Φ15.88
Condensate Drain			VP16	VP16	VP16
Approximate Packing Volume		m³	0.14	0.14	0.14
Accessory included	Wall Mounting Bracket				

Receiver kit	Advanced	PC-ALHZ1
Strainer kit	2.5-4.0 (HP Class)	MSF-NP112A1

NOTES:

1. The cooling and heating capacities above show the maximum capacities when the outdoor and indoor temperature are under the following conditions.

Cooling Operation Conditions		Heating Operation Conditions	
Indoor Air Inlet Temperature:	27.0°C DB	Indoor Air Inlet Temperature:	20.0°C DB
	19.0°C WB	Outdoor Air Inlet Temperature:	7.0°C DB
Outdoor Air Inlet Temperature:	35.0°C DB		6.0°C WB
Piping Length: 7.5 metre		Piping Length: 7.5 metre	
Piping Lift: 0 metre		Piping Lift: 0 metre	

2. The sound pressure level is based on following conditions.

1.0 metre Beneath the Unit.
1.0 metre from Discharge Grille.
The above data was measured in an anechoic chamber so that reflected sound should be taken into consideration in the field.
When bottom air inlet is adopted, sound pressure will increase according to factors such as installation mode and the room structure.

STRAINER KIT

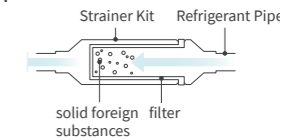

A strainer kit ensures that solid foreign substances, like small particles of metal, are caught before they enter the electric expansion valves of a wall-mounted indoor unit. Without the strainer kit's filter, these particles may prevent the valves from being fully sealed, creating a risk of explosive condensation when the unit becomes active.

WALL MOUNTED TYPE

(DC MOTOR TYPE) [RPK-HNBUSQ]



Model	RPK-0.8HNBUSQ	RPK-1.0HNBUSQ	RPK-1.3HNBUSQ	RPK-1.5HNBUSQ	RPK-1.8HNBUSQ	RPK-2.0HNBUSQ	RPK-2.3HNBUSQ	RPK-2.5HNBUSQ		
Indoor Unit Power Supply	AC 1Φ, 220~240V/50Hz, 220V/60Hz									
Nominal Capacity	Cooling	kW	2.2	2.8	3.6	4.0	5.0	5.6	6.3	7.1
	Heating	kW	2.5	3.3	4.0	4.5	5.6	6.3	7.1	8.0
Sound Pressure Level	(Hi/Me/Lo)	dB(A)	36/35/33/32/30/28	36/35/33/32/30/28	38/35/33/32/30/28	38/37/36/32/31/29	44/42/41/38/31/29	40/38/36/35/33/31	41/40/38/35/33/31	45/42/41/38/35/31
Color	White									
Outer Dimension	(H×W×D)	mm	270×815×203	270×815×203	270×815×203	315×915×230	315×915×230	315×1085×230	315×1085×230	315×1085×230
Net Weight		kg	9.0	9.0	9.0	12.5	12.5	14.0	14.0	14.0
Refrigerant			R410A	R410A	R410A	R410A	R410A	R410A	R410A	R410A
Indoor Fan Air Flow Rate	(Hi/Me/Lo)	m³/min	9.8/9.2/8.7/8.2/7.5/7.0	9.8/9.2/8.7/8.2/7.5/7.0	10.3/9.2/8.7/8.2/7.5/7.0	11.5/11.0/10.3/9.0/8.7/8.0	14.3/13.5/12.8/11.5/9.0/8.0	16.2/15.0/14.2/13.3/12.2/11.5	17.0/16.2/15.0/13.3/12.2/11.5	20.0/18.0/17.0/15.0/13.3/11.7
Connections	Flare-Nut Connection (with Flare Nuts)									
Refrigerant Piping Diameter	Liquid Line	mm	Φ6.35	Φ6.35	Φ6.35	Φ6.35	Φ6.35	Φ9.53	Φ9.53	Φ9.53
	Gas Line	mm	Φ9.53	Φ9.53	Φ9.53	Φ12.7	Φ12.7	Φ15.88	Φ15.88	Φ15.88
Condensate Drain			VP16	VP16	VP16	VP16	VP16	VP16	VP16	VP16
Approximate Packing Volume		m³	0.11	0.11	0.11	0.15	0.15	0.17	0.17	0.17

Receiver kit	Basic	PC-RLH11
	Advanced	PC-ALHZ1
Strainer kit		MSF-NP63A1

NOTES:

1. The cooling and heating capacities above show the maximum capacities when the outdoor and indoor temperature are under the following conditions.

Cooling Operation Conditions		Heating Operation Conditions	
Indoor Air Inlet Temperature:	27.0°C DB (80.0°F DB)	Indoor Air Inlet Temperature:	20.0°C DB (68.0°F DB)
	19.0°C WB (66.2°F WB)	Outdoor Air Inlet Temperature:	7.0°C DB (45.0°F DB)
Outdoor Air Inlet Temperature:	35.0°C DB (95.0°F DB)		6.0°C WB (43.0°F WB)
Piping Length: 7.5 metre		Piping Length: 7.5 metre	
Piping Lift: 0 metre		Piping Lift: 0 metre	

2. The sound pressure level is based on following conditions.

1.0 metre Beneath the unit.
1.0 metre from Discharge grille.
The above data was measured in an anechoic chamber so that reflected sound should be taken into consideration in the field.
When bottom air inlet is adopted, sound pressure will increase according to factors such as installation mode and the room structure.

GENERAL DATA & ACCESSORIES

FLOOR/CEILING CONVERTIBLE TYPE

(AC MOTOR TYPE) [RPFC-FSNQ]



Model	RPFC-1.8FSNQ	RPFC-2.0FSNQ	RPFC-2.3FSNQ	RPFC-2.5FSNQ	RPFC-3.0FSNQ	RPFC-3.3FSNQ	RPFC-4.0FSNQ	RPFC-5.0FSNQ		
Indoor Unit Power Supply	AC 1Φ, [220-240V/50Hz] [220V/60Hz]									
Nominal Capacity	Cooling	kW	5.0	5.6	6.3	7.1	8.4	9.0	11.2	14.2
	Heating	kW	5.6	6.5	7.5	8.5	9.6	10.0	13.0	16.3
Sound Pressure Level	Ceiling Mode	dB(A)	39/35/30	39/35/30	45/41/37	45/41/37	43/39/34	45/40/36	51/46/40	50/46/42
	Floor Mode	dB(A)	43/38/35	43/38/35	48/44/40	48/44/40	46/41/37	48/43/39	54/49/43	55/50/46
Outer Dimension	(H×W×D)	mm	230×990×680	230×990×680	230×990×680	230×990×680	230×1,285×680	230×1,285×680	230×1,285×680	230×1,580×680
Net Weight		kg	31	31	32	32	39	40	41	47
Refrigerant			R410A	R410A	R410A	R410A	R410A	R410A	R410A	R410A
Indoor Fan Air Flow Rate	(Hi/Me/Lo)	m³/h	780/660/540	780/660/540	966/840/678	966/840/678	1,092/912/732	1,164/978/798	1,488/1,230/978	1,980/1,680/1,380
Connections			Flare-Nut Connection (with Flare Nuts)							
Refrigerant	Liquid Line	mm	Φ6.35	Φ6.35	Φ9.52	Φ9.52	Φ9.52	Φ9.52	Φ9.52	Φ9.52
Piping Diameter	Gas Line	mm	Φ15.88	Φ15.88	Φ15.88	Φ15.88	Φ15.88	Φ15.88	Φ15.88	Φ15.88
Condensate Drain			VP25	VP25	VP25	VP25	VP25	VP25	VP25	VP25
Approximate Packing Volume		m³	0.31	0.31	0.31	0.31	0.40	0.40	0.40	0.48
Receiver kit	Basic		PC-RLH11							
	Advanced		PC-ALHZ1							

NOTES:

1. The cooling and heating capacities above show the maximum capacities when the outdoor and indoor temperature are under the following conditions.

Cooling Operation Conditions		Heating Operation Conditions	
Indoor Air Inlet Temperature:	27.0°C DB 19.0°C WB	Indoor Air Inlet Temperature:	20.0°C DB 7.0°C DB
Outdoor Air Inlet Temperature:	35.0°C DB	Outdoor Air Inlet Temperature:	6.0°C WB
Piping Length:	7.5 metre	Piping Length:	7.5 metre
Piping Lift:	0 metre	Piping Lift:	0 metre

2. The sound pressure level is based on following conditions.

- 1.0 metre Beneath the unit.
- 1.0 metre from Discharge grille.
- The above data was measured in an anechoic chamber so that reflected sound should be taken into consideration in the field.
- When bottom air inlet is adopted, sound pressure will increase according to factors such as installation mode and the room structure.

CEILING SUSPENDED TYPE

(DC MOTOR TYPE) [RPC-FSR]



Model	RPC-1.5FSR	RPC-2.0FSR	RPC-2.5FSR	RPC-3.0FSR	RPC-4.0FSR	RPC-5.0FSR	RPC-6.0FSR		
Indoor Unit Power Supply	AC 1Φ, [220-240V/50Hz] [220V/60Hz]								
Nominal Capacity	Cooling	kW	4.0	5.6	7.1	8.0	11.2	14.0	16.0
	Heating	kW	4.8	6.3	8.5	9.0	12.5	16.0	18.0
Sound Pressure Level	(Hi2/Hi/Me/Lo)	dB(A)	37/35/31/28	38/35/31/28	38/35/31/28	40/37/33/29	44/42/37/32	48/45/41/35	49/47/42/36
Color			Neutral White						
Outer Dimension	(H×W×D)	mm	235×960×690	235×960×690	235×1,270×690	235×1,270×690	235×1,580×690	235×1,580×690	235×1,580×690
Net Weight		kg	26	27	35	35	41	41	41
Refrigerant			R410A	R410A	R410A	R410A	R410A	R410A	R410A
Indoor Fan Air Flow Rate	(Hi2/Hi/Me/Lo)	m³/min	15/13/11/9	15/13/11/9	19/16.5/14/11.5	21/18.5/15.5/12.5	30/26.5/22/17	35/31/25.5/20	37/32.5/27/21
Connections			Flare-Nut Connection (with Flare Nuts)						
Refrigerant	Liquid Line	mm	Φ6.35	Φ6.35	Φ9.52	Φ9.52	Φ9.52	Φ9.52	Φ9.52
Piping Diameter	Gas Line	mm	Φ12.7	Φ15.88	Φ15.88	Φ15.88	Φ15.88	Φ15.88	Φ15.88
Condensate Drain			VP20	VP20	VP20	VP20	VP20	VP20	VP20
Approximate Packing Volume		m³	0.23	0.23	0.31	0.31	0.38	0.38	0.38
Receiver kit	Advanced		PC-ALHP1						
Motion Sensor			SOR-NEP						
Condensate Drain Pump Kit	1.5 (HP Class)		DUPC-63K1						
	2.0 (HP Class)		DUPC-71K1						
	2.5-6.0 (HP Class)		DUPC-160K1						
ViroSense S filter			-(Standard)						

NOTES:

1. The cooling and heating capacities above show the maximum capacities when the outdoor and indoor temperature are under the following conditions.

Cooling Operation Conditions		Heating Operation Conditions	
Indoor Air Inlet Temperature:	27.0°C DB 19.0°C WB	Indoor Air Inlet Temperature:	20.0°C DB 7.0°C DB
Outdoor Air Inlet Temperature:	35.0°C DB	Outdoor Air Inlet Temperature:	6.0°C WB
Piping Length:	7.5 metre	Piping Length:	7.5 metre
Piping Lift:	0 metre	Piping Lift:	0 metre

2. The sound pressure level is based on following conditions.

- 1.0 metre Beneath the unit.
- 1.0 metre from Discharge grille.
- The above data was measured in an anechoic chamber so that reflected sound should be taken into consideration in the field.
- When bottom air inlet is adopted, sound pressure will increase according to factors such as installation mode and the room structure.

FLOOR CONCEALED TYPE

(AC MOTOR TYPE) [RPFI-FSNQ]



Model	RPFI-1.0FSNQ	RPFI-1.5FSNQ	RPFI-2.0FSNQ	RPFI-2.5FSNQ		
Indoor Unit Power Supply	AC 1Φ, [220-240V/50Hz]					
Nominal Capacity	Cooling	kW	2.8	4.3	5.6	7.1
	Heating	kW	3.3	4.9	6.5	8.5
Sound Pressure Level	(Hi/Me/Lo)	dB(A)	37/34/31	40/38/35	42/38/36	45/43/40
Outer Dimension	(H×W×D)	mm	620×900×202	620×900×202	620×1,170×202	620×1,170×202
Net Weight		kg	25	26	34	34
Refrigerant			R410A	R410A	R410A	R410A
Indoor Fan Air Flow Rate	(Hi/Me/Lo)	m³/min	8.5/7/6	12/8/7	16/12.5/10.5	16/14/11
Connections			Flare-Nut Connection (with Flare Nuts)			
Refrigerant	Liquid Line	mm	Φ6.35	Φ6.35	Φ6.35	Φ9.52
Piping	Gas Line	mm	Φ12.70	Φ12.70	Φ15.88	Φ15.88
Condensate Drain			VP25	VP25	VP25	VP25
Packaging Volume		m³	0.19	0.19	0.23	0.23
Receiver kit	Basic		PC-RLH11			
	Advanced		PC-ALHZ1			

NOTES:

1. The cooling and heating capacities above show the maximum capacities when the outdoor and indoor temperature are under the following conditions.

Cooling Operation Conditions		Heating Operation Conditions	
Indoor Air Inlet Temperature:	27.0°C DB 19.0°C WB	Indoor Air Inlet Temperature:	20.0°C DB 7.0°C DB
Outdoor Air Inlet Temperature:	35.0°C DB	Outdoor Air Inlet Temperature:	6.0°C WB
Piping Length:	7.5 metre	Piping Length:	7.5 metre
Piping Lift:	0 metre	Piping Lift:	0 metre

2. The sound pressure level is based on following conditions.

- 1.0 metre from the unit.
- 1.0 metre from floor level.
- Voltage of the power source for the indoor fan motor is 220V.
- The above data was measured in an anechoic chamber.



VENTILATIONS

RENEW AIR

Today, the average person spends more than 75% of their day indoors; at home, at work, in the gym, shopping or socializing. Many of these environments are effectively sealed and fresh air isn't easily available

Without proper ventilation, CO2 levels rise, pollutants circulate and potentially harmful bacteria build-up, impacting on the wellbeing, comfort and productivity of occupants.

Make these spaces as healthy and comfortable as possible by providing fresh air with our premium air renewal systems for commercial buildings

OUR LINE-UP

Our line-up fulfils the ventilation requirements of the desired space by drawing in clean air from the outside and replenishing indoor spaces. It features solutions that suit every type of building; You can use the ventilation technology as it is or it can be incorporated into a Hitachi indoor unit via the fresh-air port. Thanks to accessories like this, you can optimize the design of your system to meet your needs.

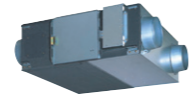

TOTAL HEAT EXCHANGER

- Creates a healthy indoor environment thanks to introducing fresh air function and ventilation function
- Remote controller for Total Heat Exchanger is equipped in unit as standard part

Fan Air Flow Rate (m³/h)	150	200	210	230	300	400	500	550	650	700	800	1,000	1,080	1,250	1,500	1,680	2,000	2,100	2,500	3,000	4,000	5,000	6,000	
TOTAL HEAT EXCHANGER	●	●	●	●	●	●	●	●	●	●	●	●	●	●	●	●	●	●	●	●	●	●	●	●

Model		KPI-20H-A-GQ	KPI-30H-A-GQ	KPI-40H-A-GQ	KPI-50H-A-GQ	KPI-65H-A-GQ	KPI-80H-A-GQ	KPI-100H-A-GQ	KPI-125H-A-GQ	
Unit Power Supply		AC 1Φ, [220/50Hz]								
Temp. Efficiency	Summer (Hi/Me/Lo)	%	64/64/70	60/60/65	61/61/66	60/60/62	65/65/69	65/65/69	65/65/69	65/65/69
	Winter (Hi/Me/Lo)	%	80/80/83	77/77/80	79/79/81	75/75/76	75/75/78	74/74/78	72/72/76	70/70/78
Enthalpy Efficiency	Summer (Hi/Me/Lo)	%	69/69/76	63/63/70	64/64/69	63/63/65	57/57/60	60/60/63	58/58/63	53/53/61
	Winter (Hi/Me/Lo)	%	75/75/78	70/70/75	70/70/75	69/69/71	65/65/70	70/70/72	66/66/69	63/63/72
Sound Pressure Level	(Hi/Me/Lo)	dB(A)	32/30/25	36/34/28	39/37/30	40/38/31	40/38/35	40/38/34	43/42/34	42/40/37
Outer Dimension	(H×W×D)	mm	220×962×735	220×962×735	220×1,112×735	220×1,112×735	388×1,119×884	388×1,119×884	388×1,119×884	430×1,250×1,135
Net Weight		kg	38	40	46	52	61	69	69	95
Air Flow Rate	(Hi/Me/Lo)	m³/h	200/200/150	300/300/210	400/400/230	500/500/400	650/650/550	800/800/650	1,000/1,000/700	1,250/1,250/800
External Static Pressure	(Hi/Me/Lo)	Pa	100/70/40	120/90/50	120/90/50	120/90/50	130/100/90	130/100/90	165/120/60	100/50/30
Power Input	(Hi/Me/Lo)	W	120/110/75	165/155/120	210/200/130	330/310/230	2×(188/173/142)	2×(207/188/165)	2×(250/228/205)	2×(308/266/237)
Current	(Hi/Me/Lo)	A	0.6/0.5/0.4	0.8/0.7/0.6	1.0/1.0/0.7	1.6/1.5/1.1	1.72/1.58/1.31	2.04/1.93/1.73	2.35/2.09/1.92	3.03/2.45/2.18
Connection Duct Diameter		mm	Φ144	Φ144	Φ144	Φ194	Φ242	Φ242	Φ242	320×250 +320×250
Approximate Packing Volume		m³	0.37	0.37	0.43	0.49	0.94	1.15	1.15	1.25

Model		KPI-150H-E-GQ	KPI-200H-E-GQ	KPI-250H-E-GQ	KPI-300H-E-GQ	KPF-400H-E-GQ	KPF-500H-E-GQ	
Unit Power Supply		AC 3Φ, [380/50Hz]						
Temp. Efficiency	Summer	%	63	63	63	63	63	
	Winter	%	68	72	75	75	73	
Enthalpy Efficiency	Summer	%	57	57	55	56	55	
	Winter	%	68	68	72	72	63	
Sound Pressure Level		dB(A)	50	51	53	54	57	
Outer Dimension	(H×W×D)	mm	536×1,500×1,300	536×1,500×1,400	640×1,700×1,500	640×1,750×1,600	1,655×1,400×850	1,730×1,700×850
Net Weight		kg	144	155	180	220	225	260
Air Flow Rate		m³/h	1,500	2,000	2,500	3,000	4,000	5,000
External Static Pressure		Pa	165	160	180	200	220	240
Power Input		W	2×440	2×810	2×925	2×1080	2×1,470	2×1,980
Current		A	2.84	3.08	4.19	5.23	5.57	7.51
Connection Duct Diameter		mm	400×320 +400×320	400×320 +400×320	500×350 +500×350	500×350 +500×350	400×320 +590×320	500×350 +700×320
Approximate Packing Volume		m³	1.82	1.95	2.63	2.93	3.01	3.75

NOTE:
Please confirm the model name for "wires remote controller" compatible with Total Heat Exchanger to your local distributor.



CONTROLLERS

New generation: simple and smart!

Everyone deserves comfort, but comfort does not mean the same to everyone. That's why control is key. Our controllers offer best-in-class simplicity. Using our praised central stations, building managers can instantly optimize air conditioning in targeted zones. For occupants, our new advanced color controller provides intuitive navigation with a premium design.

With airCloud Pro, our exclusive new-generation solution, users can manage from one indoor unit to several systems remotely via IoT (web/smartphone).

63 CENTRALIZED CONTROLLERS

- 63 Line up overview
- 65 airCloud Pro
- 67 Central Station EX
- 68 Central Station EZ
- 68 Central Station mini

69 INDIVIDUAL CONTROLLERS

- 69 Line up overview
- 71 airCloud Tap
- 73 Advanced Color Wired Remote Controller
- 75 Eco-Compact Controller
- 77 Wired remote controller
- 78 Advanced wireless remote controller
- 78 Wireless remote controller
- 78 Receiver kit

79 ACCESSORIES

81 H-LINK: ENJOY MORE FREEDOM

CENTRALIZED CONTROLLERS

Control each indoor unit, one specific zone or even multiple systems from one place!



airCLOUD PRO* (HC-IOGW)

- Remote access via smartphone app or web.
- Unlimited number of systems, zones and users.
- Intuitive scheduling function.
- Troubleshooting with access to error history and alerts.
- Filter sign display to quickly overview daily maintenance needs.
- Ideal for all types of applications.

CENTRAL STATION EZ (PSC-A64GT)

- Control capacity: max 64 remote control group of indoor units.
- Compact and optimized 170x250mm body screens fitting in even small walls.
- Easy monitoring with simplified interface.
- Best option for middle size buildings.

CENTRAL STATION EX (PSC-A128EX3)

- Control capacity: max 2,560 indoor units (+15x Extension Adapter PSC-AD128EX3).
- With energy calculation software (PSC-AS01EXC), determine each tenant's energy usage.
- Easy monitoring with simplified interface.
- Best option for middle-large size buildings.
- Remote access! Operate Central Station EX from your laptop PC or touch-panel PC.

CENTRAL STATION MINI (PSC-A32MN)

- Control capacity: max 32 remote control group of indoor units.
- Compact and optimized 120x140mm body screens fitting in even small walls.
- Easy monitoring with simplified interface.
- Best option for small size buildings.

Small to large systems & fixed or cloud-based



		HC-IOGW	PSC-A128EX3	PSC-A64GT	PSC-A32MN	
Capacity comparison	Total Connection capacity	RC group	64 (*6)	2,560 (*1)	64	32
		Group	64 (*6)	2,048 (*1)	64	32
		Block	Unlimited (*7)	512 (*2)	4	2/4/8/16
		Area	Unlimited (*7)	512 (*2)	-	-
		Indoor unit	80 (*6)	2,560 (*1)	160	160
	Outdoor unit	16 (*6)	1,024 (*1)	64	64	
	Building scale	Small to Large	Large	Medium	Small	
	Operation	Web + Mobile Phone	Touch screen + Web (New!)	Touch screen	Touch screen	
Display	Operation panel size options	Adaptive	7	2	3	
	Layout	-	●	-	-	
	List options	-	3	-	-	
Operation unit	All together	●	●	●	●	
	By layout	-	●	-	-	
	By area	●	●	-	-	
	By block	●	●	●	●	
	By group	●	●	-	-	
	By RC group	-	-	●	●	
	By indoor unit	●	●	-	-	
Control Function	Main 5 functions (*5)	●	●	●	●	
	Individual controller lock	●	●	△ (*3)	●	
	Filter sign reset	●	●	●	●	
	Outdoor unit capacity control	-	●	-	△ (*4)	
Monitor Function	Outdoor unit noise control	-	●	-	-	
	Main 5 functions (*5)	●	●	●	●	
	Individual controller lock	●	●	●	●	
	Alarm status & code	●	●	●	●	
	Filter sign	●	●	●	●	
	Air inlet temperature of indoor unit	-	●	-	●	
	Air inlet temperature of outdoor unit	-	●	-	●	
Schedule Function	Frostwash status	-	●	-	-	
	Weekly	●	●	●	-	
	Setting times per day	16	16	10	10	
	Special day setting	5	5	-	-	
	Holiday setting	-	●	-	-	
Other function	Annual/Summer/Winter schedule	Future Version	●	-	-	
	Alarm history (records number)	Unlimited	10,000	100	100	
	External in/output history	-	1,000	-	-	
	Management report visualization(*11)	Energy Estimation (*8) - Future	●	●	●	
	Data output by external media	Download from Web - Future	SD card, USB flash device	-	-	
IoT Functions	Individual WRC clock synchronization	-	●	-	-	
	Connectivity	Ethernet + 4G (*9)	-	-	-	
	Future Extendability	Firmware OTA (*10) Web + Mobile Update	-	-	-	

(*1) One Extension Adapter (PSC-AD128EX3) enable CENTRAL STATION EX to control additional 160 RC groups /128 groups / 160 IDUs / 64 ODUs, and up to 15 adapters can connect to one Central Station EX.

(*2) No restriction on the number of H-LINK.

(*3) Individual Feature Control in Each Remote Controller is not available.

(*4) Applicable only with Schedule function or external signal input. You cannot set it up directly from monitoring panel.

(*5) Main 5 functions meaning: 1) Run/Stop 2) Operation mode 3) Temperature setting 4) Fan speed 5) Louver control.

(*6) Ability to connect unlimited number of "HC-IOGW" in one project and control all AC units via one single screen on Web or Mobile Phone.

(*7) Unlimited creation of zones, across multiple "HC-IOGW" units within the same project.

(*8) Visualization of outdoor unit energy consumption.

(*9) 4G available through optional 4G module; 4G module package comes with global SIM and pre-paid global data plan.

(*10) OTA: Over-the-air firmware update, provides always up-to-date firmware and latest functionalities.

(*11) Mini, EZ: Accumulated operation time (min), Accumulated thermo - ON (min).

EX: Accumulated operation time (min), Accumulated thermo - ON time (min), Average air intake temperature of indoor unit, Average air intake temperature of outdoor unit, Average setting temperature, Average RC sensor temperature.

CENTRALIZED CONTROLLERS

airCLOUD PRO*

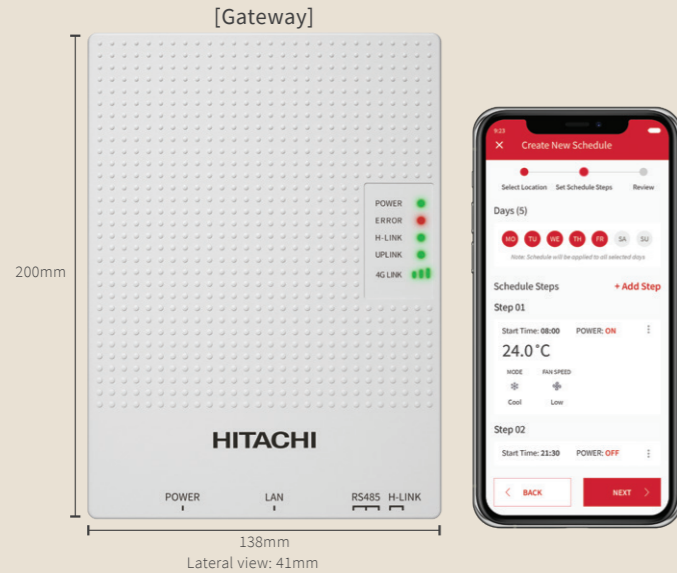

Specifications

Gateway	HC-IoTGW
Net weight (g)	540
Connection capacity	16 outdoor + 80 indoor units
Power supply (V) (Hz)	100-240, AC 50/60
Max. power consumption (W)	10
Communication port	1 H-LINK, 1 RS485 Port
Internet connection	LAN (Ethernet) or 4G ³
External interface (log storage)	1 micro SD card slot

Functions

IoT connection (cloud-based)	<ul style="list-style-type: none"> • Access via smartphone app or web • Unlimited number of gateways • Unlimited number of locations • Unlimited number of users
Operation unit	<ul style="list-style-type: none"> • Per entire location • Per system • Per zone (unlimited zone creation) • Per indoor unit remote control group
Control function	<ul style="list-style-type: none"> • On/Off • Mode • Set temperature • Fan speed • Louver • RC lock • Filter sign reset

Monitor Function	<ul style="list-style-type: none"> • On/Off • Mode • Set temperature • Air intake temperature • RC sensor temperature (*3) • Air intake temperature of outdoor unit • Fan Speed • Louver • RC prohibition • Thermo-ON information • Filter sign/Auto cleaning fault • Alarm status/Alarm codes
Schedule function	<ul style="list-style-type: none"> • Weekly schedule • Easy selection of days and zones • Setting items in schedule is as below; • On/Off • Operation mode • Setting temperature • Louver • Fan speed

*All Groups Run/Stop" command signal exception function for selected groups is available by "Exception of Run/Stop Operation." function.

System configuration.



Recommended facilities (examples.)



Is airCloud Pro for me?

All VRF users can enjoy these benefits!

- Save energy
- Save time and unnecessary transportation
- Delegate VRF systems administration
- Create a comfortable climate for guests

Future-proof

With updates and new features added regularly, airCloud Pro ensures you are always up to date.

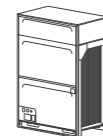

- Compatible with new and former
- Hitachi Variable Refrigerant
- Flow systems*1

Control is in your hands.
24/7 control at your fingertips on smartphone, tablet, or PC.

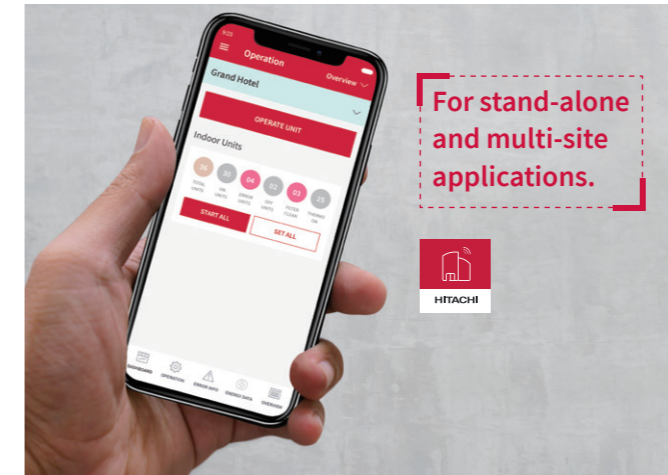

✓ Intuitive simplicity

airCloud Pro is designed to make your job easier. An intuitive app that anyone can use, airCloud Pro makes managing your VRF systems easier than ever before.

✓ Control from anywhere

Enjoy the freedom of remote access from your smartphone, tablet or laptop. airCloud Pro allows you to remotely control your VRF system(s) from a single app, saving you travel time.

A simple yet powerful tool.

👍 Simplify your job

The pilot app makes managing your VRF systems easy.

- **Centralized control**
Control your entire VRF system or selected zones in one touch.
- **Simplified troubleshooting**
A clear error history, concise error description and follow-up.
- **Smartphone alerts²**
In the event of a critical malfunction.
- **Flexible user management²**
Add users and custom access restrictions.

🌐 Save more energy

Monitor energy consumption and optimize usage.

- **Energy consumption data²**
Simple graphs visualize power consumption.
- **Intuitive scheduling**
Plan operations ahead based on your business hours.
- **Individual controller lock**
Prevent inappropriate usage from occupants.

❤️ Create better comfort

Adjust temperature, fan speed, and modes with ease, creating total comfort and the ideal climate throughout your building.

An integrated weather forecast^{*2} display helps you determine the most suitable conditions for your indoor spaces all year round.

🔗 Easy plug-and-play

Our airCloud gateway makes installation a breeze.

Connect to the airCloud via 3G/4G^{*3} or ethernet and pair your VRF systems via QR code scan. With automatic detection of indoor units and an optimized installer view, configuring your site and zones has never been quicker.

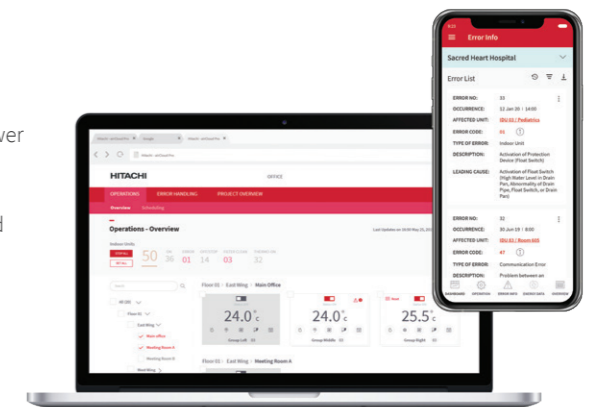

+ data security

Best-in-class standards:
TLS.v1.2, HTTPS 2038 encryption.

Minimal personal details:
Only your name, email address and phone number are required for login.

*1 Confirm compatibility of your VRF installation with your Hitachi Cooling & Heating representative.

² Functions not available as of September 2019, coming soon.
³ 4G module available as a side accessory.

CENTRALIZED CONTROLLERS

CENTRAL STATION EX FOR LARGE-SCALE BUILDINGS (PSC-A128EX3)



Capacity

H-LINK	16
RC group	2,560 (*1)
Group	2,048 (*1)
Block	512 (*2)
Area	512 (*2)
Indoor unit	2,560 (*1)
Outdoor unit	1,024 (*1)
Building scale	Large

Extension adapter



PSC-AD128EX3

(*1) 1 extension adapter (PSC-AD128EX1) enables Central Station EX to control additional 160 RC groups / 128 groups / 160 IDUs / 64 ODUs. Central Station EX can connect up to 15 adapters.

(*2) No restriction on the number of H-LINK

Energy calculation software*



PSC-AS01EXC

Specifications

Rated power supply	100~240VAC ±10% (50/60Hz)
Electrical power consumption	50W (Max.)
Communication unit	Units of Adopting for H-LINK
Communication line	Two-wire non-polar
Communication speed	9,600bps
Wiring length	1,000m (Total Length)
Display	12.1 inch TFT color liquid crystal display
Display control	Touch Panel

For middle or large-scale buildings such as hotels, educational facilities, and hospitals, our Central Station EX features a highly intuitive and functional 12.1-inch wide, wall-mountable, color LCD screen.

Control up to 2,560 indoor units with our proprietary H-LINK system with 15 extension adapters (PSC-AD128EX3).

Also, with energy calculation software (PSC-AS01EXC), Central Station EX can help you easily manage each tenant's electricity & report the power consumption of VRF system for each tenant.

Install by add-on software and activate, then, you can select electricity ratio or usage ratio from several methods.

Functions

Operation unit	All together Each area Each block Each group Each indoor unit	Each of the following settings is available in 3 different [annual] [summer][winter] categories: → Weekly schedule → Up to 16 actions can be set per day → Exception day setting: 5 different types → Holiday setting	Energy saving: • Run/Stop • RC prohibition • Temperature shift (For Cool/Dry mode: +1.0°C~+9.0°C (+1.0°F~+18.0°F)) (For Heat mode: -1.0°C~-9.0°C (-1.0°F~-18.0°F)) • Mode shift (Mode shifted to Fan when in Cool/Dry mode, and shifted to Stop in Heat mode) • Capacity control on outdoor units • Lower noise control for outdoor units
Control function	On/Off Mode Set temperature Fan speed Louver RC prohibition Filter sign reset Function selection for indoor units (*1) Function selection for outdoor units (*2) Capacity control for outdoor units (*2) Lower noise control for outdoor units (*2)	Schedule function Setting items in schedule is as below: • On/Off • Operation mode • Setting temperature • Louver • Fan speed • RC operation prohibition • Capacity control for outdoor units • Lower noise control for outdoor units	External input / output Control/Monitor → Controlled items: • Run/Stop • Mode (Cool/Heat) → Monitored items: • Run/Stop • Mode (Cool/Heat) • Alarm state
Monitor function	On/Off Mode Set temperature Air intake temperature RC sensor temperature (*3) Air intake temperature of outdoor unit Fan Speed Louver RC prohibition Thermo-ON information Filter sign/Auto cleaning fault Alarm status/Alarm codes	History Alarm history: 10,000 records External In/Output history: 1,000 records Pulse input history: 6 months	Others: • Power consumption signal input • Emergency stop
	Management report visualization Up to 2 years worth of data history can be displayed for the following: • Accumulated operation time (min.) • Accumulated thermo-ON time (min.) • Average air intake temperature of indoor unit • Average air intake temperature of outdoor unit • Average setting temperature • Average RC sensor temperature		

(*1) Some indoor units may not fully support all functions.
(*2) Available for applicable outdoor units only.
(*3) Whether this is shown on the screen depends on the remote controller settings.

Remote access.

You can now operate Central Station EX from your laptop PC or touch panel PC. Install our software and you can connect from anywhere, using our VPN network.

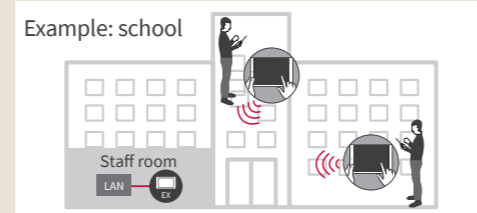

CENTRAL STATION EX FOR MEDIUM-SCALE BUILDINGS (PSC-A64GT)



Capacity

RC group	64
Group	64
Block	4
Indoor Unit	160
Outdoor Unit	64
Building Scale	Small-Medium

Specifications

Rated Power Supply	1-, AC 100-240V, 50/60Hz
Electrical Power Consumption	30W (Max.)
Communication Unit	Units of Adopting for H-LINK
Communication Line	Non-polar 2-wire
Communication Speed	9,600bps
Wiring Length	1,000m (Total Length)
Display	8.5-inch Wide Color LCD (Full Dot)
Display Control	Touch Panel

Functions

Monitor Function	• Run/Stop/Abnormality • Setting Temperature • RC Operation Prohibited Setting • Accumulated Operating Time • Operation Mode • Setting Fan Speed • Setting Louver • Filter Sign • Alarm Code
Control Function	• Run/Stop* • Fan Speed • Operation Mode • Louver • Temperature Setting • RC Operation Prohibited • Filter Sign Reset

*The "All Groups Run/Stop" command signal exception function for selected groups is available via the "Exception of Run/Stop Operation" function.

With easy control via an 8.5 inch color touch panel, its detailed control functionalities such as Weekly Scheduling, Operation hours tracking, and more, help you save energy. Up to 64 remote-controlled groups and up to 160 indoor units can be connected to the Central Station EX.

CENTRAL STATION MINI FOR SMALL-SCALE BUILDINGS (PSC-A32MN)



Capacity

RC group	32
Group	32
Block	4 Patterns (2/4/8/16)
Indoor Unit	160
Outdoor Unit	64
Building Scale	Small

Specifications

Rated Power Supply	1-, AC 100-240V, 50/60Hz
Electrical Power Consumption	20W (Max.)
Communication Unit	Units of Adopting for H-LINK
Communication Line	Non-polar 2-wire
Communication Speed	9,600bps
Wiring Length	1,000m (Total Length)
Display	5.0-inch Wide Color LCD (Full Dot)
Display Control	Touch Panel

Functions

Monitor Function	• Run/Stop/Abnormality • Setting Temperature • RC Operation Prohibited Setting • Accumulated Operating Time • Operation Mode • Setting Fan Speed • Setting Louver • Filter Sign • Alarm Code"
Control Function	• Run/Stop* • Fan Speed • Operation Mode • Louver • Temperature Setting • RC Operation Prohibited • Filter Reset Signal

*"All Groups Run/Stop" command signal exception function for selected groups is available by "Exception of Run/Stop Operation." function.

With easy control via an 5.0 inch color touch panel, its detailed control functionalities such as weekly scheduling, operation hours tracking, help you save energy. Up to 32 remote-controlled groups and up to 160 indoor units can be connected to the Central Station mini.

INDIVIDUAL CONTROLLERS

A new generation of room controller now available!

With two new room controllers, the experience of controls has become easier and more stylish than ever

NEW ADVANCED-COLOR CONTROLLER (PC-ARFG1-*)



Contactless settings via airCloud Tap

Complete controls in a rich interface

- Colored screen displaying visual charts and descriptive texts
 - Access to all existing Hitachi VRF indoor unit features including user features settings, installation & maintenance features settings.
 - Energy consumption monitoring
 - Ideal for indoor units with motion sensors, cassettes with elevating grilles
 - Multiple languages available
- *Except Sleep Mode timer

NEW ECO-COMPACT CONTROLLER (PC-ARC-*)



Contactless settings via airCloud Tap

Value without compromise

- Segment screen displaying pictograms
- Essential controls in a glimpse
- On/Off weekly schedule
- Some extra advanced features such as GentleCool, Power-Saving Peak-Cut mode and Sleep Mode Timer
- Embedded IR receiver, ideal for ducted units

Still available for order

WIRED REMOTE CONTROLLER (HCWA10NEGQ)



- 88mm square controller with LCD screen.
- Smaller body with multiple features.
- Best option for spaces frequented by recurring users, e.g. offices.

Controls from anywhere in the room

ADVANCED WIRELESS REMOTE CONTROLLER (PC-AWR)



- Wireless remote controller with more features.
- Several temperature units and settings available; 0.5°C/1.0°C/1.0°F.
- Ideal for controlling the unit from anywhere in the room, e.g. residential spaces.

WIRELESS REMOTE CONTROLLER (PC-LH7QE)



- Budget option featuring primary control settings.
- 1.0°C temperature step.
- Ideal for visitors to control the unit from anywhere in the room, e.g. hotel suite.

From basic to advanced controls

		NEW PC-ARFG1	NEW PC-ARC	HCWA10NEGQ	PC-AWR	PC-LH7QE
Connection Capacity	No of RC-Group No of indoor units	1 16	1 16	1 16	- -	- -
Product Size	Width*Height*Depth (mm) (D: thinnest part)	120*120*16.5 (D: thinnest part)	90*90*15.5 (D: thinnest part)	88*88*15.5	140*55*16.8	140*52*19.3
Screen		Color LCD with backlight	Segment LCD with backlight	Segment LCD with backlight	Segment LCD	Segment LCD
Embedded IR receiver		-	●	-	-	-
Smartphone App	Use With AirCloud Tap	● (support NFC)	● (support NFC)	-	-	-
Essential Operations	Run / Stop	●	●	●	●	●
	Operation Mode	●	●	●	●	●
	Auto Mode Setting	●	●	●	●	●
	Temperature Setting	●	●	●	●	●
	Fan Speed	●	●	●	●	●
	Louver Direction	●	●	●	●	●
	Simple Timer	●	● (On/Off Timer)	● (On/Off Timer)	● (On/Off Timer)	● (On/Off Timer)
	Weekly Operation Schedule	●	●	-	-	-
	Power Savings Setting	●	● (Capacity Control only)	-	-	-
	Night Quiet Operation	●	-	-	-	-
Advanced Feature Settings	Power Savings/Night Quiet Schedule	●	-	-	-	-
	Power Consumption Display	●	-	-	-	-
	AutoBoost	●	●	-	-	-
	Comfort Setting	●	● (GentleCool only)	-	-	-
	Sleep Mode	-	●	-	-	-
	Motion Sensor Setting (1)	●	-	-	-	-
	Setback Setting	●	-	-	-	-
	Elevating Grille	●	-	-	-	-
	Filter Reminder Time Reset	●	●	●	●	●
	Filter Auto-Cleaning (1)	●	-	-	-	-
Display Settings	FrostWash Setting (1)	●	-	-	-	-
	Individual Louver Setting	●	●	●	-	-
	Louver Open/Close	●	-	-	-	-
	Ventilation	●	-	-	-	-
	Total Heat Exchanger SET	●	-	-	-	-
	Adjusting Date/Time	●	●	●	-	-
	Daylight Saving Time	●	-	-	-	-
	Run Indicator Brightness Adjustment	●	● (Only On/Off setting)	-	-	-
	Display Adjustment	●	-	-	-	-
	Temperature Units (°C/°F)	●	●	●	●	- (°C only)
Service Functions	Temperature setting at 0.5°C step	●	●	●	●	- (1.0°C only)
	Room Temperature Display	●	●	●	-	-
	Language available	EN, JPN, CN (traditional & simplified), FR, ES, PT	EN	EN	EN	EN
	Keypad Touch Sound	●	●	● (Cannot turn off)	-	-
	Lock Function	●	● (Lock function individually)	● (Lock whole keypad)	-	-
	Power Saving Details Setting	●	-	-	-	-
	Temperature Range Restriction	●	● (in Function Selection)	● (in Function Selection)	-	-
	Dual Setpoint	●	-	-	-	-
	Main/Sub Display	●	-	-	-	-
	Set Room Name	●	-	-	-	-
Installation Functions	Set Contact Information	●	-	-	-	-
	NFC Setting	●	●	-	-	-
	Simple Maintenance Check Menu	●	-	-	-	-
	Test Run	●	●	●	-	-
	Function Selection	●	●	●	-	-
	Thermistor Selection	●	● (in Function Selection)	● (in Function Selection)	-	-
	Input/Output	●	●	●	-	-
	Thermistor Calibration in Controller	●	● (in Function Selection)	-	-	-
	Fan Speed At Thermo-Off	●	● (in Function Selection)	● (in Function Selection)	-	-
	Indoor Unit Address Change	●	●	●	-	-
Check Menu	Address Check Operation	●	-	-	-	-
	Address Initialization	●	-	-	-	-
	Setting Initialization	●	-	-	-	-
	Main/Sub Controller Setting	●	●	●	-	-
	Priority Setting	●	-	-	-	-
	Cancel Preheating Control	●	-	-	-	-
	Elevating Grille Setting	●	-	-	-	-
	Power Up Setting	●	-	-	-	-
	Setback Trigger Unit	●	-	-	-	-
	Refrigerant Leak Sensor Setting	●	-	-	-	-
Other features	Check 1	●	●	●	-	-
	Check 2	●	●	●	-	-
	Alarm History Display	●	●	●	-	-
	Display Model Number	●	-	-	-	-
	Check PCB of the Units	●	-	-	-	-
Other features	Self Check	●	●	●	-	-
	Synchronize Date/ time with Central Controller	● (Only available from Central Station EX PSC-A128EX3)	● (Only available from Central Station EX PSC-A128EX3)	-	-	-
	Stop operation delay	●	●	-	-	-
	Emergency operation	●	●	-	-	-
	Two WRC Control	●	●	-	-	-
Alarm Display	●	●	●	-	-	
Filter cleaning reminder sign display	●	●	●	-	-	

(*1) Available when the controller is connected with selected indoor unit offering this feature.

INDIVIDUAL CONTROLLERS



For HVAC professionals:
Quicker commissioning & service by airCloud Tap
Contactless 'read and write' settings

Ready-to-tap controllers

- NFC chip embedded in the controller

Convenience using with a mobile app

- Easy browsing of all settings by scrolling phone's screen
- Complete text description of each setting

More savvy than traditional settings by physical device

- Less buttons to press, no AC hardware to manipulate
- Time saving setting process
- Reduced need of documentation support



What you can do with airCloud Tap | some highlights:

Installation & Commissioning



Date/time setting

Import the date & time from your phone into the controller

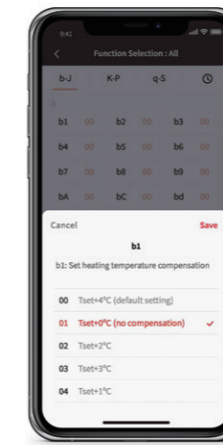

Function selection

Scroll your phone's screen and browse over 140 commissioning settings available

Operation

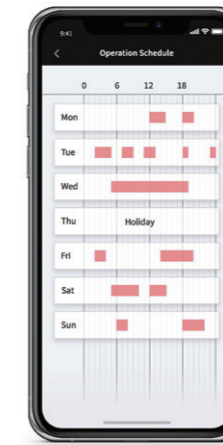

Scheduling

Save preferred AC schedule and save to copy to other controllers of the same building

Maintenance & Service

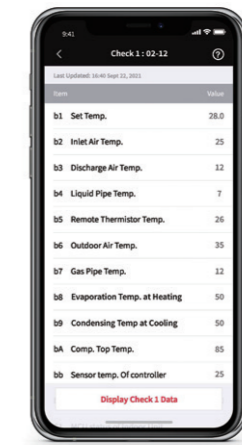

Troubleshooting

Visualize all the service check data on your phone

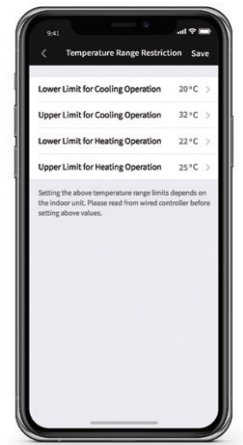

Temperature range restrictions

Apply min/max set temperature to prevent excessive cooling/heating

Special tip: Save time on multi-room commissioning

Specify settings for one room, save them, then apply these settings to other similar rooms in one tap. Particularly useful for multiple zones with similar needs! Hotel guestrooms, office meeting rooms, condominium units, etc.

How does airCloud Tap works?



1. Activate the NFC function on the AC equipment.

2. Open the airCloud Tap app and tap the AC equipment with your phone to read the current settings.

3. Edit the desired settings on your phone.

4. Tap again your equipment to apply the new settings.

STEP1
Read the settings from one device and save settings.

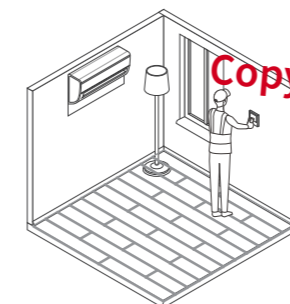

STEP2
Hold the mobile device over each product and write settings of STEP1.

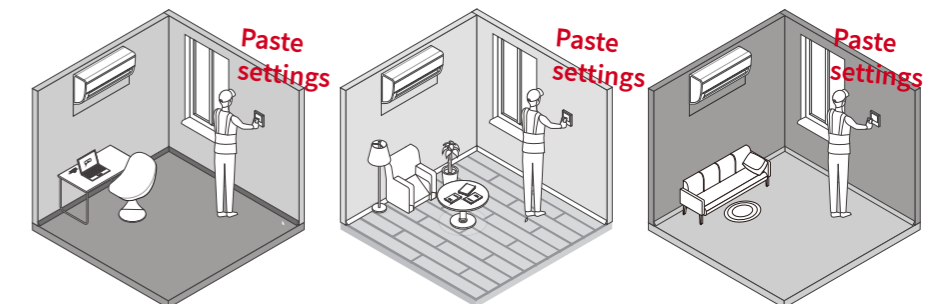

INDIVIDUAL CONTROLLERS

NEW ADVANCED COLOR WIRED REMOTE CONTROLLER (PC-ARFG1)

Simplicity with style

Combining the best of form and function, enjoy climate control made easy with Hitachi's most advanced wall controller yet.



- Super user-friendly interface
- Easy-to-navigate menus
- Available in 7 languages
- Pictograms and colors for an optimal user experience

Award-winning design

- Minimalist design aesthetic
- Distinctive curves for ergonomics
- Modern and subtle colors

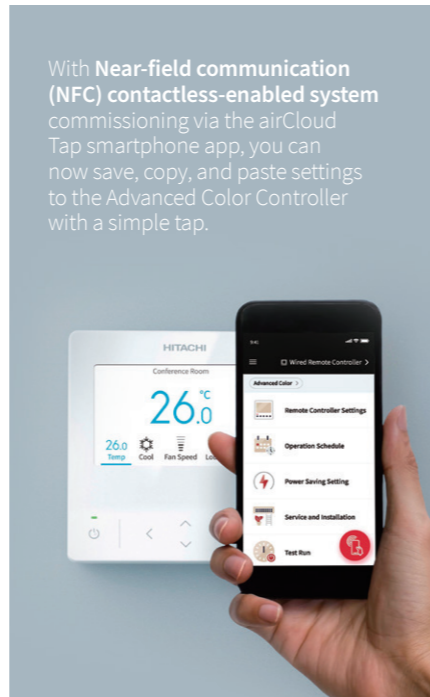

With **Near-field communication (NFC) contactless-enabled system** commissioning via the airCloud Tap smartphone app, you can now save, copy, and paste settings to the Advanced Color Controller with a simple tap.



- 1 Room name
- 2 Set temperature
- 3 Operation mode
- 4 Indoor unit ON/OFF light
- 5 Indoor unit ON/OFF
- 6 Navigation buttons
- 7 Back button
- 8 OK button
- 9 Fan speed
- 10 Louver direction
- 11 Access to menu
- 12 Filter cleaning reminder

Outer dimensions (H×W×D)

120×120×16.5mm (thinnest part)
120×120×21.5mm (thickest part)

Capacity

Power Supply	Powered by indoor unit, 15VDC±10% 180g (approx.)
Installation	Indoor, on the wall or switch box
Connection capacity	Up to 16 indoor units (with the same wired remote controller)
▲ Display	When two wired Advanced Controller units are connected to the same indoor unit, the maximum brightness of each controller will be halved

* H is the height of the unit from the front, without the protrusion at the bottom.

System configuration example

Possibility of 2 Wired Controller Connection

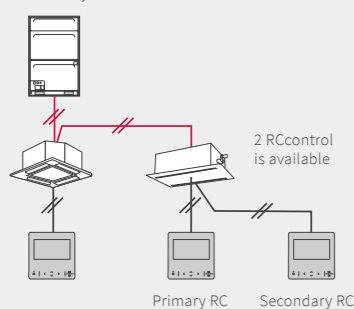

Up to 16 IDU connection

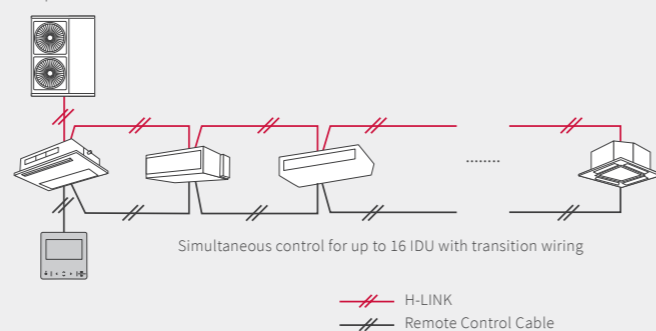

Energy optimization

Power-saving features enable VRF system operators to optimize energy usage

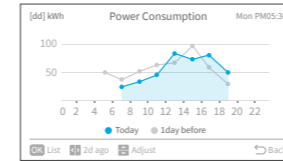

Energy consumption visualization

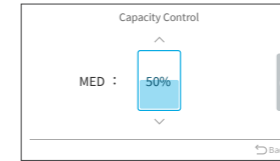

Capacity – peak cut control

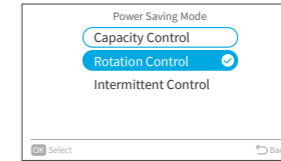

Choice of power-saving method

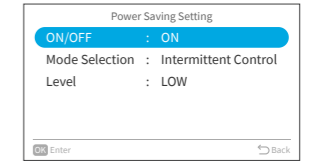

Power saving setting

Set specific schedules for features like peak capacity cuts and the thermal operation rotation of indoor units, enabling you to match energy-saving operation hours with your utility tariffs plan. Building managers can also set the minimum and maximum temperature range for occupants and visualize energy consumption with daily, weekly or monthly comparison options.

From basic to advanced functions

Users can control the main temperature settings from Advanced-Color controller's main screen. In addition, more advanced comfort settings help customizing the air to their occupants' specific needs.

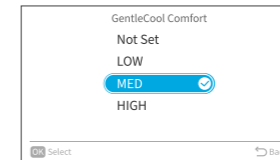

GentleCool limits the temperature of conditioned air, preventing cold drafts for optimal comfort.

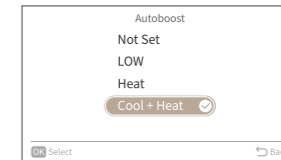

AutoBoost automatically activates for 30 minutes every time the AC is turned on, helping the room reach the desired temperature faster.

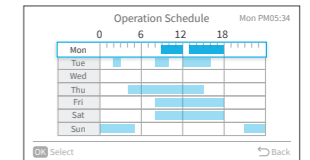

AC Scheduling is easier than ever, thanks to flexible features such as the holiday calendar.

The latest VRF features

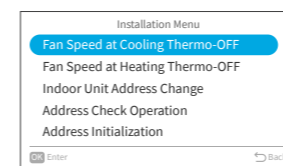

NEW Fan speed at thermo-off reduces air circulation when cooling or heating is not effective.

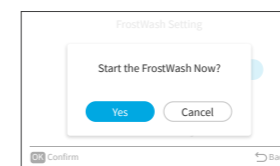

NEW Activate, schedule and check the history of indoor units' FrostWash™ function.

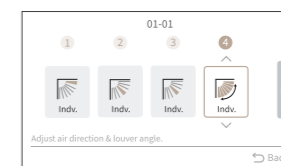

Individual **4-way cassette louvers** optimizes air flow direction to each corner layout.

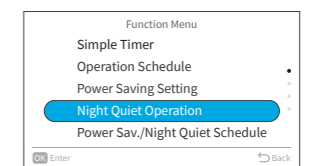

Schedule **Night Quiet** mode to minimize the outdoor unit's operation noise so you and your neighbors get a better night's sleep.

Special features for hotels

NEW Hotel mode enables instant access to the functions demanded most by hotel guests. After guests check out, housekeeping can reset the controller in one touch.

Hotel setback allows interlocking with hotel key cards. When the room is vacant, the indoor unit switches to a selected energy-saving setback temperature, ensuring the room remains at a comfortable temperature when unoccupied.

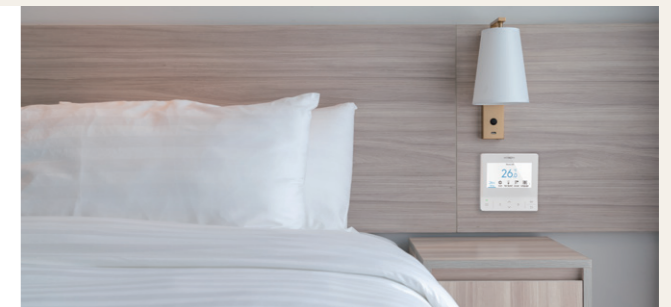

Ideal for indoor units with motion sensor features

NEW Active intelligent comfort features connected to your indoor unit's motion sensor and/or radiant sensor*: choice of direct/indirect air flow, FeetWarm NEW, FloorSense Cool NEW and the exclusive Crowd-Sense NEW to prevent heat peak from rapid crowd arrival.

INDIVIDUAL CONTROLLERS

NEW ECO-COMPACT CONTROLLER (PC-ARC-*)

Climate control in a compact size

- Great value for money that combines the best of form and function.
- Minimalist design aesthetic that reflects Hitachi's Duality Design philosophy.



- Budget-sensitive VRF projects
- Users who prefer simple controls
- Functional spaces

Stylish & Intuitive

With distinctive curves and an aesthetic inspired by Hitachi's Duality Design philosophy, the Eco-Compact Controller is stylish, ergonomic, cost-effective, and convenient. Enjoy climate control made easy through an optimized interface with easy-to-understand pictograms for a truly intuitive user experience.

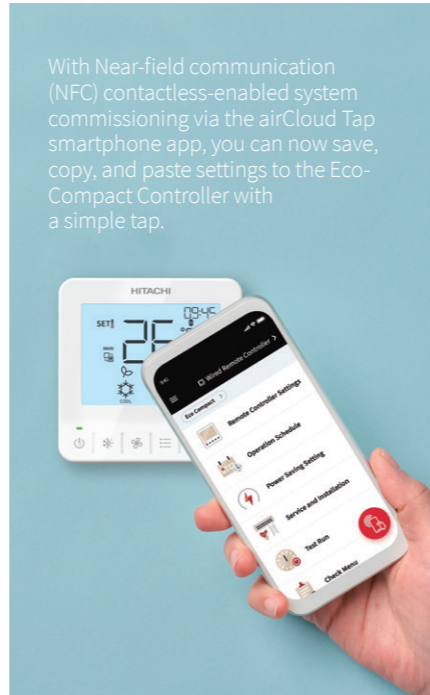

With Near-field communication (NFC) contactless-enabled system commissioning via the airCloud Tap smartphone app, you can now save, copy, and paste settings to the Eco-Compact Controller with a simple tap.



- 1 Set Temperature
- 2 Operation mode
- 3 Run indicator
- 4 On/Off button
- 5 Operation mode button
- 6 Fan speed button
- 7 Menu buttons
- 8 Directional key
- 9 Fan speed
- 10 Louver direction
- 11 Current time

Outer dimensions (H×W×D)

90mm×90mm×15.5mm(thinnest part)
90mm×90mm×18.5mm(thickest part)

Capacity

Power Supply	Powered by indoor unit, 15VDC±10% 100g (approx.)
Installation	Indoor, on the wall or switch box
Connection capacity	Up to 16 indoor units (with the same wired remote controller)

System configuration example

Possibility of 2 Wired Controller Connection

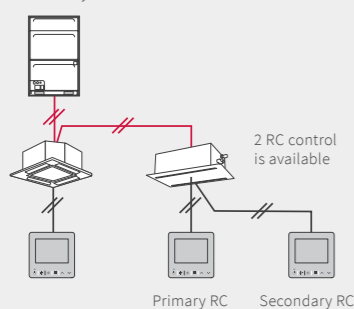

Up to 16 IDU connection

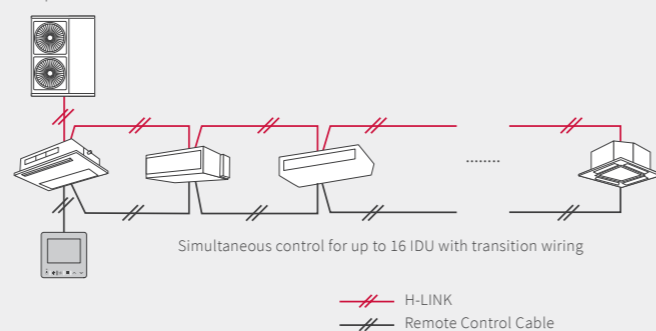

— H-LINK
— Remote Control Cable

Easy access to essential controls

Simplified navigation enables users to change temperatures and adjust essential controls directly from the home screen in one touch.



Set temperature with 0.5°C precision*

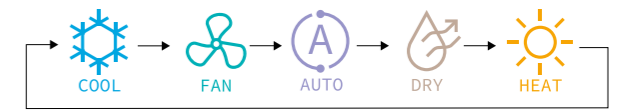

Operation modes

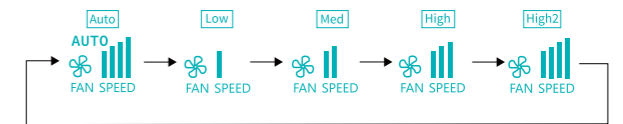

Fan speed



Louvers' positions

Energy-saving features

The Eco-Compact Controller includes energy-saving features to minimize unnecessary AC operation.



The **Peak-Cut** feature enables users to save even more energy during peak consumption periods.



Weekly scheduling automatically turns the indoor unit on/off at set times, great for classrooms, retail businesses or other premises with regular opening hours.

Accrued comfort

The Eco-Compact Controller includes energy-saving features to minimize unnecessary AC operation.



Include **GentleCool**, which controls the discharged air temperature for a smooth cooling down and prevents cold drafts.



AutoBoost activates for 30 minutes every time the AC is turned on, helping the room reach the desired temperature faster with a powerful automatic mode, which is ideal for meeting rooms and other areas requiring fast temperature reach.

Supports easy maintenance

A filter symbol appears when it's time to clean the filter. In the event of an error, the error code and the related indoor unit number is clearly displayed for ease of maintenance.

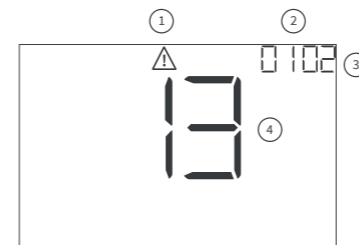

- 1 Alarm Icon
- 2 Indoor Unit No.(Refrigerant system)
- 3 Indoor Unit No.(Refrigerant system)
- 4 Alarm Code

Special features



For residential users: set the Sleep mode timer **NEW** to gradually change the room temperature for a better night's sleep. The unit will turn off automatically after a set time.



For hotels: interlock the Eco-Compact Controller with your hotel key card receiver and activate setback temperature while guest is away.

Embedded IR receiver

For use with the Wireless Remote Controller. Ideal for indoor units without embedded IR receiver (ex: ducted units)

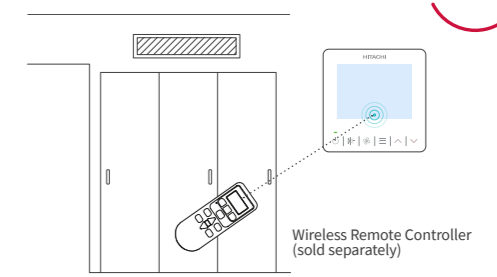

When IR receiver receives the commands, the buzzer sounds.
*Compatible HCRB10NEWQ and PC-LH7QE/PC-LH7QE1 wireless controllers

INDIVIDUAL CONTROLLERS

WIRED REMOTE CONTROLLER (HCWA10NEGQ)

Temperature display
Room temperature
RT 26.0°C RT 79.0°F

Set temperature
SET 26.0°C SET 79.0°F

ON/OFF button
Mode button

Liquid Crystal Display (LCD) screen

Up button & down button

Operation mode

- Cooling mode
- Heating mode
- Dry mode
- Fan mode
- Auto mode

Fan speed setting

Timer/Clock setting

Fan speed (flickering)

MAX

MIN

Timer setting

- ON Timer ON
- OFF Timer OFF
- ONCE Timer valid for one time
- DAILY Timer valid for one day
- WEEKLY Timer set for a week

Outer dimensions (H×W×D)
(mm) 88.0×88.0×15.5

Functions

Run/Stop
Operation Mode
Auto Mode Setting
Temperature Setting
Temperature Setting Rate 0.5°C/1.0°C/1.0°F
Fan Speed 3/4/6 taps
Louver Direction
Sensor Condition Check
Sensor Data Check
Alarm History Display
Test Run
Function Selection (Optional Function Setting)
Thermistor Selection
Thermistor Calibration
Input / Output Setting
Indoor Unit Address Change
key pad lock
Lower Limit for Cooling Operation
Upper Limit for Heating Operation
Simple Timer (On/Off)
Date/time setting
Filter Sign Reset
Side-by-side indoor unit identification
Temperature Unit °C/°F
Built-in Timer (On/Off)

Notes:
1. Fan speed taps setting unit availability varies with the indoor unit. Please check each technical catalog in advance.
2. Initial setting of temperature display is "Set temperature" display only. Please contact your dealer to display room temperature.

ADVANCED WIRELESS REMOTE CONTROLLER (PC-AWR)

Transmitter

Transmitting indication

LCD (Liquid Crystal Display)

Mode selection switch

Reset switch

Timer switches

Fan speed switch

On switch

Off switch

Louver angle switch

Temp. switch

Filter reset switch

Outer dimensions (H×W×D) (mm) 140.0×55.0×16.8

Functions

Run/Stop
Operation Mode
Auto Mode Setting
Temperature Setting
Temperature Setting Rate 0.5°C/1.0°C/1.0°F
Fan Speed 3/4/6 Taps
Louver Direction
Filter Sign Reset
Side-by-side indoor unit identification
Temperature Unit °C/°F
Built-in Timer (On/Off)

WIRELESS REMOTE CONTROLLER (PC-LH7QE)

Transmitter

Transmitting indication

LCD (Liquid Crystal Display)

Run/Stop switch

Temp. switch

Louver angle switch

Timer switches

Reset switch

Outer dimensions (H×W×D) (mm) 140.0×52.0×19.3

Functions

Run/Stop
Operation Mode
Auto Mode Setting
Temperature Setting
Temperature Setting Rate 1.0°C
Fan Speed 3/4/6 Taps
Louver Direction
Side-by-side indoor unit identification
Temperature Unit °C
Built-in Timer (On/Off)



RECEIVER KIT FOR WIRELESS REMOTE CONTROLLER

Model	PC-RLH11 (Basic)						PC-ALHZ1 (Advanced)				
	Ducted High ESP (AC Motor)	Ducted Medium ESP (AC Motor)	Ducted Low ESP (AC Motor)	Ducted Compact		Ducted Larger Air Volume (AC Motor)	Wall-Mounted (DC Motor)	Floor / Ceiling Convertible	Floor Concealed		
Indoor unit	RPI-HNAUNQ RPI-FSNQ	RPIM-HNAUNQ RPI-FSN3Q	RPIL-HNAUNQ	RPIZ-HNATNQ	RPIZ-HNDTSQ	RPI-FSN2SQ	RPK-HNBUSQ	RPFC-FSNQ	RPFI-FSNQ		
Advanced Wireless Remote Controller PC-AWR	○	○	○	○	○	○	○	○	○		
Standard Wireless Remote Controller PC-LH7QE	○	○	○	○	○	○	○	○	○		

Model	HR4A10NEWQ (Basic)	PC-ALH3 (Advanced)	PC-ALHC1 (Advanced)	P-AP56NAMR (Advanced)	PC-ALHD1 (Advanced)	PC-ALHS1 (Advanced)	PC-ALHP1 (Advanced)	PC-ALHZ1 (Advanced)				
	4-way Cassette	4-way Cassette	4-way compact Cassette	4-way compact Cassette	2-way Cassette	1-way Cassette	Ceiling Suspended	Wall-Mounted	Floor Exposed	Floor Concealed	Ducted High ESP	Ducted Medium ESP
Indoor unit	RCI-FSKDNQ	RCI-FSRP	RCIM-FSRE	RCIM-FSRE	RCD-FSR	RCS-FSR	RPC-FSR	RPK-FSRM RPK-FSRHM	RPF-FSN2E	RPFI-FSN2E	RPI-FSR RPI-FSN1	RPIM-FSR
Advanced Wireless Remote Controller PC-AWR	○	○	○	○	○	○	○	○	○	○	○	○
Standard Wireless Remote Controller PC-LH7QE	○	-	-	-	-	-	-	-	-	-	-	-

Basic Limited function available for centralized controllers
Temperature setting rate [1.0°C] only
Advanced Full function available for centralized controllers
Temperature setting rate [0.5°C/1.0°C/1.0°F]

(*) Basic function receiver kit is installed as a standard part in this wall-mounted unit. Wireless remote controller (PC-LH7QE) is delivered as a standard accessory as well. If separate placement of receiver kit is required, please use optional basic receiver kit (PC-RLH11) or optional advanced receiver kit (PC-ALHZ1).

Notes:
When using a basic receiver kit PC-RLH11 or HR4A10NEWQ together with wireless remote controller PC-LH7QE:
1) It won't be possible to lock individual remote controllers from Hitachi Central Stations (mini/EZ/EX)
2) It won't be possible to apply min/max restrictions on set temperature from Hitachi Central Stations (mini/EZ/EX)

ACCESSORIES



3P CONNECTOR CABLE (PCC-1A)

FOR CONNECTION TO REMOTE ON/OFF
DEVICE/RECEIPT OF OUTPUT SIGNAL

Operation example

•Cooling operation:

Compressor is ON by closing terminals 2 and 3 of CN3.
Compressor is OFF by opening terminals 2 and 3 of CN3.

•Heating operation:

Compressor is ON by closing terminals 1 and 2 of CN3.
Compressor is OFF by opening terminals 1 and 2 of CN3.

*One set contains five 3P connector cables.

*PCC-1A can connect to external signal input-output terminal both in outdoor unit and indoor unit.

System configuration example

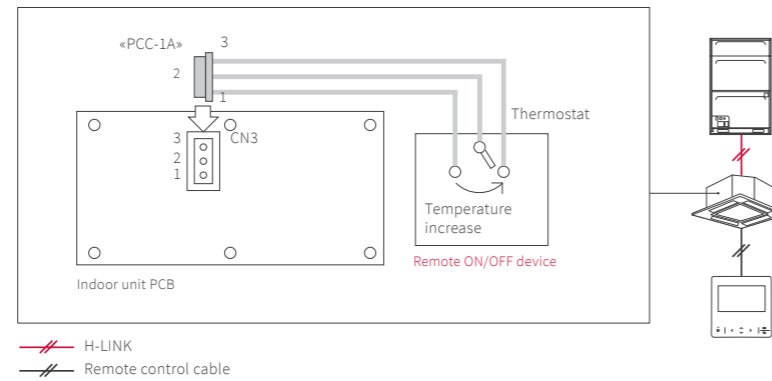

BMS ADAPTER FOR BACNET® (HC-A64BNP1)

CONTROL UP TO 64 INDOOR UNITS

Specifications

Outer dimensions (H×W×D)
(mm) 68.0×240.0×154.0

Functions

Corresponding BACnet® Standard	ANSI/ASHRAE Standard 135-2004 BACnet®
Control Item at Upper System	<ul style="list-style-type: none"> • Run Stop (Setting) • Operation Mode (Setting) • Fan Speed Level (Setting) • Indoor Temperature (Setting) • RC Operation lock (Setting) • Filter Sign Reset

Monitoring Item at Upper System

- Run Stop (State)
- Operation Mode (State)
- Fan Speed Level (State)
- Indoor Temperature (State)
- Prohibiting RC Operation (State)
- Filter Signal
- Indoor Air Intake Temperature
- Alarm Signal
- Alarm Code
- Communication State

System configuration example

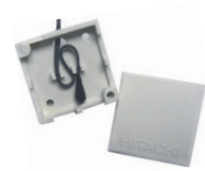
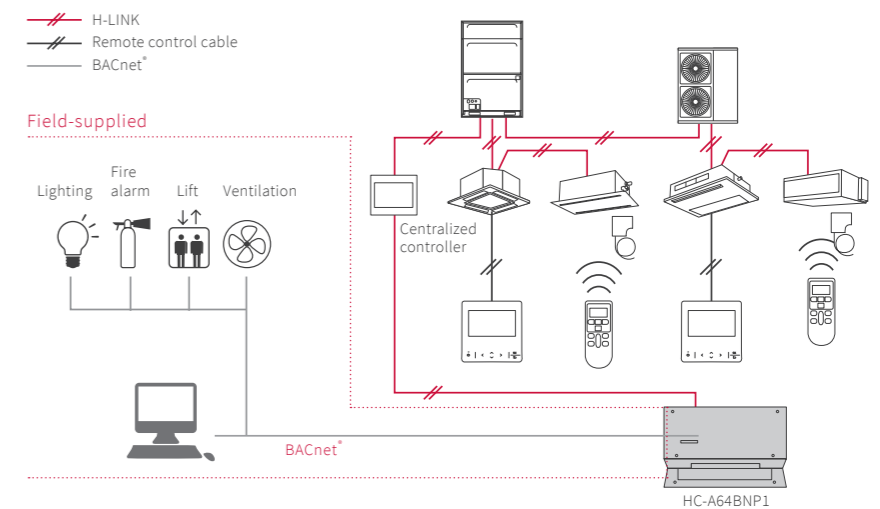

REMOTE SENSOR (THM-R2A) ROOM TEMPERATURE SENSOR

Outer dimensions (H×W×D)
(mm) 50.0×50.0×15.0

Length m 8.00

System configuration example

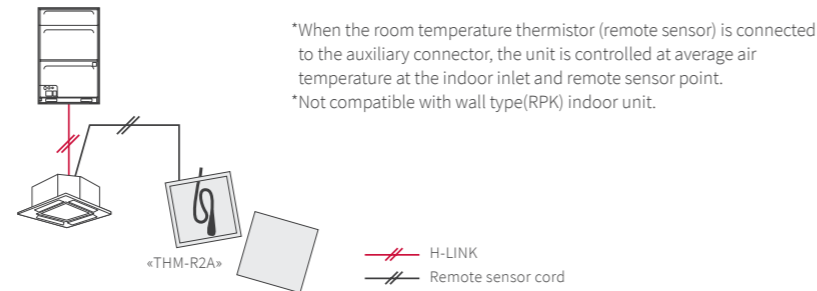

REMOTE CONTROL CABLE (PRC-5K, 10K, 15K) FOR PC-ARFG1 CONNECTION (TO IDU)

	PRC-5K	PRC-10K	PRC-15K
Length m	5.00	10.00	15.00

System configuration example

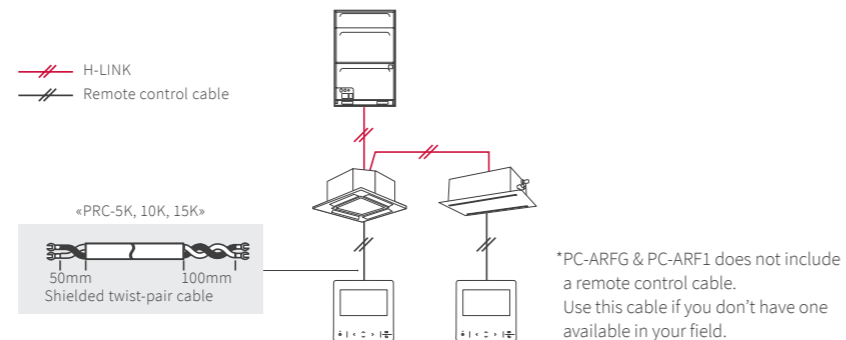

H-LINK: ENJOY MORE FREEDOM

WHAT IS H-LINK?

H-LINK is Hitachi Cooling & Heating original communication system to control multiple VRF refrigerant systems from one centralized control point.

H-LINK simplifies commissioning and service maintenance for installers and service engineers. For building owners and occupants, it provides outstanding versatility enabling the connection of various types of central control options, enabling better system management. Our proprietary high-performance communication system enables the connection of control wiring between indoor and outdoor units, and between a centralized control system and indoor/outdoor units across two or more refrigerant systems.

Examples



Educational institutions such as primary schools where installation work cannot be performed on weekdays.



Hotels where it is preferable to complete installation work during late evenings.



Rehabilitation facilities or hospitals where it is necessary to minimize the burden on users.



Definition of terms in Hitachi centralized control systems

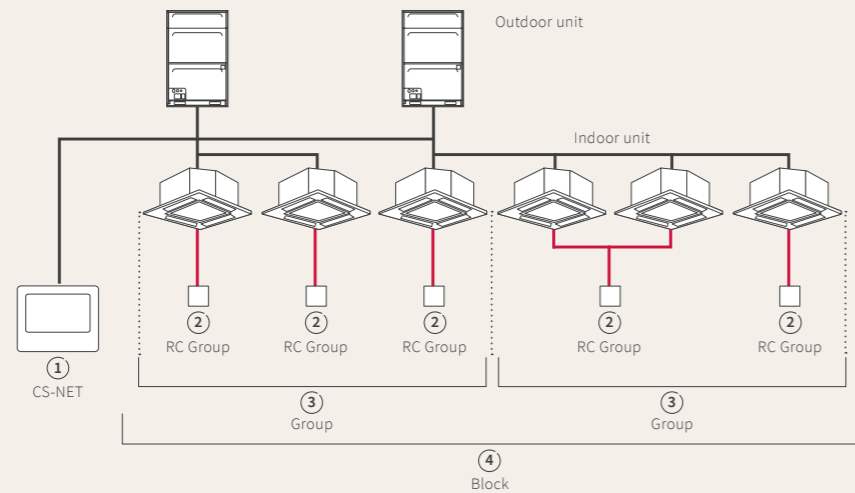

- ① CS-NET/Central station
→ Hitachi original centralized controller.
- ② RC Group (Remote Controller System Group)
→ Stands for a number of indoor units (up to 16 units) connected using "same remote controller" wiring. In this group, connected indoor units are all controlled in the same way.
- ③ Group
→ Stands for the multiple "RC groups" that are registered in the centralized controller network setting.
- ④ Block
→ Stands for the multiple "groups" that are registered in the centralized controller network setting.

CENTRALIZED CONTROLS: FLEXIBLE WIRING ROUTE!

- (1) • Multiple refrigerant systems located in one area.
 - Central monitoring room in separate area.

H-LINK SOLUTION

- Wire the central station to the closest indoor unit.
- Wiring distance is reduced substantially.

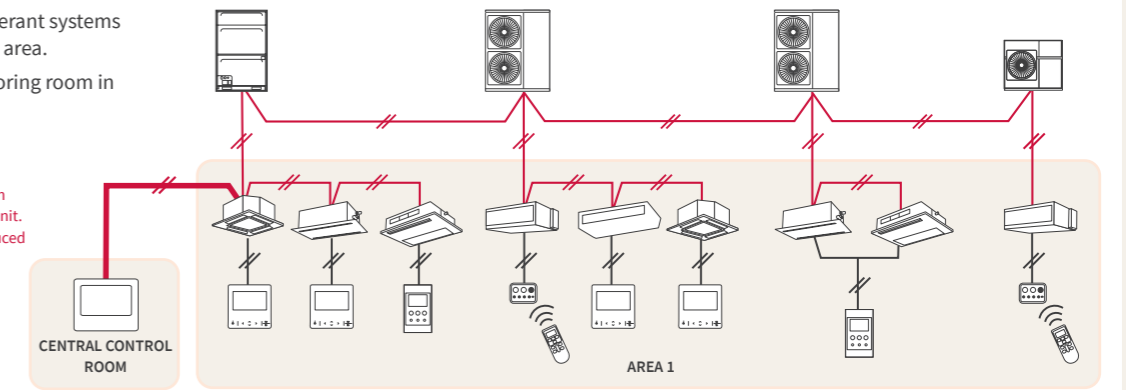

- (2) • Refrigeration systems in different places.
 - Some indoor units of each respective system are close to one another.

H-LINK SOLUTION

- Where two indoor units of each respective system are close together: you can connect two refrigerant systems via the indoor units.
- Wiring distance is reduced substantially.

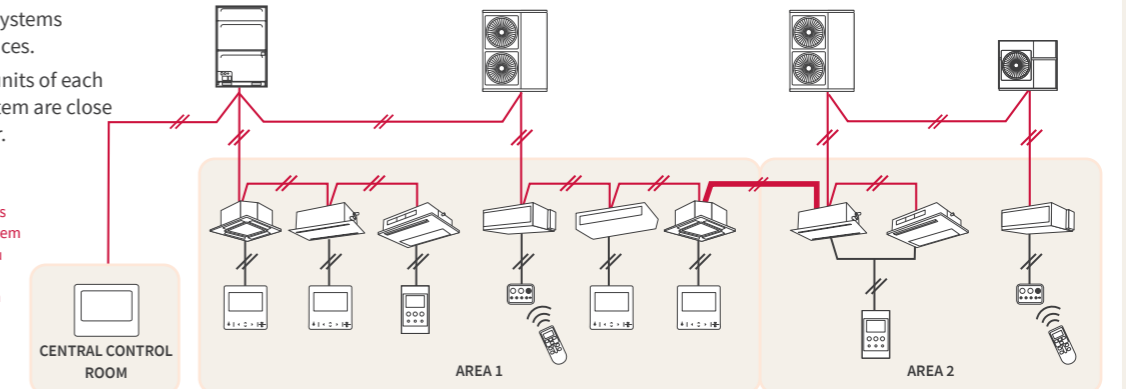

- (3) • One refrigerant system far away from the remaining ones.

H-LINK SOLUTION

- Connect the farthest refrigerant system directly to central station either to outdoor units or indoor units.
- The central station can make the central link between the different refrigerant systems.

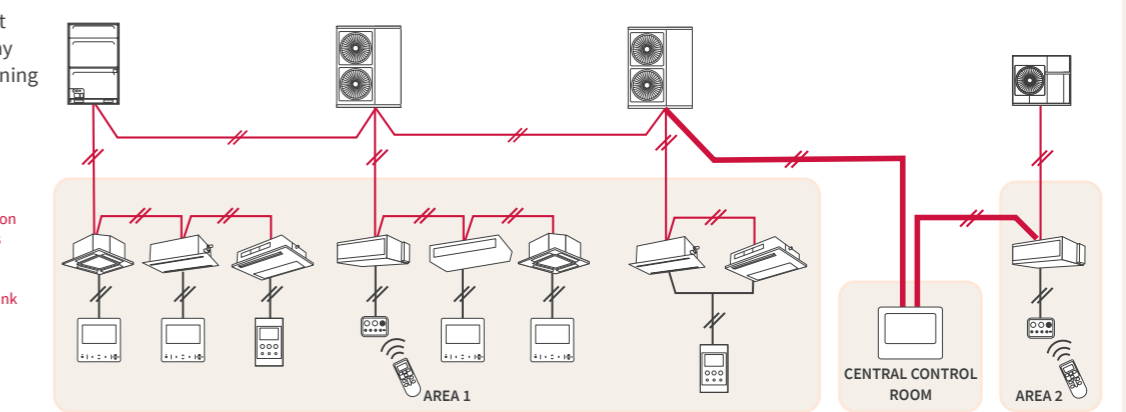

- (4) • Each refrigerant system in separate areas.
 - Indoor units are closer from one group to another.

H-LINK SOLUTION

- Centralized control can be achieved by connecting the refrigerant systems via the closer indoor units.
- Wiring can be indoors only.

